

Transportation Analysis

---

# APPENDIX L

---

---

# KIA OF CALABASAS CITY OF CALABASAS, CALIFORNIA

---

## REVISED TRANSPORTATION ANALYSIS

---

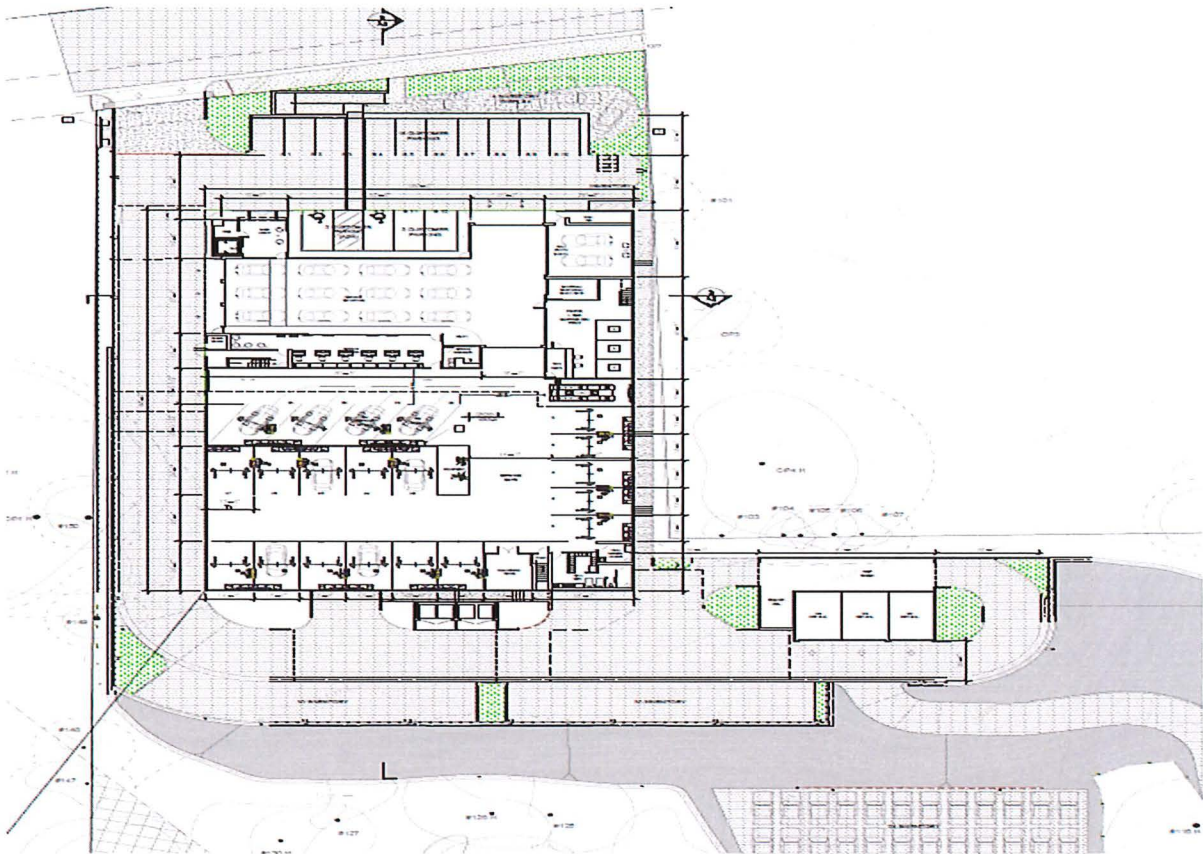

April 12, 2024

ATE Project #23066

---

### Prepared for:

Envicom Corporation  
4165 E. Thousand Oaks, Suite #290  
Westlake Village, CA 91362



## ASSOCIATED TRANSPORTATION ENGINEERS

100 N. Hope Avenue, Suite 4, Santa Barbara, CA 93110-1686 • (805) 687-4418 • FAX (805) 682-8509



# ASSOCIATED TRANSPORTATION ENGINEERS

100 N. Hope Avenue, Suite 4, Santa Barbara, CA 93110 • (805)687-4418 • FAX (805)682-8509 • [main@atesb.com](mailto:main@atesb.com)

Since 1978

Richard L. Pool, P.E.  
Scott A. Schell

April 12, 2024

23066R01

Travis Cullen  
Envicom Corporation  
4165 E. Thousand Oaks Boulevard, Suite #290  
Westlake Village, CA 91362

## ***REVISED TRANSPORTATION ANALYSIS FOR THE KIA OF CALABASAS - CITY OF CALABASAS***

Associated Transportation Engineers (ATE) has prepared the following revised transportation analysis for the Kia of Calabasas, proposed in the City of Calabasas. The revised transportation analysis address comments provided by City staff on the March 13<sup>th</sup> traffic analysis prepared by ATE. The revised traffic analysis evaluates the Project's consistency with the policies outlined in the City's Local Transportation Study Guidelines.

We appreciate the opportunity to assist you with this Project.

Associated Transportation Engineers

Scott A. Schell  
Principal Transportation Planner

CONTENTS

INTRODUCTION .....1

PROJECT DESCRIPTION .....1

TRAFFIC SCENARIOS AND SCOPE OF WORK .....1

EXISTING CONDITIONS .....4

    Street Network .....4

    Existing Intersection Operations.....5

PEDESTRIAN, BICYCLE AND TRANSIT FACILITIES .....8

CITY OF CALABASAS INTERSECTION ADVERSE EFFECT POLICY .....10

PLANNED IMPROVEMENTS.....11

EXISTING + PROJECT ANALYSIS .....11

    Project Trip Generation .....11

    Project Trip Distribution .....11

    Existing + Project Intersection Levels of Service.....13

CUMULATIVE ANALYSIS .....15

    Cumulative Traffic Forecasts .....15

    Cumulative Intersection Levels of Service .....17

    Cumulative + Project Intersection Levels of Service.....17

SITE ACCESS AND CIRCULATION .....19

    Sight Distance .....23

PARKING ANALYSIS .....26

    Zoning Ordinance Parking Requirements.....26

REFERENCES AND PERSONS CONTACTED .....27

TECHNICAL APPENDIX.....28

LIST OF TABLES

Table 1 - Existing Peak Hour Intersection Levels of Service .....	8
Table 2 - Project Trip Generation .....	11
Table 3 - Project Trip Distribution .....	13
Table 4 - Existing + Project AM Peak Hour Levels of Service.....	13
Table 5 - Existing + Project PM Peak Hour Levels of Service .....	13
Table 6 - Cumulative Projects Trip Generation.....	15
Table 7 - Cumulative Peak Hour Intersection Levels of Service.....	17
Table 8 - Cumulative + Project AM Peak Hour Level of Service .....	17
Table 9 - Cumulative + Project PM Peak Hour Level of Service.....	19
Table 10 - Zoning Ordinance Parking Requirements.....	26

LIST OF FIGURES

Figure 1 - Project Site Location .....	2
Figure 2 - Project Site Plan .....	3
Figure 3 - Existing Street Network.....	6
Figure 4 - Existing Traffic Volumes.....	7
Figure 5 - Project Trip Distribution and Assignment .....	12
Figure 6 - Existing + Project Traffic Volumes.....	14
Figure 7 - Cumulative Traffic Volumes.....	16
Figure 8 - Cumulative + Project Traffic Volumes .....	18
Figure 9 - Ingress Turning Movements .....	20
Figure 10 - Egress Turning Movements .....	21
Figure 11 - Project Frontage Improvement .....	22
Figure 12 - Project Driveway Corner Sight Distance.....	24
Figure 13 - Project Driveway Stopping Sight Distance.....	25

## INTRODUCTION

The following study contains an analysis of the potential traffic and circulation effects associated with the Kia of Calabasas (the "Project"), located in the City of Calabasas. The study provides information regarding existing and future traffic conditions within the Project study-area and recommends improvements where necessary. The transportation analysis follows the procedures outlined in the City of Calabasas Local Transportation Study Guidelines and evaluates the Project's consistency with the City policies.

## PROJECT DESCRIPTION



As illustrated on Figure 1, the Project site is located at 24460 Calabasas Road. The Project is proposing to construct a 47,944 square-foot new car sales dealership with a 2,117 square foot carwash on a site previously occupied by a retail nursery. The Project site plan is illustrated on Figure 2. As shown, site access will be provided via a driveway connection to Calabasas Road. A total of 79 parking spaces and 4 bicycle spaces will be provided on-site.

## TRAFFIC SCENARIOS AND SCOPE OF WORK

The traffic study assesses potential traffic effects for the following scenarios.

### Traffic Scenarios

- 1) Existing Conditions
- 2) Existing + Project Conditions
- 3) Cumulative (Existing+ Approved/Pending Projects) Conditions
- 3) Cumulative (Existing+ Approved/Pending Projects) + Project Conditions

The traffic analysis evaluates the weekday AM and PM peak hour periods for 3 study-area intersections. The Cumulative scenario provides an analysis of the development of approved/pending projects. The Cumulative + Project assumes development of approved/pending projects and the Project.

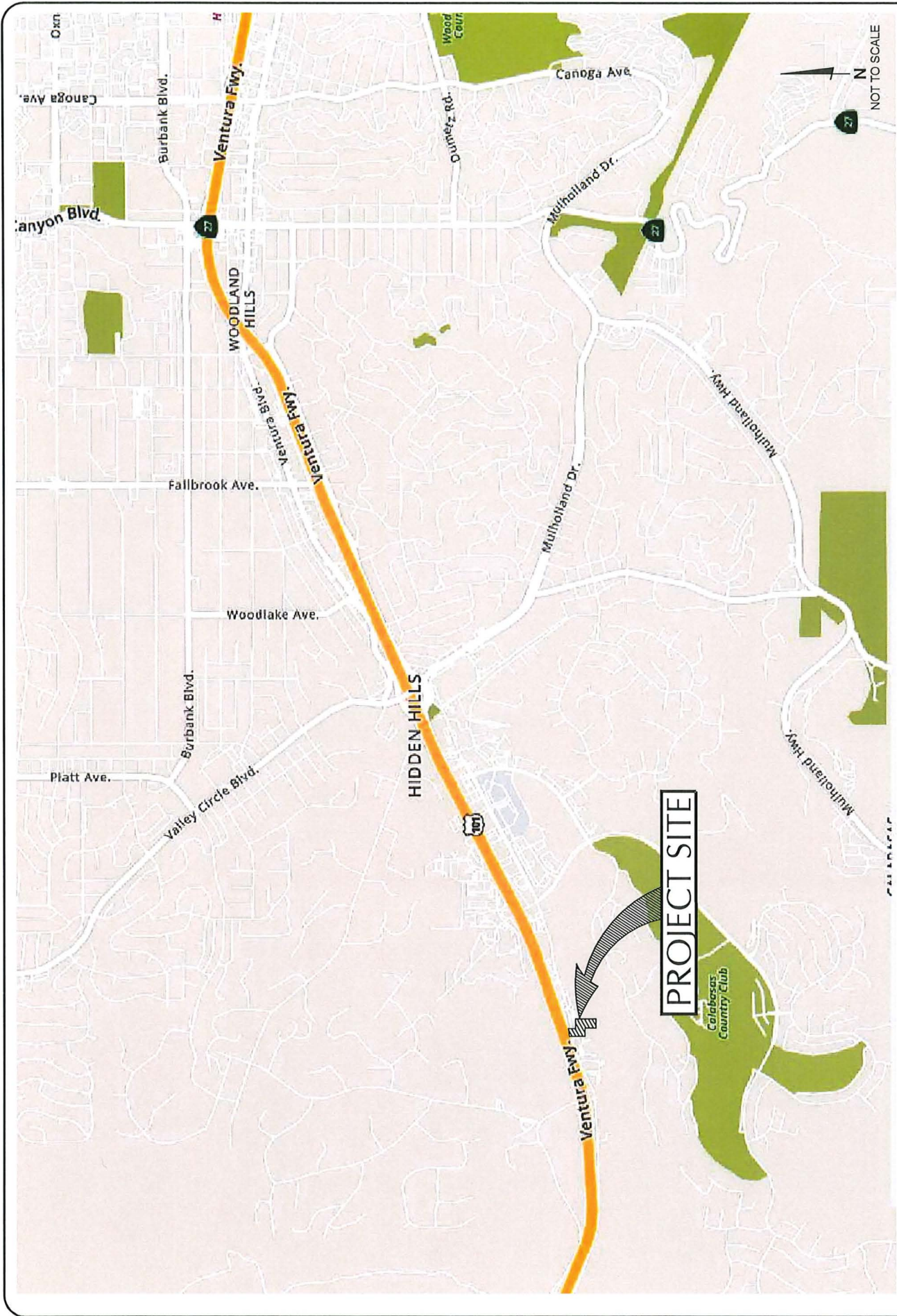

FIGURE 1

PROJECT SITE LOCATION

GM-ATE#23066

ASSOCIATED  
TRANSPORTATION  
ENGINEERS



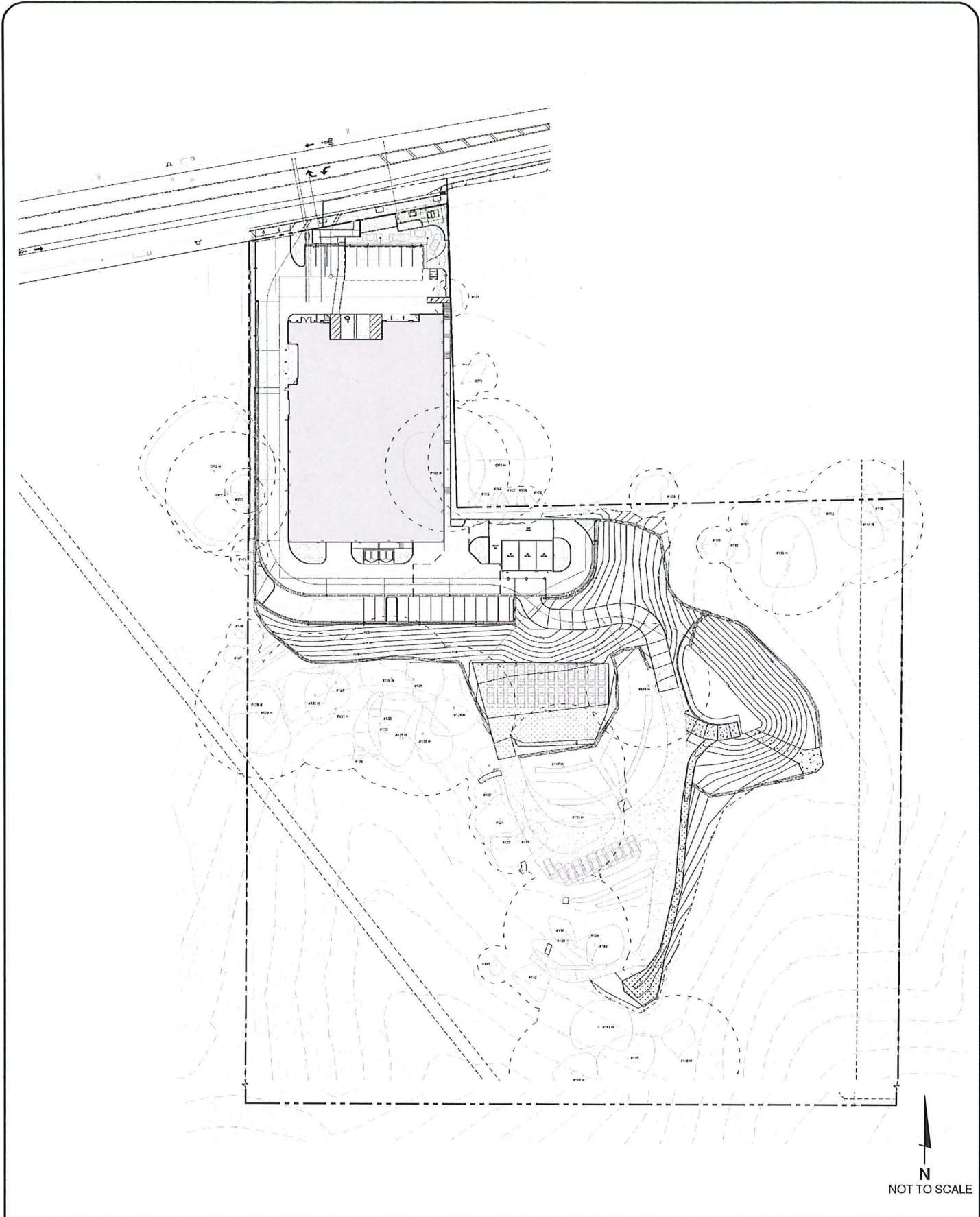

ASSOCIATED  
TRANSPORTATION  
ENGINEERS

PROJECT SITE PLAN

FIGURE 2

GM- ATE#23066

The scope of work and traffic assessment methodologies presented in this study were developed based on the requirements outlined in the City of Calabasas Local Transportation Study Guidelines.

## EXISTING CONDITIONS

### Street Network

The Project site is served by a network of arterial roads and collector streets as illustrated in Figure 1. The following text provides a brief description of the major components of the study-area street network.

**Calabasas Road**, located adjacent to the Project site, is an east-west 2 to 4-lane undivided arterial roadway in the study-area. The posted speed on Calabasas Road is 40 mph. The roadway extends east from Mureau Road to Mulholland Drive and serves primarily commercial uses in the study-area. The roadway is partially improved with curb, gutter and sidewalks from Mureau Road to Parkway Calabasas. No sidewalk is currently provided adjacent to the Project site. The existing on-street parking is used by the adjacent auto dealerships. Class II bike lanes are provided along the roadway. The Project will improve Calabasas Road along its frontage. The intersections of Calabasas Road/Calabasas Parkway and U.S. Highway 101 southbound ramps/Calabasas Road are controlled by traffic signals.

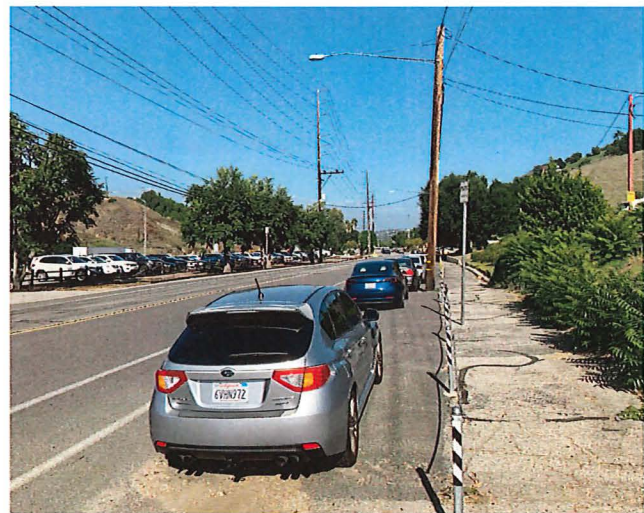

**Parkway Calabasas**, located east of the Project site, is a north-south 2 to 4-lane divided arterial roadway in the study-area. The posted speed on Parkway Calabasas is 40 mph. The roadway extends south from the Hidden Hills West Estates gated community to the Estates at the Oaks gated community. Parkway Calabasas serves primarily residential and commercial uses in the study-area. The roadway is fully improved with curb, gutter and sidewalk.

Class II bike lanes are provided along the roadway. The intersection of Calabasas Road/Parkway Calabasas is controlled by traffic signals.

**Mureau Road**, located west of the Project site, is an east-west 2 to 4-lane arterial roadway in the study-area. The posted speed on Mureau Road is 35 mph. The roadway extends east from Las Virgenes Road to Calabasas Road. Mureau Road serves primarily residential uses in the study-area. The roadway is partially improved with curb and gutter. Class II bike lanes are provided along the roadway. Currently the intersection of Calabasas Road/Mureau Road is STOP-Sign controlled. A roundabout is programmed for installation at the Calabasas Road/Mureau Road intersection in 2024/2025 and is assumed to be in place for the post Project scenarios.



### Existing Intersection Operations

Because traffic flow on urban arterial roadways is most constrained at intersections, detailed traffic flow analyses focus on the operating conditions of critical intersections during peak travel periods. "Levels of Service" (LOS) A through F are used to rate intersection operations, with LOS A indicating free flow operations and LOS F indicating congested operations (more complete definitions of levels of service are included in the Technical Appendix). The City of Calabasas considers LOS C better acceptable for signalized City intersections and LOS D for freeway ramp intersections.

Figure 3 shows the existing traffic controls and lane geometries at the study-area intersections and Figure 4 illustrates the existing AM and PM peak hour traffic volumes. Existing intersection traffic volumes were obtained from traffic count data collected on February 1, 2023 (see Technical Appendix for count data). Counts provided by the City of Calabasas were conducted during the AM peak commuter period (7:00-9:00 AM) and PM peak commuter period (4:00-6:00 PM). The peak 1-hour volumes were then identified for the analysis.

Levels of service were calculated for the signalized and unsignalized study-area intersections using the methodology outlined in the Highway Capacity Manual (HCM 6<sup>th</sup> Edition). Levels of service are based on the average number of seconds of delay per vehicle during the peak 15-minute period within the overall peak hour. Table 1 lists the Existing traffic controls and levels of service for the study-area intersections (calculation worksheets included in Technical Appendix).

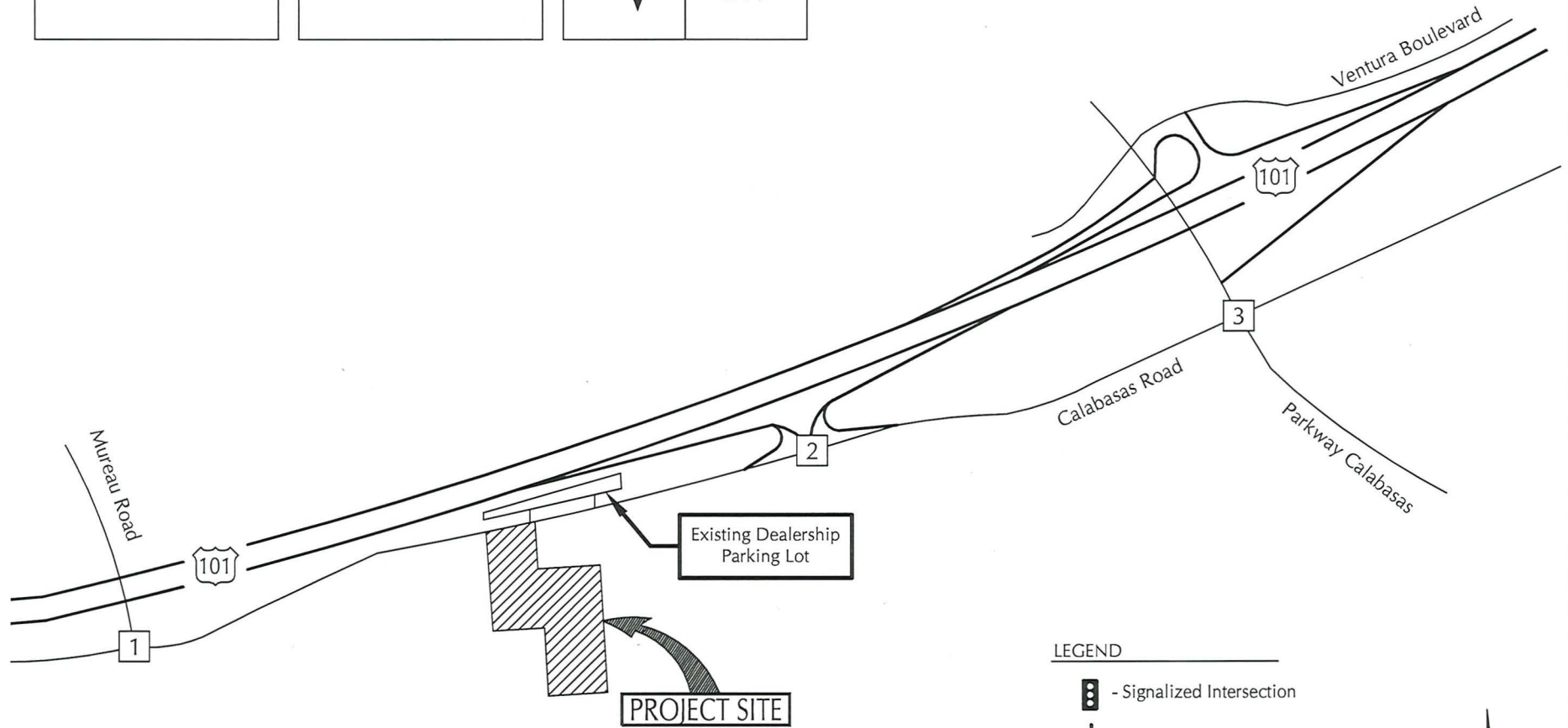
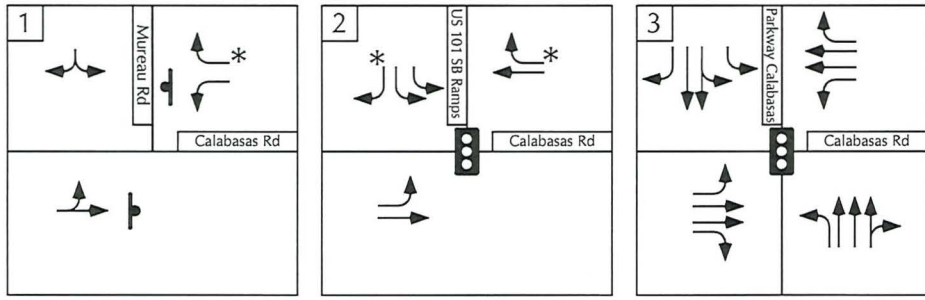

LEGEND

- Signalized Intersection
- Stopped Approach
- Lane Geometry
- Free Right-Turn Lane



ASSOCIATED  
TRANSPORTATION  
ENGINEERS

EXISTING STREET NETWORK

FIGURE 3

GM- ATE#23066

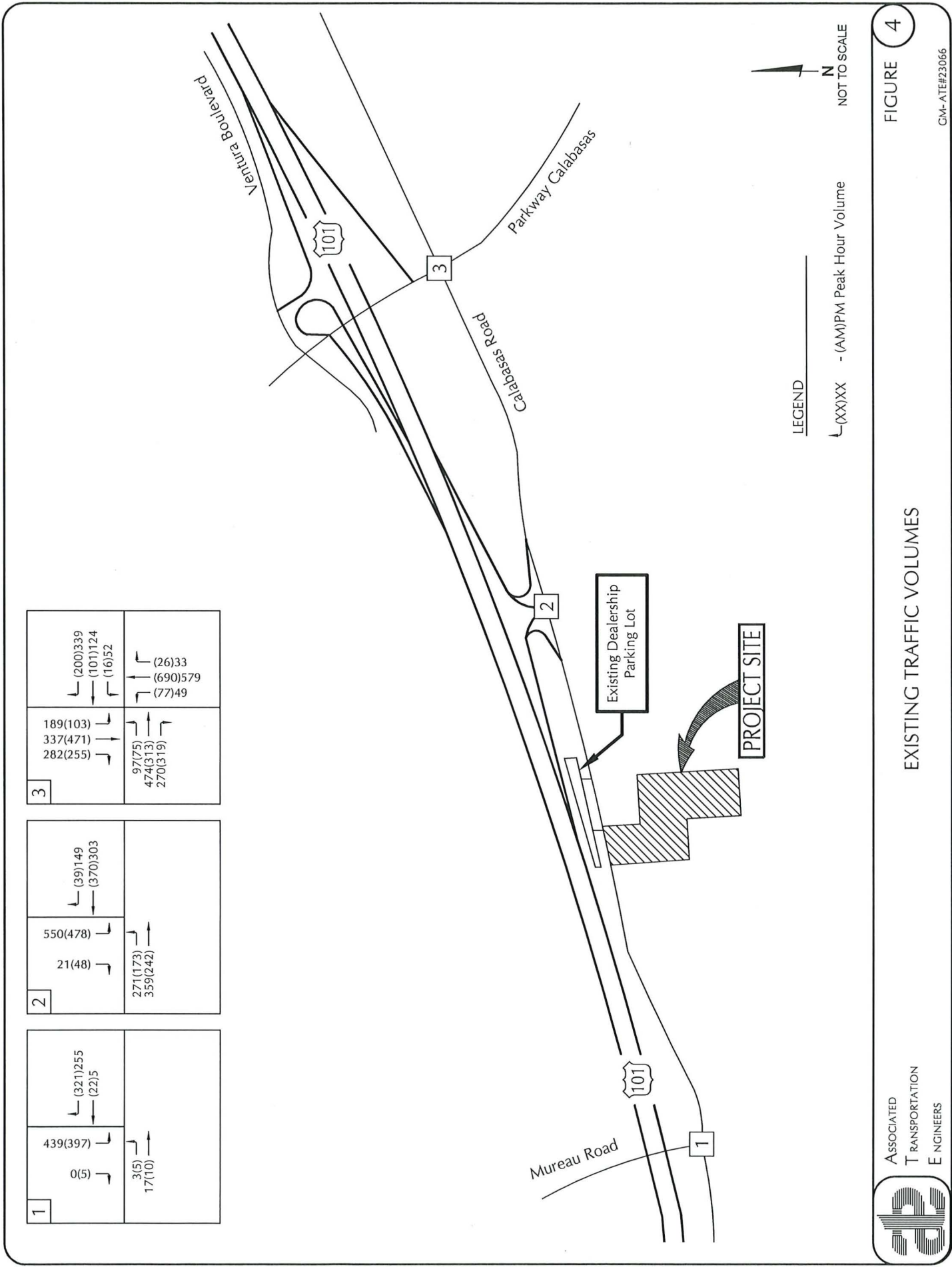

<b>1</b>	<p>439(397) ←</p> <p>0(5) ↓</p> <p>3(5) ↑</p> <p>17(10) →</p>	<p>← (32)1255</p> <p>→ (22)15</p>	<p>← (200)339</p> <p>← (101)124</p> <p>← (16)52</p> <p>↑ (26)33</p> <p>↑ (690)579</p> <p>↑ (77)49</p>
<b>2</b>	<p>550(478) ←</p> <p>21(48) ↓</p> <p>271(173) ↑</p> <p>359(242) →</p>	<p>← (39)149</p> <p>→ (370)303</p>	<p>97(75) ↓</p> <p>474(313) ↑</p> <p>270(319) →</p>
<b>3</b>	<p>189(103) ←</p> <p>337(471) ↓</p> <p>282(255) →</p>		

FIGURE 4

EXISTING TRAFFIC VOLUMES



ASSOCIATED  
TRANSPORTATION  
ENGINEERS

LEGEND

←(XX)XX - (AM)PM Peak Hour Volume



NOT TO SCALE

**Table 1  
Existing Peak Hour Intersection Levels of Service**

Intersection	Control	Delay/LOS(a)	
		AM Peak Hour	PM Peak Hour
Calabasas Road/Mureau Road	STOP-Sign	22.8 Sec./LOS C	20.5 Sec./LOS C
U.S. Highway 101 SB Ramps/Calabasas Road	Signal	22.9 Sec./LOS C	21.9 Sec./LOS C
Calabasas Road/Calabasas Parkway	Signal	35.6 Sec./LOS D	33.8 Sec./LOS D

The data presented in Table 1 show that the study-area intersections operate in the LOS C - D range during the AM and PM peak hour periods.

**PEDESTRIAN, BICYCLE AND TRANSIT FACILITIES**

Pedestrian and Bicycle Facilities



Currently there are limited pedestrian facilities (sidewalks, crosswalk, etc.) located along Calabasas Road in the study-area. Sidewalks are provided along the developed portions of Calabasas Road in the study-area. Currently there is no sidewalk provided on Calabasas Road adjacent to the Project site. As part of the Project frontage improvements, a sidewalk will be provided on Calabasas Road. The Project site design includes an internal pedestrian pathway that will

connect to the sidewalk along Calabasas Road. The sidewalks connect the Project to the local transit service provided in the study-area on Parkway Calabasas. The nearest pedestrian crosswalk across Calabasas Road is provided at the signalized Calabasas Road/Parkway Calabasas intersection. Striped pedestrian crosswalks, ADA ramps with detectable warning strips and pedestrian call buttons are provided on each leg of the intersection. The proposed Project would not have an adverse effect on the existing pedestrian facilities.

The Project site is served by the City of Calabasas Bikeway System. The existing bicycle facilities located in the study-area consist of Class II bike lanes along Calabasas Road, Parkway Calabasas and Mureau Road. These bike facilities connect the Project to the residential areas east and west of the Project. The proposed Project would not have an adverse effect on the existing bicycle facilities. Bicycle parking (4 spaces) would be provided on-site for employees and customers that choose to bike to the Kia of Calabasas.

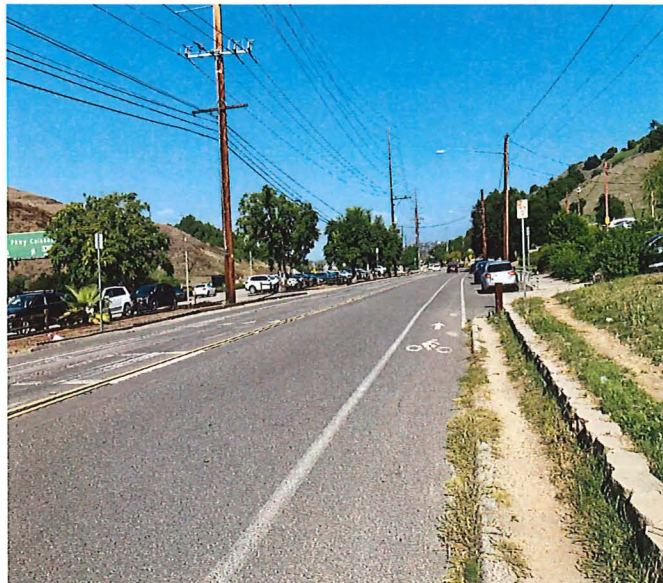

### Transit Facilities



The City of Calabasas, Los Angeles Metro (Metro) and Los Angeles Department of Transportation (LADOT) are the local transit providers in the City of Calabasas. The Project site is served by the City of Calabasas Line 1 Shuttle. The Line 1 Shuttle operates Monday through Friday from 6:30 AM to 6:00 PM providing fixed route bus service on Calabasas Road in the vicinity of the Project site. The nearest Line 1 Shuttle stop to the Project is located just west of the site adjacent to Bob Smith's BMW dealership.

The Project site is also served by the LA Metro #161 Route (Canoga Station - Thousand Oaks). The #161 Route operates daily providing fixed route bus service on Parkway Calabasas in the vicinity of the Project site. During the peak commute hours, the #161 Route operates with 30-minute headways. The nearest Route #161 stop to the Project is located on the west side of Parkway Calabasas, just south of Calabasas Road. The Project site is also served by the LADOT Commuter Express #423 Route (Downtown LA - Thousand Oaks). The #423 Route operates Monday through Friday providing fixed route bus service on Calabasas Road and Parkway Calabasas in the vicinity of the Project site. During the peak commute hours, the



#423 Route operates with 30-minute headways. The nearest #423 Route stop to the Project is located on the west side of Parkway Calabasas, just south of Calabasas Road. The proposed Project has the potential to increase transit ridership in the study-area which would be accommodated by the existing transit service provided.

### CITY OF CALABASAS INTERSECTION ADVERSE EFFECT POLICY

An adverse effect on intersection operations occurs when the analysis demonstrates that a project would cause the operations standard at a study intersection to fall below LOS C with the addition of project vehicle-trips to baseline conditions. For signalized intersections already operating at LOS D, E or F under baseline conditions, an adverse effect is defined in the following tables.

#### City of Calabasas Criteria for City-Operated Signalized Intersections

LOS without Project	LOS with Project	Average Total Delay (Seconds per Vehicle)	Project-Related Increase in Seconds of Average Total Delay
A, B or C	D, E or F	-	Any increase in delay
D, E or F	D, E or F	> 35.0	Equal to or greater than 5.0 seconds

#### City of Calabasas Criteria for Signalized Freeway Intersections

LOS without Project	LOS with Project	Average Total Delay (Seconds per Vehicle)	Project-Related Increase in Seconds of Average Total Delay
A, B, C or D	E or F	-	Any increase in delay
E or F	E or F	> 55.0	Equal to or greater than 5.0 seconds

#### City of Calabasas Criteria for Unsignalized (All-Way STOP Controlled) Intersections

LOS without Project	LOS with Project	Average Total Delay (Seconds per Vehicle)	Project-Related Increase in Seconds of Average Total Delay
A, B or C	D, E or F	-	Any increase in delay
D, E or F	D, E or F	> 25.0	Equal to or greater than 3.0 seconds

#### City of Calabasas Criteria for Unsignalized (Two-Way STOP Controlled) Intersections

LOS with Project	Average Total Delay (Seconds per Vehicle)	Project-Related Increase in LOS or Seconds of Average Total Delay
D	> 25.0 to 35.0	LOS C or better to LOS D or worse and meets the peak hour warrant for a traffic signal
E	> 35.0 to 50.0	LOS D or better to LOS E or worse and meets the peak hour warrant for a traffic signal
F	> 50.0	> 10 seconds of delay for worst-case approach if already at LOS F and meets the peak hour warrant for a traffic signal

An adverse intersection operation effect by City of Calabasas standards may be addressed by implementing measures that would restore intersection level of service to background conditions or better.

**PLANNED IMPROVEMENTS**

Calabasas Road/Mureau Road. The intersection is currently STOP-Sign controlled on the eastbound approach. The City has programmed the implementation of a three-approach single lane roundabout with YIELD traffic control at the intersection in 2024/2025. The Existing + Project and Cumulative analysis therefore evaluates the future intersection operations assuming the roundabout control.

**EXISTING + PROJECT ANALYSIS**

Project Trip Generation

The Project is proposing to construct 47,944 square-feet of new auto sales space. Trip generation estimates were calculated for the Kia of Calabasas Project based on the rates published in the Institute of Transportation Engineers (ITE), Trip Generation, 11<sup>th</sup> Edition for Automobile Sales - New (Land Use Code #840). The analysis assumes that the car wash facility would be an ancillary use to the dealership and would not generate any additional traffic. Table 2 presents the trip generation estimates for the Project.

**Table 2  
Project Trip Generation**

Land Use	Size	ADT		AM Peak Hour		PM Peak Hour	
		Rate	Trips	Rate	Trips	Rate	Trips
Automobile Sales - New	47,944 SF	27.84	1,335	1.86	89 (65/24)	2.42	116 (46/70)

The data presented in Table 2 indicate that the Kia of Calabasas Project is estimated to generate 1,335 ADT, 89 AM peak hour trips and 116 PM peak hour trips.

Project Trip Distribution

The trip distribution model developed for the Project was based on existing traffic patterns observed in the study-area, estimated service area for the new car dealership, the proposed site access and parking system, and input from City staff. Table 3 presents the trip distribution percentages developed for the analysis and Figure 5 illustrates the assignment of Project traffic on the study-area street network.

1	5(6)	(2)7
2	18(27)	(32)23
3	18(26)	(3)3
	32(10) 4(2) 3(2)	(3)2
	24(8) 39(14)	

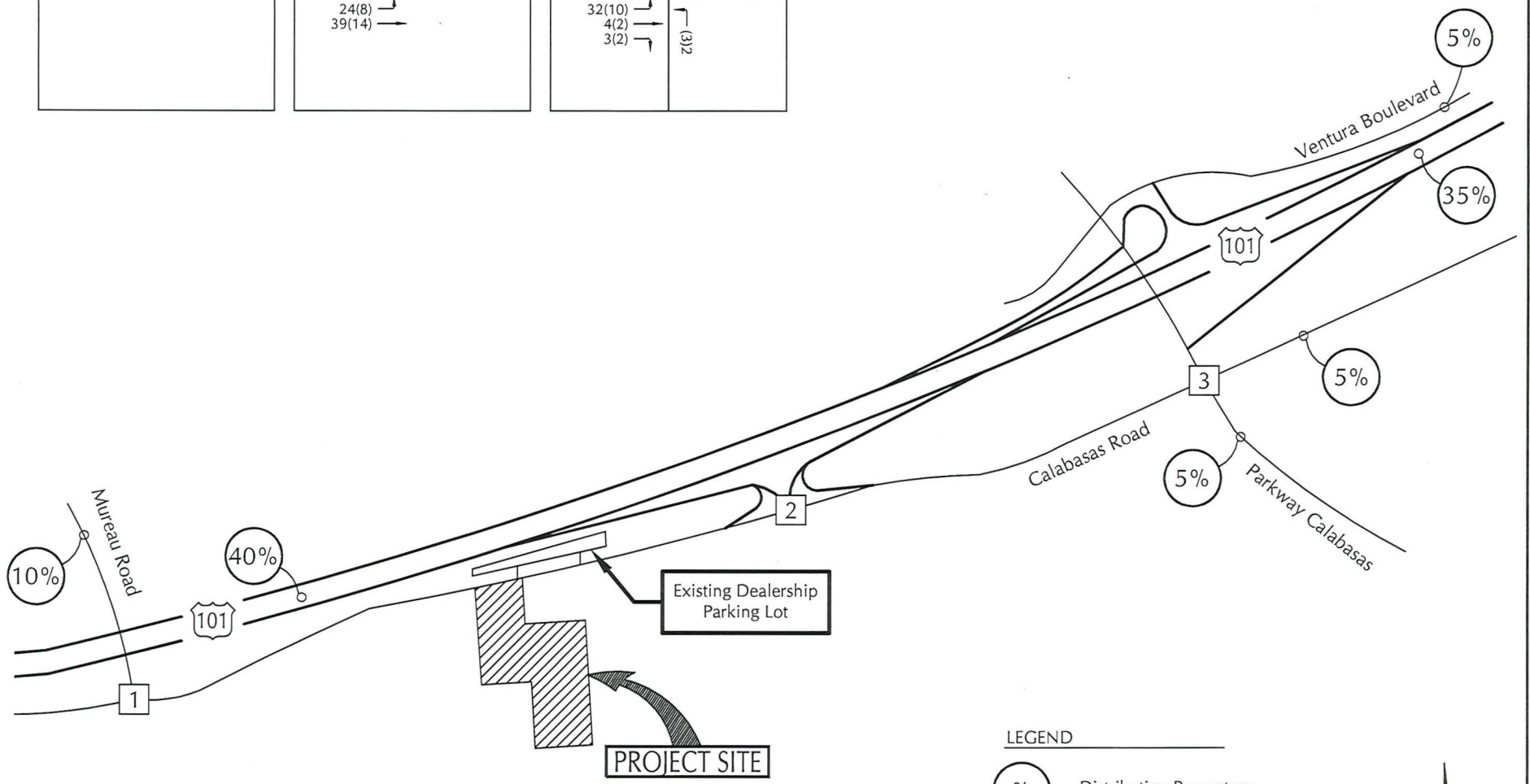

LEGEND

- % - Distribution Percentage
- (XX)XX - (AM)PM Peak Hour Volume

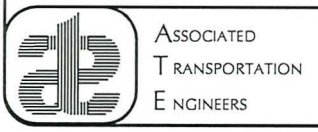

PROJECT TRIP DISTRIBUTION AND ASSIGNMENT

FIGURE 5

GM- ATE#23066

**Table 3  
Project Trip Distribution**

Route	Origin/Destination	Percentage
U.S. Highway 101	North	40%
	South	35%
Calabasas Parkway	South	5%
Calabasas Road	East	5%
Ventura Boulevard	East	5%
Mureau Road	West	10%
<b>Total:</b>		<b>100%</b>

Existing + Project Intersection Levels of Service

Levels of service were calculated for the study-area intersections assuming the Existing + Project traffic volumes illustrated on Figure 6. Tables 4 and 5 compare the Existing and Existing + Project AM and PM peak hour levels of service for the study-area intersections and identify operational effects based on City policy. The City has programmed the implementation of a three-approach single lane roundabout with YIELD traffic control at the Calabasas Road/Mureau Road intersection in 2024/2025. The Existing + Project analysis evaluates the intersection operations assuming roundabout control.

**Table 4  
Existing + Project AM Peak Hour Levels of Service**

Intersection	Existing		Existing + Project		Project-Added	
	Delay	LOS	Delay	LOS	Delay	Exceed?
Calabasas Road/Mureau Road	22.8 Sec.	LOS C	3.8 Sec.	LOS A	0.0 Sec.	NO
U.S. Highway 101 SB Ramps/Calabasas Road	22.9 Sec.	LOS C	23.2 Sec.	LOS C	0.3 Sec.	NO
Calabasas Road/Calabasas Parkway	35.6 Sec.	LOS D	35.9 Sec.	LOS D	0.3 Sec.	NO

**Table 5  
Existing + Project PM Peak Hour Levels of Service**

Intersection	Existing		Existing + Project		Project-Added	
	Delay	LOS	Delay	LOS	Delay	Exceed?
Calabasas Road/Mureau Road	20.5 Sec.	LOS C	3.9 Sec.	LOS A	0.0 Sec.	NO
U.S. Highway 101 SB Ramps/Calabasas Road	21.9 Sec.	LOS C	22.0 Sec.	LOS C	0.1 Sec.	NO
Calabasas Road/Calabasas Parkway	33.8 Sec.	LOS C	33.9 Sec.	LOS C	0.1 Sec.	NO

<p><b>1</b></p> <p>444(403) 0(5)</p> <p>(323)262 (22)5</p> <p>3(5) 17(10)</p>	<p><b>2</b></p> <p>550(478) 39(75)</p> <p>(39)149 (402)326</p> <p>295(181) 398(256)</p>	<p><b>3</b></p> <p>189(103) 337(471) 300(281)</p> <p>(200)339 (104)127 (16)52</p> <p>129(85) 478(315) 273(321)</p> <p>(26)33 (690)579 (80)51</p>
---	---	--

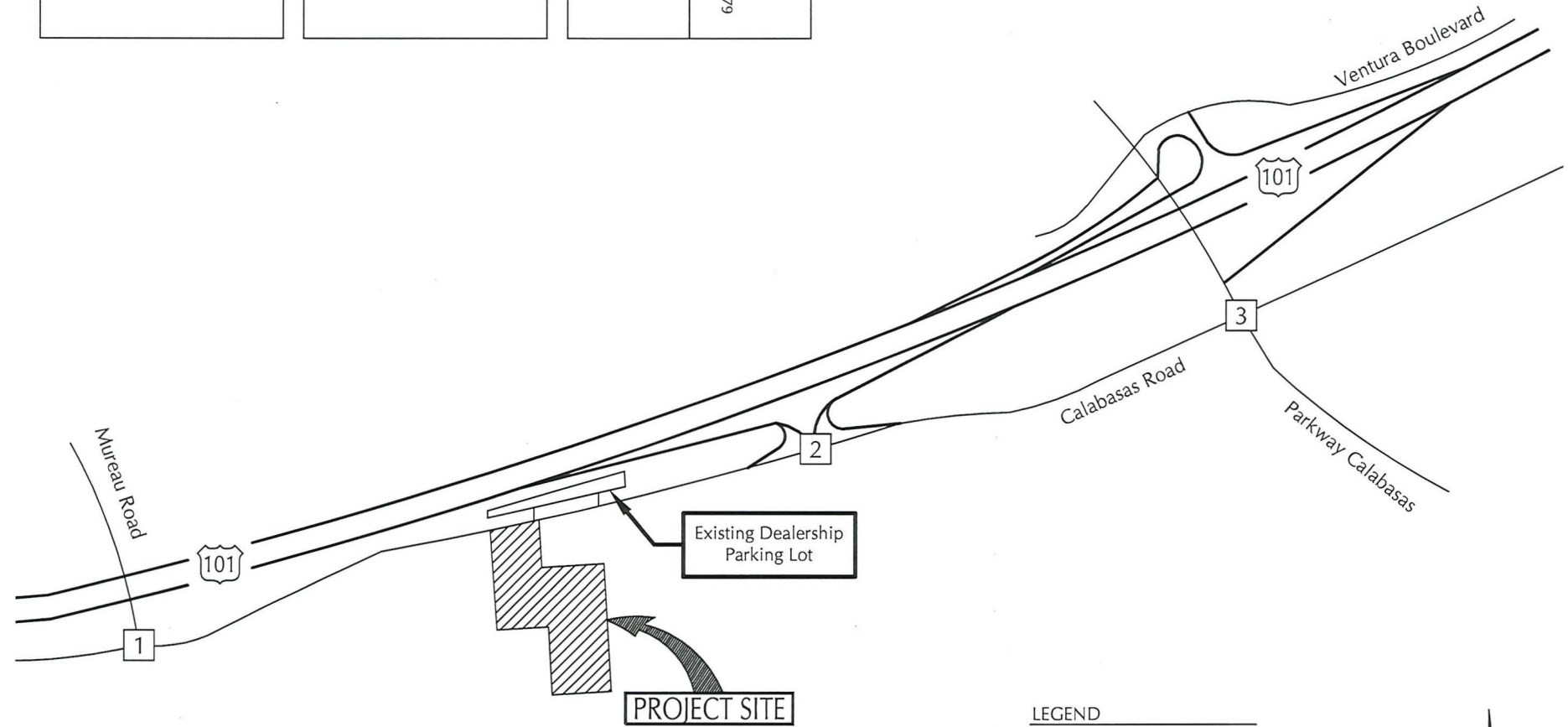

LEGEND

- ↳(XX)XX - (AM)PM Peak Hour Volume
- - Roundabout

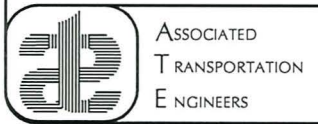

EXISTING + PROJECT TRAFFIC VOLUMES

FIGURE 6

GM- ATE#23066

The data presented in Tables 4 and 5 indicate that with the addition of Project traffic the study-area intersections would operate in the LOS A - D range during the AM and PM peak hour periods. For City operated signalized intersections already operating at LOS D, E or F under baseline conditions, an adverse effect is defined as an increase of 5 seconds or more. The Project would not have an adverse effect on intersection operations based on the City's intersection operation policy.

**CUMULATIVE ANALYSIS**

The City of Calabasas Local Transportation Study Guidelines require that intersection operations be evaluated assuming development of approved/pending projects proposed within the City of Calabasas.

Cumulative Traffic Forecasts

Cumulative traffic volumes were forecast for the study-area intersections assuming development of the approved and pending projects proposed within the City of Calabasas. The list of projects was obtained from the City of Calabasas. Trip generation estimates were calculated for the cumulative projects based on the rates published in the Institute of Transportation Engineers (ITE), Trip Generation, 11<sup>th</sup> Edition and presented in Table 6. Traffic generated by the cumulative projects was then added to the Existing volumes to produce the Cumulative traffic forecasts. The Cumulative peak hour traffic volumes are illustrated on Figure 7.

**Table 6  
Cumulative Projects Trip Generation**

Project Name	Land Use	Size/Units	ADT	Trips	
				AM Peak Hour	PM Peak Hour
The Park Apartments	Residential	107 Units	368	47	42
Calabasas Commons	Residential	202 Units	695	89	79
Calabasas Auto Park	Auto Dealership	31,683 SF	46	6	6
Hidden Terraces Specific Plan	Residential	180 Units	583	52	54
Hidden Terraces Specific Plan	Residential	83 Beds	216	18	27
Barrett Medical Center	Medical Office	25,030 SF	901	78	98
Total Trip Generation:			2,809	290	306

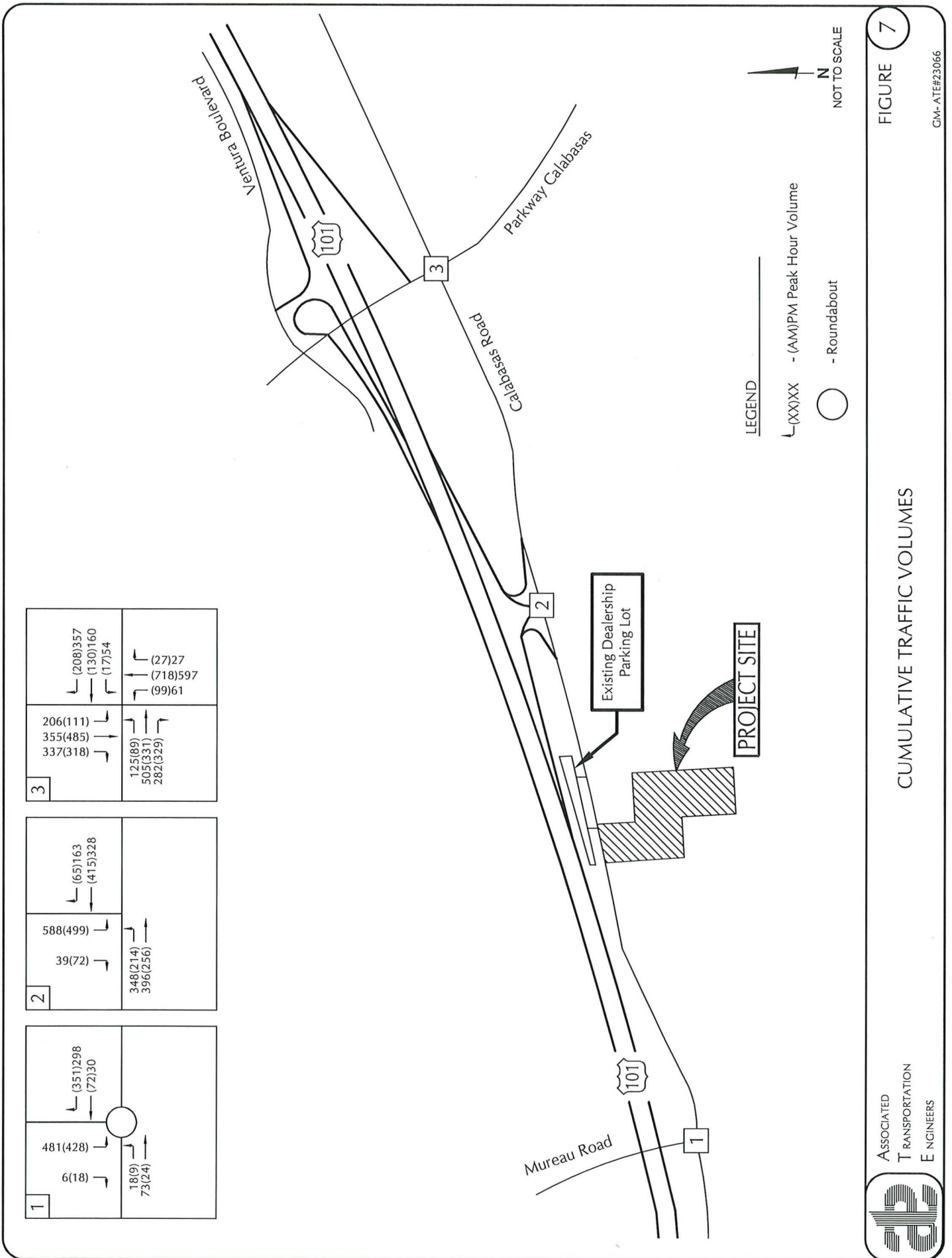

<b>1</b>	<p>481(428) ←</p> <p>6(18) ←</p> <p>18(9) ←</p> <p>73(24) ←</p> <p>○</p> <p>351(298) ←</p> <p>72(30) ←</p>	<p>348(214) →</p> <p>396(256) →</p>
<b>2</b>	<p>206(111) ←</p> <p>355(485) ←</p> <p>337(318) ←</p>	<p>125(89) →</p> <p>505(331) →</p> <p>282(329) →</p>
<b>3</b>	<p>208(357) ←</p> <p>130(160) ←</p> <p>17(54) ←</p>	<p>27(27) →</p> <p>718(597) →</p> <p>99(61) →</p>

The data presented in Table 6 indicate that the cumulative projects are estimated to generate 2,809 ADT, 290 AM peak hour trips and 306 PM peak hour trips.

Cumulative Intersection Levels of Service

Levels of service were calculated for the study-area intersections assuming the Cumulative traffic volumes illustrated on Figure 7. Table 7 presents the Cumulative AM and PM peak hour levels of service.

**Table 7  
Cumulative Peak Hour Intersection Levels of Service**

Intersection	AM Peak Hour		PM Peak Hour	
	Delay	LOS	Delay	LOS
Calabasas Road/Mureau Road <sup>(a)</sup>	7.4 Sec.	LOS A	6.1 Sec.	LOS A
U.S. Highway 101 SB Ramps/Calabasas Road	23.7 Sec.	LOS C	22.6 Sec.	LOS C
Calabasas Road/Calabasas Parkway	36.5 Sec.	LOS D	33.9 Sec.	LOS C
(a) LOS analysis assumes implementation of a single-lane roundabout.				

The data presented in Table 7 indicate that the study-area intersections would operate acceptably in the LOS A - D range with Cumulative (Existing + Approved/Pending Project) traffic volumes.

Cumulative + Project Intersection Levels of Service

Levels of service were calculated for the study-area intersections assuming the Cumulative + Project traffic volumes illustrated on Figure 8. Tables 8 and 9 compare the Cumulative and Cumulative + Project AM and PM peak hour levels of service for the study-area intersections and identify operation effects based on City policy.

**Table 8  
Cumulative + Project AM Peak Hour Levels of Service**

Intersection	Cumulative		Cumulative + Project		Project-Added	
	Delay	LOS	Delay	LOS	Delay	Exceed?
Calabasas Road/Mureau Road <sup>(a)</sup>	7.4 Sec.	LOS A	7.4 Sec.	LOS A	0.0 Sec.	NO
U.S. Highway 101 SB Ramps/Calabasas Road	23.7 Sec.	LOS C	24.1 Sec.	LOS C	0.4 Sec.	NO
Calabasas Road/Calabasas Parkway	36.5 Sec.	LOS D	36.9 Sec.	LOS D	0.4 Sec.	NO
(a) LOS analysis assumes implementation of a single-lane roundabout.						

<p><b>1</b></p> <p>486(434) → 6(18) →</p> <p>(353)305 (72)30</p> <p>18(9) → 73(24) →</p>	<p><b>2</b></p> <p>588(499) → 57(99) →</p> <p>(65)163 (447)351</p> <p>372(222) → 435(270) →</p>	<p><b>3</b></p> <p>206(111) → 355(485) → 355(344) →</p> <p>(208)357 (133)163 (17)54</p> <p>157(99) → 509(333) → 285(331) →</p> <p>(27)27 ↑ (7)8)597 ↑ (102)63</p>
--	---	---

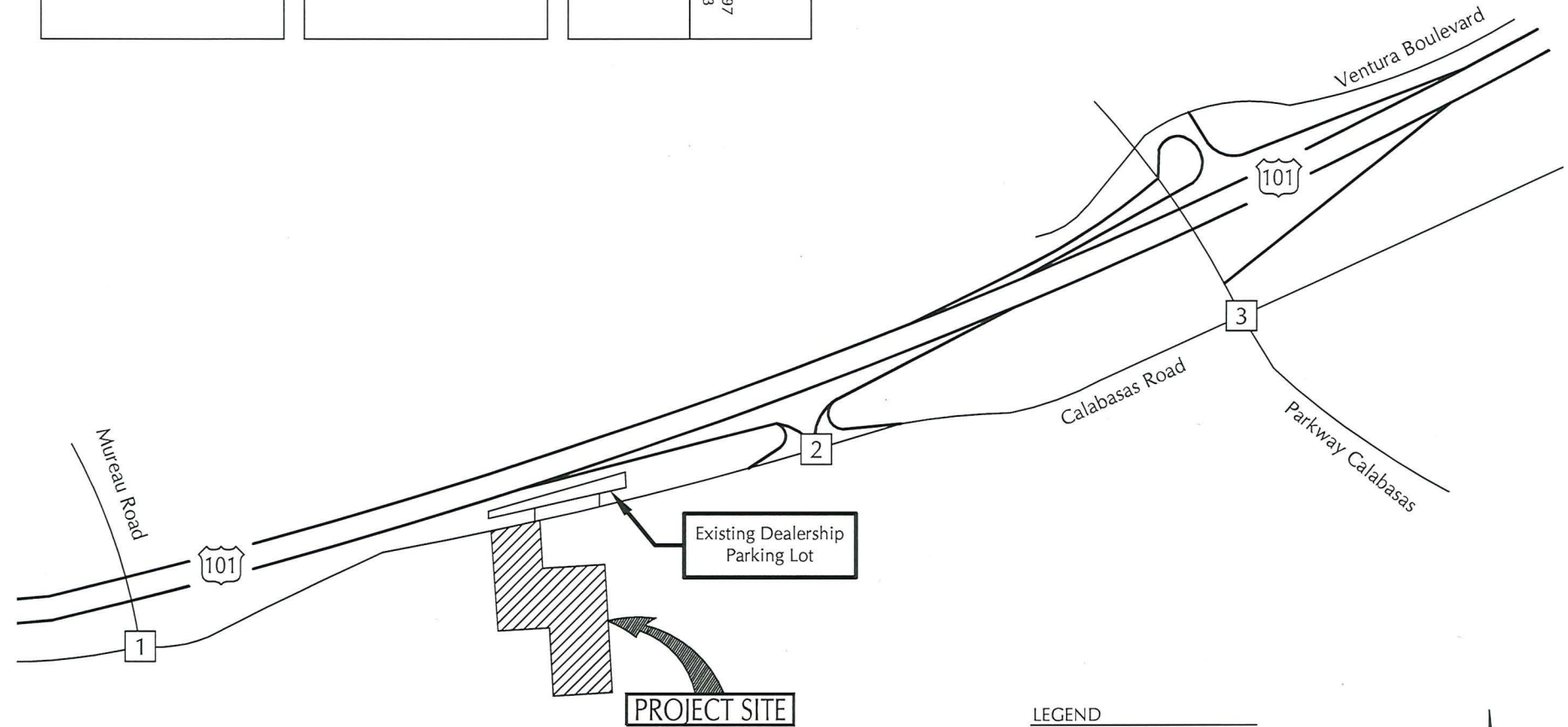

LEGEND

- ↳(XX)XX - (AM)PM Peak Hour Volume
- - Roundabout

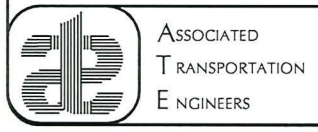

CUMULATIVE + PROJECT TRAFFIC VOLUMES

FIGURE 8

GM- ATE#23066

**Table 9**  
**Cumulative + Project PM Peak Hour Levels of Service**

Intersection	Cumulative		Cumulative + Project		Project-Added	
	Delay	LOS	Delay	LOS	Delay	Exceed?
Calabasas Road/Mureau Road <sup>(a)</sup>	6.1 Sec.	LOS A	6.2 Sec.	LOS A	0.1 Sec.	NO
U.S. Highway 101 SB Ramps/Calabasas Road	22.6 Sec.	LOS C	22.9 Sec.	LOS C	0.3 Sec.	NO
Calabasas Road/Calabasas Parkway	33.9 Sec.	LOS C	34.0 Sec.	LOS C	0.1 Sec.	NO
(a) LOS analysis assumes implementation of a single-lane roundabout.						

The data presented in Tables 8 and 9 indicate that with the addition of Project traffic, the study-area intersections would continue to operate in the LOS A - D range. For City operated signalized intersections already operating at LOS D, E or F under baseline conditions, an adverse effect is defined as an increase of 5 seconds or more. The Project would not have an adverse effect on intersection operations based on the City's intersection operation policy.

**SITE ACCESS AND CIRCULATION**

Access to the site would be provided via a relocated driveway connection (26 feet wide) to Calabasas Road (see Figure 2 - Project Site Plan). The Project driveway will be designed and constructed to City of Calabasas design standards and allow full access. Figures 9 and 10 illustrate the turning movements for vehicles entering and exiting the site. As illustrated on the figures, adequate space is provided for vehicles to make the turning maneuvers with good visibility. Car carrier delivery trucks would not be able enter the site via the Project driveway. Instead, new vehicles would be unloaded off-site and then driven on-site or stored in other off-site lots. It is estimated that there would be approximately 6 car carrier deliveries per month between the hours of 7:00 AM and 6:00 PM.

The section of Calabasas Road adjacent to the site has not been fully improved with curb, gutter, sidewalk, and street lighting. The Project would be required to complete the frontage improvements as illustrated on Figure 11. As shown on the figure, the existing center turn lane on Calabasas Road would be extended to the Project frontage. An on-street loading zone would also be provided adjacent to the Project site to accommodate the car carrier trucks. The car carrier trucks would also be able to use the extended center turn lane to unload vehicles, which is a typical delivery practice for the other dealerships along Calabasas Road.

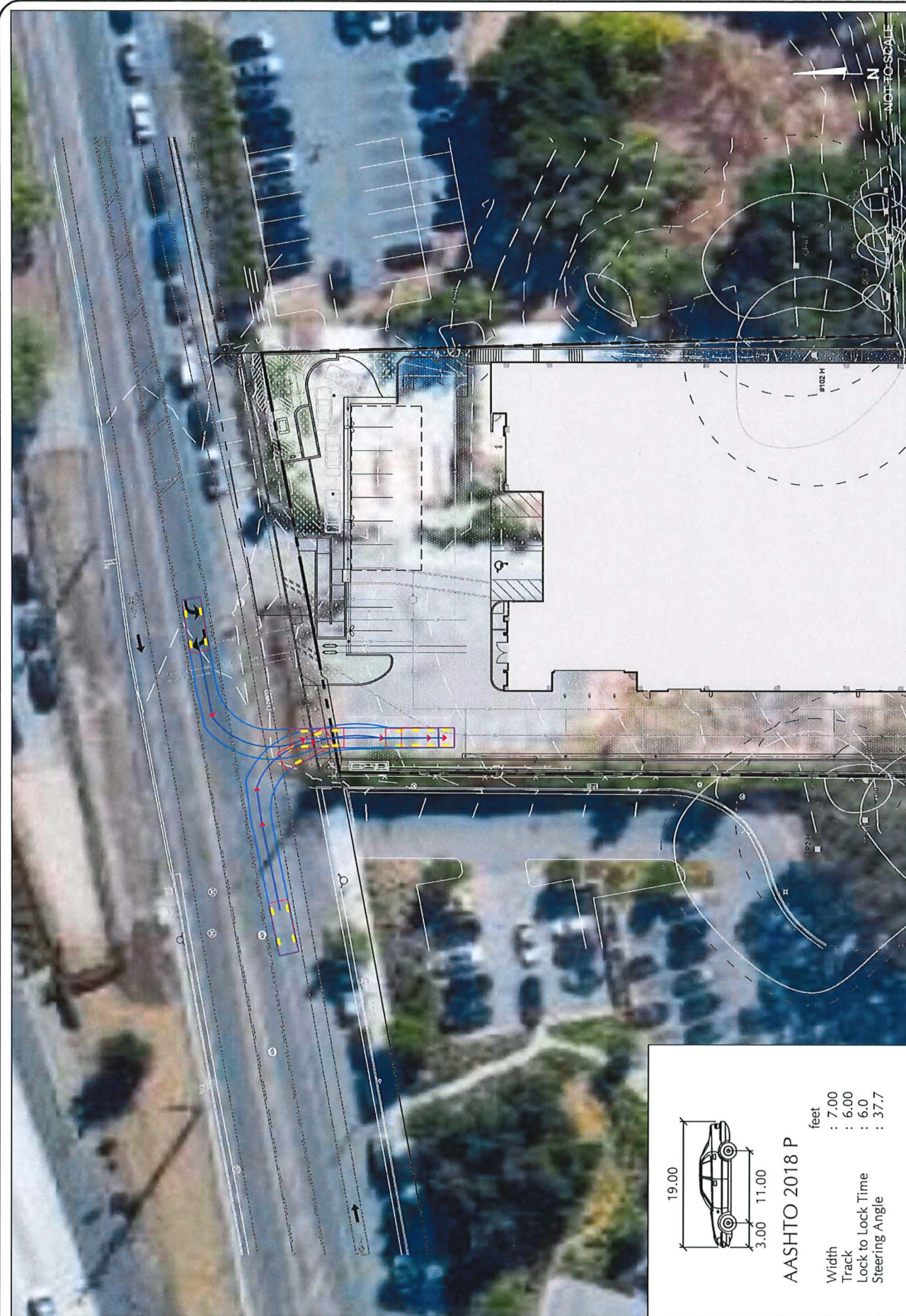
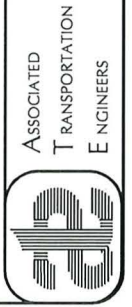

FIGURE 9

INGRESS TURNING MOVEMENTS



ASSOCIATED  
TRANSPORTATION  
ENGINEERS

GM-ATE#23066



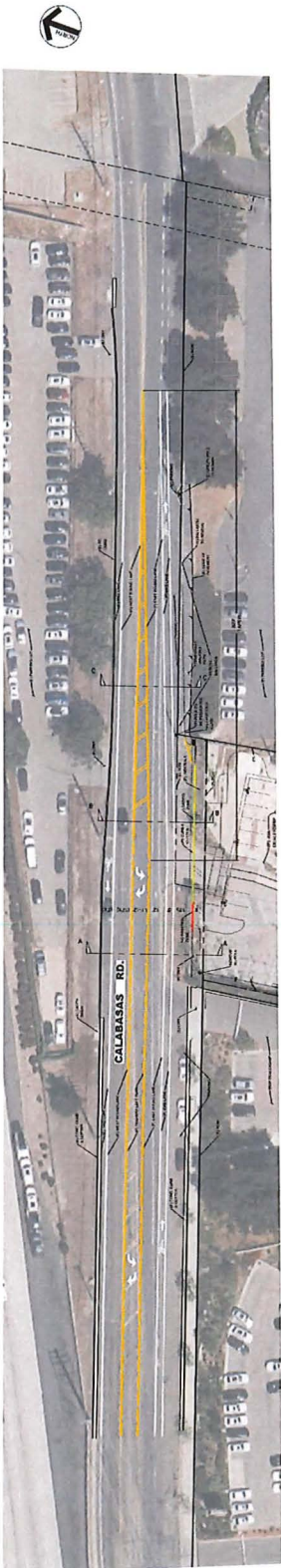

\*Vehicle deliveries will occur in the proposed loading zone. It is anticipated that this will not result in truck per inch between Turn-Left Merge/Queue.

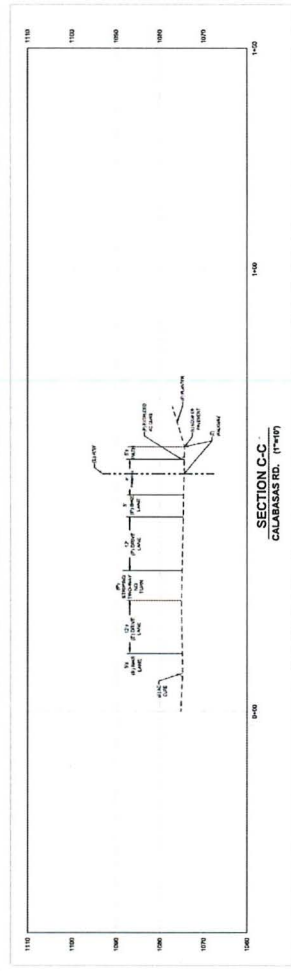
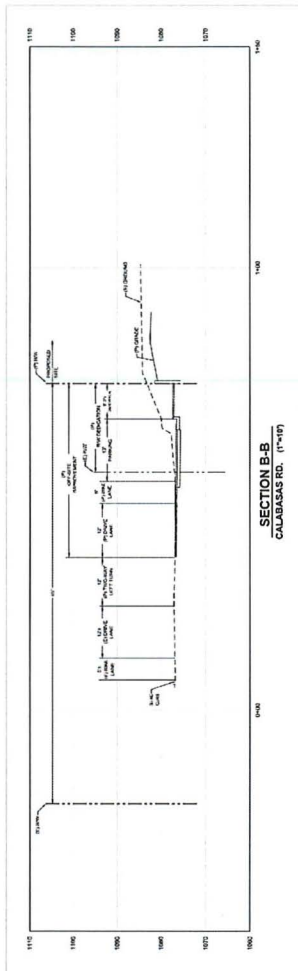
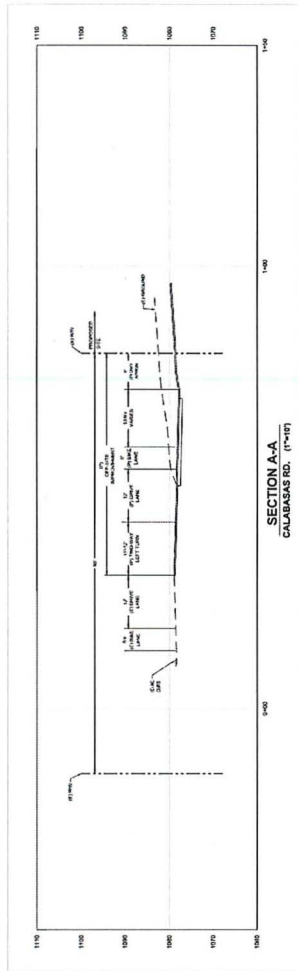

NOT TO SCALE

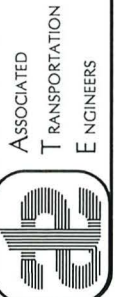

ASSOCIATED  
 TRANSPORTATION  
 ENGINEERS

PROJECT FRONTAGE IMPROVEMENT

FIGURE 11

CM- ATE#23066

## Sight Distance



Adjacent to the Project site, Calabasas Road is relatively straight and level. A sight distance analysis was completed at the proposed driveway location to determine if there would be adequate intervisibility between a driver exiting from the driveway and a vehicle traveling on Calabasas Road. The posted speed limit on Calabasas Road is 40 mph adjacent to the driveway. The AASHTO minimum corner sight distance for a 40-mph design speed is 440 feet. As illustrated on Figure 12, the sight

distance looking to the east and west from the driveway satisfies the AASHTO 440-foot corner sight distance requirement. The AASHTO minimum stopping sight distance for a 40-mph design speed is 300 feet. As illustrated on Figure 13, the sight distance looking from the east and west of the driveway satisfies the AASHTO 300-foot stopping sight distance requirement.

It was noted that vehicles currently park along the curb adjacent to the Project driveway. These parked vehicles could block the sight distance of drivers exiting the Project driveway. It is therefore recommended that a Red Curb "No Parking" zone be installed on Calabasas Road east and west of the Project driveway (50 feet to east and west). It is also noted that the existing landscaping along the frontage of the Project while looking east and west along Calabasas Road needs to be maintained at a height of less than 3.5 feet in order to provide intervisibility between eastbound and westbound traffic on Calabasas Road and traffic exiting the Project driveway.

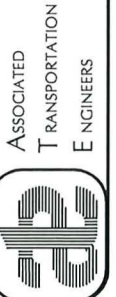
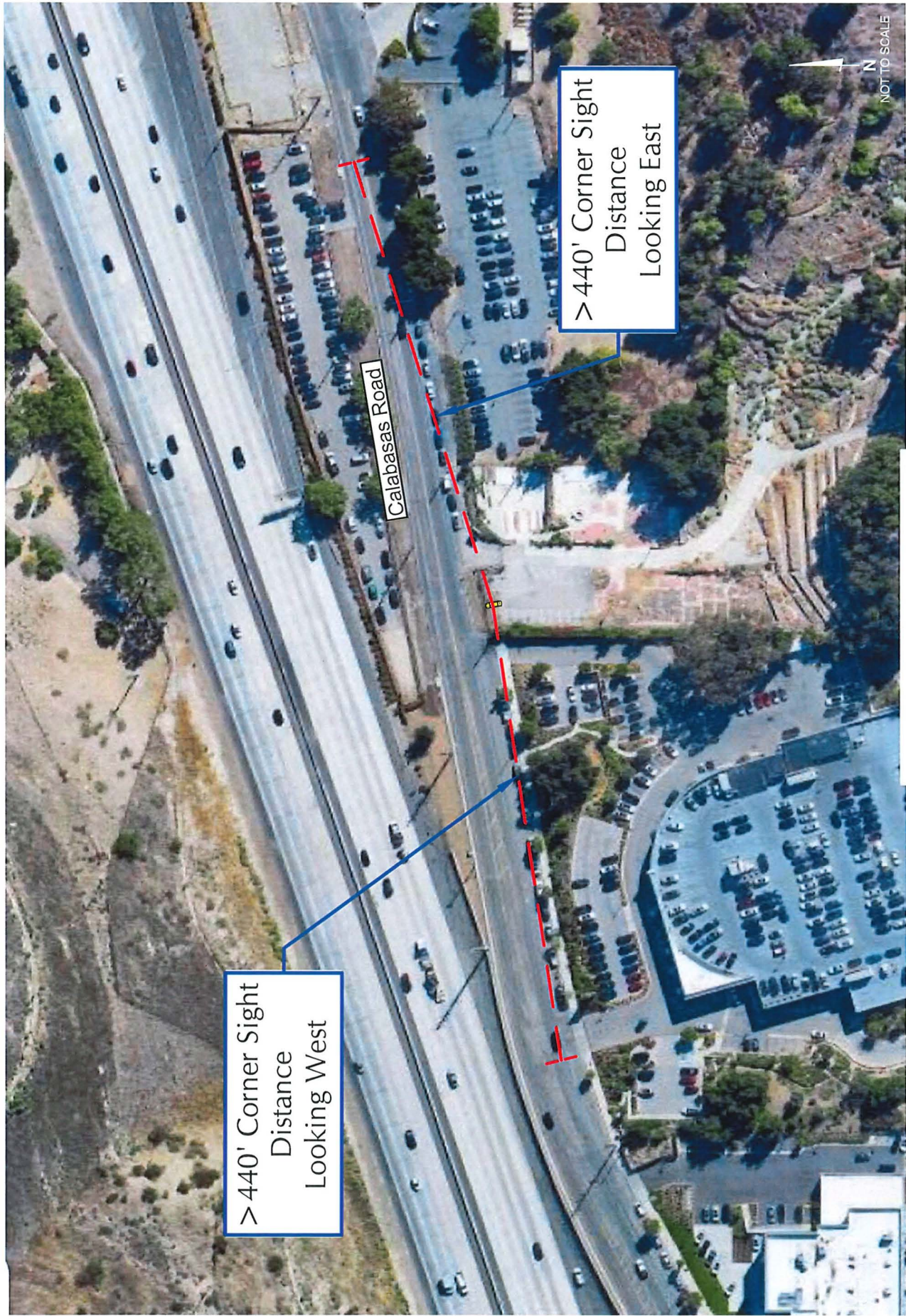

ASSOCIATED  
TRANSPORTATION  
ENGINEERS

PROJECT DRIVEWAY CORNER SIGHT DISTANCES

FIGURE 12

GM-ATE#23066



FIGURE 13

PROJECT DRIVEWAY STOPPING SIGHT DISTANCES

CM-ATE#23066

ASSOCIATED  
TRANSPORTATION  
ENGINEERS



**PARKING ANALYSIS**

Zoning Ordinance Parking Requirements

The City of Calabasas Zoning Ordinance parking requirements were calculated for the Project based on the rates established for the Commercial Office Zoning District (CO) Zone. The parking space requirement is based on the following specifications for Car Dealerships:

- Motor Vehicle and Parts Sales - 1 space for each 450 sq.ft. of gross floor area for showroom and office, plus 1 space for each 2,000 sq.ft. of outdoor display area, plus 1 space for each 500 sq.ft. of gross floor area for vehicle repair, plus 1 space of each 300 sq.ft. of gross floor area for the parts department.

Table 10 presents the City Zoning Ordinance parking requirements for the Kia of Calabasas.

**Table 10  
Zoning Ordinance Parking Requirements**

Land-Use	Building Area	Zoning Ordinance Requirement	Required Parking Spaces
Car Sales	13,662 sq.ft. Showroom/Office Area	1 Space/per 450 sq.ft.	31 Vehicle Spaces
	969 sq.ft. Outdoor Display Area	1 Space/per 2,000 sq.ft.	42 Vehicle Spaces
	20,737 sq.ft. Vehicle Repair Area	1 Space/per 500 sq.ft.	1 Vehicle Space
	1,356 sq.ft. Parts Department	1 Space/per 300 sq.ft.	5 Vehicle Spaces
Total Parking Requirement:			79 Spaces
Parking Provided:			79 Spaces

The data presented in Table 10 indicate that the City Zoning Ordinance parking requirement is 79 vehicle parking spaces. The 79 on-site vehicle parking spaces provided would satisfy the City’s requirements.



## REFERENCES AND PERSONS CONTACTED

### Associated Transportation Engineers

Scott A. Schell, Principal Planner  
Darryl F. Nelson, Senior Transportation Planner  
Glenn O. Manaois, Transportation Engineer I

### References

Transportation Analysis Handbook, City of Calabasas, April 2020.

Highway Capacity Manual, 6<sup>th</sup> Edition, Transportation Research Board, 2016.

Trip Generation, Institute of Transportation Engineers, 11<sup>th</sup> Edition, 2020.

Envision Calabasas 2040 General Plan, City of Calabasas, July 2022.

### Persons Contacted

Tom Mericle, P.E. Traffic Engineer, City of Calabasas

## TECHNICAL APPENDIX

### CONTENTS:

LEVEL OF SERVICE DEFINITIONS

CITY OF CALABASAS LOCAL TRANSPORTATION STUDY CHECKLIST/SCOPE OF WORK

TRAFFIC COUNTS

INTERSECTION LEVEL OF SERVICE CALCULATION WORKSHEETS

- Reference 1 - Calabasas Road/Mureau Road
- Reference 2 - U.S. Highway 101 Southbound Ramps/Calabasas Road
- Reference 3 - Calabasas Road/Calabasas Parkway

CITY OF CALABASAS APPROVED DEVELOPMENT PROJECTS

## **LEVEL OF SERVICE DEFINITIONS**

## LEVEL OF SERVICE DEFINITIONS

"Levels of Service" (LOS) A through F are used to rate roadway and intersection operating conditions, with LOS A indicating very good operations and LOS F indicating poor operations. More complete level of service definitions are:

LOS	Definition
A	Low volumes; primarily free flow operations. Density is low and vehicles can freely maneuver within traffic stream. Drivers can maintain their desired speeds with little or no delay.
B	Stable flow with potential for some restriction of operating speeds due to traffic conditions. Maneuvering is only slightly restricted. Stopped delays are not bothersome and drivers are not subject to appreciable tension.
C	Stable operations, however the ability to maneuver is more restricted by the increase in traffic volumes. Relatively satisfactory operating speeds prevail but adverse signal coordination or longer queues cause delays.
D	Approaching unstable traffic flow where small increases in volume could cause substantial delays. Most drivers are restricted in their ability to maneuver and their selection of travel speeds. Comfort and convenience are low but tolerable.
E	Operations characterized by significant approach delays and average travel speeds of one-half to one-third of free flow speed. Flow is unstable and potential for stoppages of brief duration. High signal density, extensive queuing, or signal progression/timing are the typical causes of delays.
F	Forced flow operations with high approach delays at critical signalized intersections. Speeds are reduced substantially and stoppages may occur for short or long periods of time because of downstream congestion.

### Signalized Intersection Level of Service Definitions

LOS	Delay <sup>a</sup>	V/C Ratio	Definition
A	< 10.0	< 0.60	Progression is extremely favorable. Most vehicles arrive during the green phase. Many vehicles do not stop at all.
B	10.1 - 20.0	0.61 - 0.70	Good progression, short cycle lengths, or both. More vehicles stop than with LOS A, causing higher levels of delay.
C	20.1 - 35.0	0.71 - 0.80	Only fair progression, longer cycle lengths, or both, result in higher cycle lengths. Cycle lengths may fail to serve queued vehicles, and overflow occurs. Number of vehicles stopped is significant, though many still pass through intersection without stopping.
D	35.1 - 55.0	0.81 - 0.90	Congestion becomes more noticeable. Unfavorable progression, long cycle lengths and high v/c ratios result in longer delays. Many vehicles stop, and the proportion of vehicles not stopping declines. Individual cycle failures are noticeable.
E	55.1 - 80.0	0.91 - 1.00	High delay values indicate poor progression, long cycle lengths and high v/c ratios. Individual cycle failures are frequent
F	> 80.0	> 1.00	Considered unacceptable for most drivers, this level occurs when arrival flow rates exceed the capacity of lane groups, resulting in many individual cycle failures. Poor progression and long cycle lengths may also contribute to high delay levels.

<sup>a</sup> Average control delay per vehicle in seconds.

### Unsignalized Intersection Level of Service Definitions

The HCM<sup>1</sup> uses *control delay* to determine the level of service at unsignalized intersections. Control delay is the difference between the travel time actually experienced at the control device and the travel time that would occur in the absence of the traffic control device. Control delay includes deceleration from free flow speed, queue move-up time, stopped delay and acceleration back to free flow speed.

LOS	Control Delay Seconds per Vehicle
A	< 10.0
B	10.1 - 15.0
C	15.1 - 25.0
D	25.1 - 35.0
E	35.1 - 50.0
F	> 50.0

<sup>1</sup> Highway Capacity Manual, National Research Board, 2000



**CITY OF CALABASAS LOCAL TRANSPORTATION STUDY  
CHECKLIST/SCOPE OF WORK**



## CITY of CALABASAS

### LOCAL TRANSPORTATION STUDY CHECKLIST

This checklist will be used to screen land development projects to determine if they may be presumed to have no significant CEQA transportation impacts, if they need to have a formal VMT traffic study, and if they need to have a Local Transportation Operational Assessment. The process will include the following steps as outlined below.

**Date of Review:** January 19, 2023  
**Project Name:** KIA Car Dealership – 24460 Calabasas Road  
**Project Description:** 47,944 SF Car Dealer  
**Reviewed By:** Tom Mericle, TKM Engineering for City of Calabasas

#### Summary:

- Needs TIA NO
- Needs LTA YES

#### Comments:

From both an employee trip and customer trip perspective the project will have a less than significant CEQA transportation impact on regional VMT. However, the new local peak hour trips generated by the project may have a local transportation operations or safety impact and a local transportation analysis will need to be prepared to determine if and what level of operation or safety impact may occur.

### Transportation Environmental Impact Analysis for CEQA Compliance (TIA)

#### Step 1: Check Project Type:

Meet: YES

Certain project types can be presumed to improve, have no impact to, or have a less than significant impact. The following type generally improve regional VMT or have no impact:

- Maintenance of existing facilities
- Installation of safety devices
- Installation of traffic control devices
- Installation of bicycle or pedestrian facilities
- Reducing the number or width of existing vehicle lanes
- Modifications to on-street parking
- Adding alternative fuel charging infrastructure

Local serving retail projects generally improve the convenience of shopping close to home and has the effect of reducing regional vehicle travel. This could be applied to individual businesses in a community-based shopping center. Similarly, adding local neighborhood serving parks and schools can reduce vehicle travel from facilities located further away. The following types of uses could be presumed to have a less than significant impact as their uses are local serving in nature:

- Local-serving retail establishments (less than 50,000 sf each)
- Local-serving K-12 schools
- Local parks
- Day care centers
- Local-serving gas stations
- Local-serving banks
- Local-serving medical offices
- Local-serving community assembly uses (community organizations, places of worship, etc.)
- Local-serving restaurants
- Local-serving hotels (e.g. non-destination hotels)
- Student housing projects
- Local serving community colleges that are consistent with the assumptions in the Regional Transportation Plan and Sustainable Community Strategy
- Projects generating less than 110 daily vehicle trips. The City would estimate trip generation for a project that may fall in this area and compare it to the 110 daily trip limit criteria. This generally corresponds to the following “typical” development:
  - 11 single family housing units
  - 16 multi-family, condominiums, or townhouse housing units
  - 10,000 sq. ft. of office
  - 15,000 sq. ft. of light industrial
  - 63,000 sq. ft. of warehousing
  - 79,000 sq. ft. of high cube transload and short-term storage warehouse
- Other locally serving land uses as determined by the Community Development Director

Project land use: Car Dealership Project size: 47,944 sf

Comments: If reviewed from a customer perspective, a new KIA car dealership would reduce local Calabasas, Agoura Hills, and west SF Valley residents from going to either the existing Simi Valley or Van Nuys Kia dealership.

**Step 2: Check for Low VMT Area**

**Meet: YES**

Residential and office land use type projects located within a low VMT-generating area may be presumed to have a less than significant impact since the travel patterns will be similar to existing for the same uses. In addition, other employment-related and mixed-use land use projects may be screened if the project can reasonably be expected to generate VMT per resident, per worker, or per service population that is similar to the existing land uses in the low VMT area. Low VMT-generating areas are mapped using the SCAG regional traffic model.

The reviewer needs to identify that the project is consistent with the existing land uses within the traffic analysis zone and use professional judgement that there is nothing unique about the project that would otherwise be misrepresented utilizing the data from the travel demand model.

Comments: The project is in a low employee VMT area. If the project is considered as a home-based work trip rather than a customer commercial trip it is in a low work based trip VMT area and would have a less than significant VMT impact.

**Step 3: Check for Transit Priority Area (TPA) Screening**

**Meet: NO**

Projects located within a TPA may be presumed to have a less than significant impact. Transit priority areas are defined as ½ mile from an existing High-Quality Transit Corridor (15 min headway or better during peak periods) stop or ½ mile around an existing major transit stop such as a Metrolink station or regional bus service stop. Unfortunately, the City does not currently have transit services that would qualify as high-quality transit.

**Full VMT Analysis**

**Required: NO**

Projects not screened through the steps will need to complete a VMT analysis and forecasting through the SCAG regional traffic model to determine the projected VMT from the development project. The VMT would then be compared to the following City’s adopted threshold to determine if there is a significant impact or less than significant impact for CEQA compliance:

1. A significant transportation impact would occur for land use projects under one of the following conditions:
  - a. For residential land use projects if the project generated home-based VMT exceeds 15% below the citywide baseline VMT per capita.
  - b. For commercial or industrial land use projects if the project generated home-based work VMT exceeds 15% below the citywide baseline average VMT per employee.
  - c. For regional retail land use projects if the project generates a net increase in total VMT in comparison to the citywide baseline VMT.
  - d. For land use plans if the plan generates a net increase in total VMT in comparison to the citywide baseline average VMT per service population.

2. For mixed use projects each land use component will be evaluated separately using the criteria above.
3. For other types of land use projects City staff will determine the appropriate VMT metric depending on the project characteristics. A significant impact would occur if the project exceeds 15% below citywide baseline VMT or if the project results in a net increase in Total VMT
4. A significant transportation impact would occur for transportation projects if the project results in a net increase in total VMT in the City compared to baseline conditions.

Projects that have to prepare a full VMT analysis may need to also comply with Caltrans requirements for VMT impact evaluation depending on proximity to a Caltrans facility.

### **Local Transportation Operational Assessment (LTA)**

**Check Estimated Project Trip Generation:**

**Meet: YES**

Projects that generate less than 110 daily vehicle trips typically do not have to prepare a formal LTA that determines levels of service or other roadway operational impacts. However, they project will still need to be reviewed through the development review process for site circulation, safety, and bicyclist/pedestrian safety access. Projects that are estimated to generate 110 daily trips or more will have to prepare a formal LTA.

Project is projected to generate 1,335 daily trips and will be required to prepare a local transportation operational assessment.

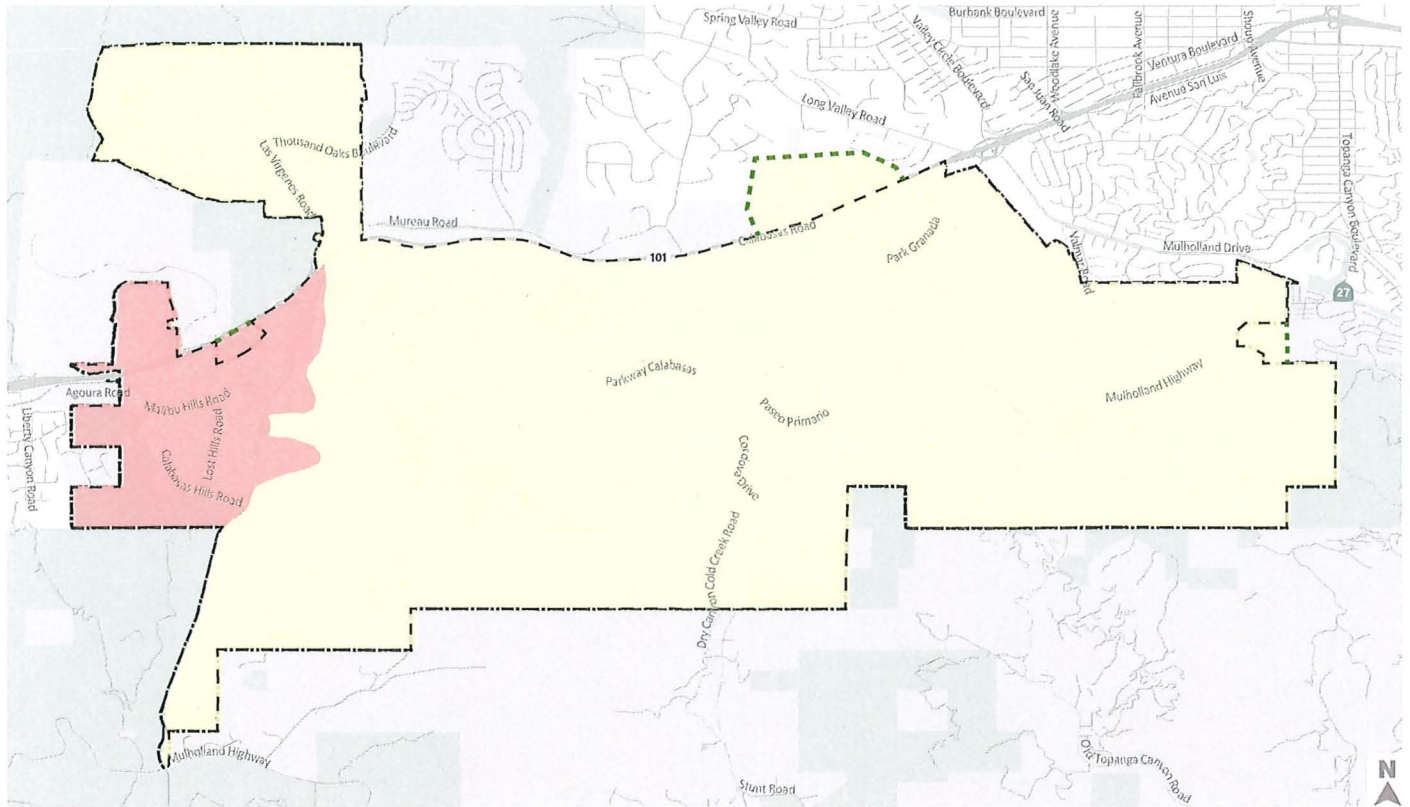

Home-Based Work VMT per Employee Comparison    City Boundary  
 0 to 15% Below City Average    City Sphere of Influence  
 Higher than City Average



Low VMT Screening:  
Office (2021)

## Darryl Nelson

---

**From:** Tom Mericle <tmericle@cityofcalabasas.com>  
**Sent:** Friday, July 14, 2023 10:03 AM  
**To:** Darryl Nelson  
**Cc:** Tom Mericle  
**Subject:** Re: City of Carpinteria  
**Attachments:** Calabasas\_Traffic\_Study\_Guidelines\_FINAL\_July 2021.pdf; Traffic Study Screening Checklist\_KIA.pdf; Traffic Count Data.pdf; Cumulative Project List.pdf

Darryl,

This is my Calabasas email account.

Attached are the City's traffic study preparation guidelines and the VMT screening checklist. I already screened it out of VMT via the attached checklist. Therefore, you only have to do the Local Transportation Assessment (LTA). All of the criteria are in the guidelines.

The intersections to look at will be:

- Calabasas Road and Mureau Road
- Calabasas Road and Ventura Freeway Southbound on and off ramps
- Calabasas Road and Parkway Calabasas

I have the counts already from a medical office building near the site that was taken in February 2023. You can use the City as reference for the data. Another consultant collected this but is part of the public record since they submitted their study for review. It has not yet been approved.

Also attached is the cumulative project list from that study.

Let me know if you have any other questions.

Thank you,  
Tom

**Thomas Mericle, PE, TE**

City of Calabasas  
Contract Traffic Engineering Services  
(805) 701-2977

## TRAFFIC COUNTS

**CITY TRAFFIC COUNTERS**  
**WWW.CTCOUNTERS.COM**

File Name : MureauRd\_CalabasasRd  
 Site Code : 00000000  
 Start Date : 2/1/2023  
 Page No : 1

Groups Printed- Vehicles

Start Time	Mureau Road Southbound			Calabasas Road Westbound			Northbound			Calabasas Road Eastbound			Int. Total
	Left	Thru	Right	Left	Thru	Right	Left	Thru	Right	Left	Thru	Right	
06:00 AM	17	0	0	0	6	8	0	0	0	0	7	0	38
06:15 AM	14	0	1	0	1	5	0	0	0	1	6	0	28
06:30 AM	22	0	0	0	2	10	0	0	0	1	3	0	38
06:45 AM	31	0	0	0	10	33	0	0	0	0	1	0	75
Total	84	0	1	0	19	56	0	0	0	2	17	0	179
07:00 AM	25	0	1	0	3	25	0	0	0	3	0	0	57
07:15 AM	36	0	1	0	0	43	0	0	0	0	1	0	81
07:30 AM	80	0	1	0	0	89	0	0	0	3	1	0	174
07:45 AM	133	0	0	0	5	111	0	0	0	1	2	0	252
Total	274	0	3	0	8	268	0	0	0	7	4	0	564
08:00 AM	130	0	2	0	6	64	0	0	0	0	6	0	208
08:15 AM	54	0	2	0	11	57	0	0	0	1	1	0	126
08:30 AM	53	0	0	0	7	58	0	0	0	1	3	0	122
08:45 AM	75	0	0	0	13	65	0	0	0	0	5	0	158
Total	312	0	4	0	37	244	0	0	0	2	15	0	614
04:00 PM	157	0	0	0	10	79	0	0	0	0	5	0	251
04:15 PM	137	0	2	0	5	70	0	0	0	3	15	0	232
04:30 PM	146	0	0	0	10	71	0	0	0	1	9	0	237
04:45 PM	110	0	0	0	1	64	0	0	0	2	2	0	179
Total	550	0	2	0	26	284	0	0	0	6	31	0	899
05:00 PM	130	0	0	0	2	62	0	0	0	0	6	0	200
05:15 PM	90	0	0	0	1	60	0	0	0	1	5	0	157
05:30 PM	107	0	0	0	0	61	0	0	0	1	4	0	173
05:45 PM	112	0	0	0	2	72	0	0	0	1	2	0	189
Total	439	0	0	0	5	255	0	0	0	3	17	0	719
Grand Total	1659	0	10	0	95	1107	0	0	0	20	84	0	2975
Apprch %	99.4	0	0.6	0	7.9	92.1	0	0	0	19.2	80.8	0	
Total %	55.8	0	0.3	0	3.2	37.2	0	0	0	0.7	2.8	0	

**CITY TRAFFIC COUNTERS**  
**WWW.CTCOUNTERS.COM**

File Name : MureauRd\_CalabasasRd  
 Site Code : 00000000  
 Start Date : 2/1/2023  
 Page No : 2

Start Time	Mureau Road Southbound				Calabasas Road Westbound				Northbound				Calabasas Road Eastbound				Int. Total
	Left	Thru	Right	App. Total	Left	Thru	Right	App. Total	Left	Thru	Right	App. Total	Left	Thru	Right	App. Total	
Peak Hour Analysis From 06:00 AM to 09:45 AM - Peak 1 of 1																	
Peak Hour for Entire Intersection Begins at 07:30 AM																	
07:30 AM	80	0	1	81	0	0	89	89	0	0	0	0	3	1	0	4	174
07:45 AM	133	0	0	133	0	5	111	116	0	0	0	0	1	2	0	3	252
08:00 AM	130	0	2	132	0	6	64	70	0	0	0	0	0	6	0	6	208
08:15 AM	54	0	2	56	0	11	57	68	0	0	0	0	1	1	0	2	126
Total Volume	397	0	5	402	0	22	321	343	0	0	0	0	5	10	0	15	760
% App. Total	98.8	0	1.2		0	6.4	93.6		0	0	0		33.3	66.7	0		
PHF	.746	.000	.625	.756	.000	.500	.723	.739	.000	.000	.000	.000	.417	.417	.000	.625	.754

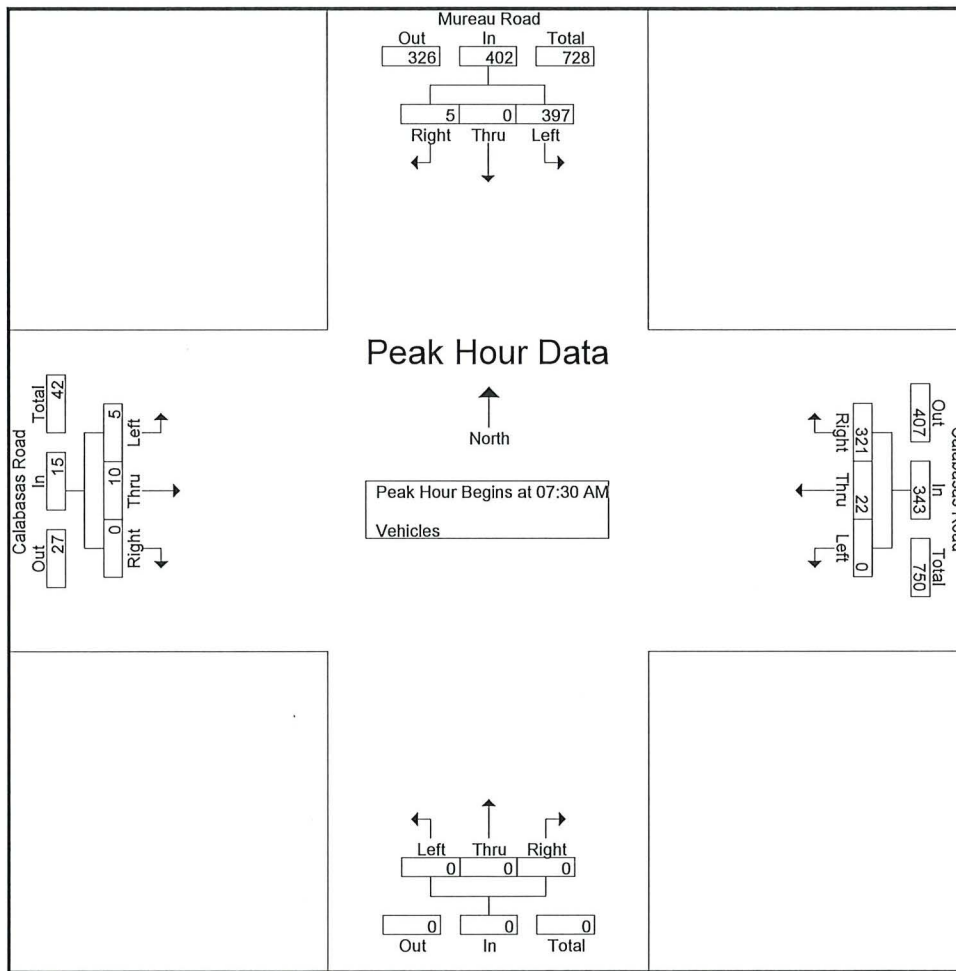

**CITY TRAFFIC COUNTERS**  
**WWW.CTCOUNTERS.COM**

File Name : MureauRd\_CalabasasRd  
 Site Code : 00000000  
 Start Date : 2/1/2023  
 Page No : 3

Start Time	Mureau Road Southbound				Calabasas Road Westbound				Northbound				Calabasas Road Eastbound				Int. Total	
	Left	Thru	Right	App. Total	Left	Thru	Right	App. Total	Left	Thru	Right	App. Total	Left	Thru	Right	App. Total		
Peak Hour Analysis From 04:45 PM to 05:45 PM - Peak 1 of 1																		
Peak Hour for Entire Intersection Begins at 05:00 PM																		
05:00 PM	130	0	0	130	0	2	62	64	0	0	0	0	0	6	0	0	6	200
05:15 PM	90	0	0	90	0	1	60	61	0	0	0	0	1	5	0	0	6	157
05:30 PM	107	0	0	107	0	0	61	61	0	0	0	0	1	4	0	0	5	173
05:45 PM	112	0	0	112	0	2	72	74	0	0	0	0	1	2	0	0	3	189
Total Volume	439	0	0	439	0	5	255	260	0	0	0	0	3	17	0	0	20	719
% App. Total	100	0	0		0	1.9	98.1		0	0	0	0	15	85	0			
PHF	.844	.000	.000	.844	.000	.625	.885	.878	.000	.000	.000	.000	.750	.708	.000	.833	.899	

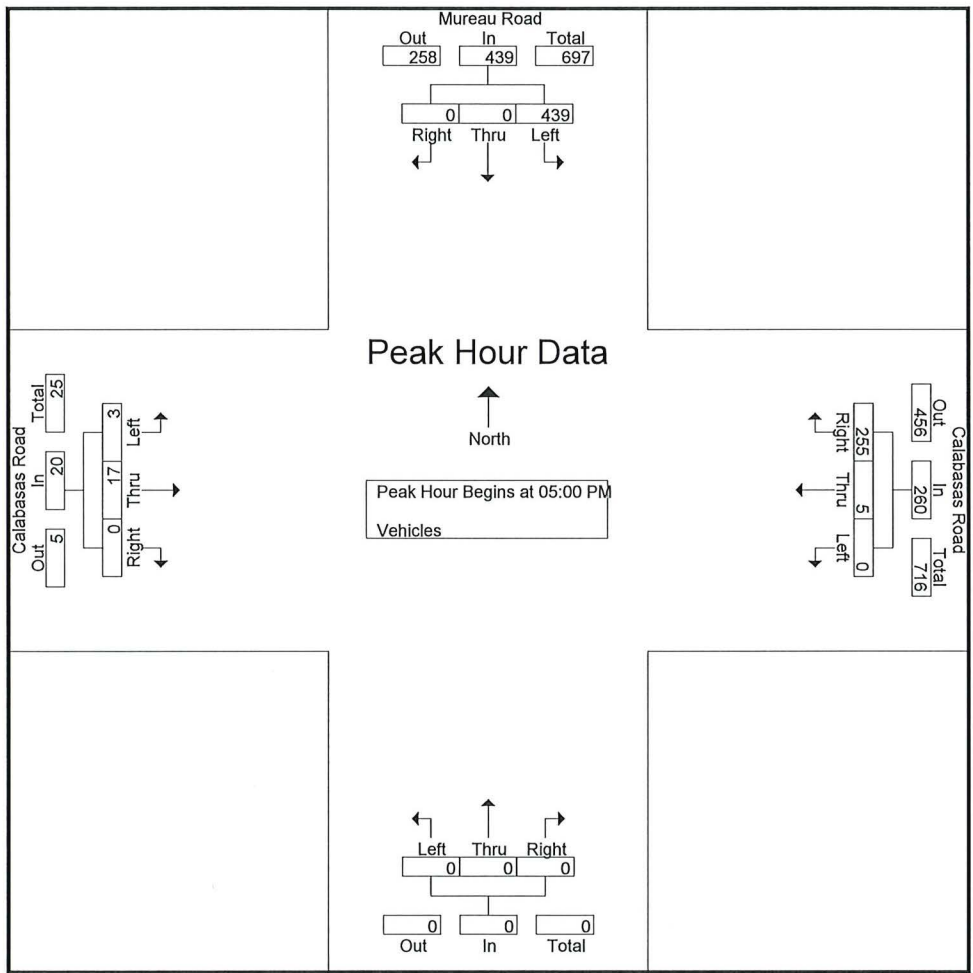

**CITY TRAFFIC COUNTERS**  
**WWW.CTCOUNTERS.COM**

File Name : 101FreewaySBRamps\_CalabasasRd  
 Site Code : 00000000  
 Start Date : 2/1/2023  
 Page No : 1

Groups Printed- Vehicles

Start Time	101 Freeway Southbound On/Off Ramps Southbound			Calabasas Road Westbound			Northbound			Calabasas Road Eastbound			Int. Total
	Left	Thru	Right	Left	Thru	Right	Left	Thru	Right	Left	Thru	Right	
06:00 AM	19	0	2	0	19	6	0	0	0	12	5	0	63
06:15 AM	15	0	0	0	16	5	0	0	0	14	5	0	55
06:30 AM	23	0	1	0	17	5	0	0	0	19	2	0	67
06:45 AM	45	0	5	0	45	12	0	0	0	20	13	0	140
Total	102	0	8	0	97	28	0	0	0	65	25	0	325
07:00 AM	46	0	7	0	31	10	0	0	0	20	11	0	125
07:15 AM	80	0	11	0	49	4	0	0	0	18	13	0	175
07:30 AM	78	0	16	0	90	2	0	0	0	31	36	0	253
07:45 AM	123	0	14	0	127	7	0	0	0	43	78	0	392
Total	327	0	48	0	297	23	0	0	0	112	138	0	945
08:00 AM	121	0	12	0	90	9	0	0	0	71	96	0	399
08:15 AM	118	0	11	0	83	8	0	0	0	33	34	0	287
08:30 AM	116	0	11	0	70	15	0	0	0	26	34	0	272
08:45 AM	149	0	15	0	87	7	0	0	0	39	63	0	360
Total	504	0	49	0	330	39	0	0	0	169	227	0	1318
04:00 PM	100	0	9	0	88	40	0	0	0	88	86	0	411
04:15 PM	140	0	3	0	70	29	0	0	0	63	104	0	409
04:30 PM	157	0	5	0	82	33	0	0	0	64	86	0	427
04:45 PM	153	0	4	0	63	47	0	0	0	56	83	0	406
Total	550	0	21	0	303	149	0	0	0	271	359	0	1653
05:00 PM	122	0	6	0	54	61	0	0	0	64	80	0	387
05:15 PM	129	0	3	0	73	45	0	0	0	46	80	0	376
05:30 PM	133	0	3	0	57	43	0	0	0	35	93	0	364
05:45 PM	131	0	2	0	85	32	0	0	0	50	87	0	387
Total	515	0	14	0	269	181	0	0	0	195	340	0	1514
Grand Total	1998	0	140	0	1296	420	0	0	0	812	1089	0	5755
Apprch %	93.5	0	6.5	0	75.5	24.5	0	0	0	42.7	57.3	0	
Total %	34.7	0	2.4	0	22.5	7.3	0	0	0	14.1	18.9	0	

**CITY TRAFFIC COUNTERS**  
**WWW.CTCOUNTERS.COM**

File Name : 101FreewaySBRamps\_CalabasasRd  
 Site Code : 00000000  
 Start Date : 2/1/2023  
 Page No : 2

Start Time	101 Freeway Southbound On/Off Ramps Southbound				Calabasas Road Westbound				Northbound				Calabasas Road Eastbound				Int. Total	
	Left	Thru	Right	App. Total	Left	Thru	Right	App. Total	Left	Thru	Right	App. Total	Left	Thru	Right	App. Total		
Peak Hour Analysis From 06:00 AM to 08:45 AM - Peak 1 of 1																		
Peak Hour for Entire Intersection Begins at 07:45 AM																		
07:45 AM	123	0	14	137	0	127	7	134	0	0	0	0	43	78	0	121	392	
08:00 AM	121	0	12	133	0	90	9	99	0	0	0	0	71	96	0	167	399	
08:15 AM	118	0	11	129	0	83	8	91	0	0	0	0	33	34	0	67	287	
08:30 AM	116	0	11	127	0	70	15	85	0	0	0	0	26	34	0	60	272	
Total Volume	478	0	48	526	0	370	39	409	0	0	0	0	173	242	0	415	1350	
% App. Total	90.9	0	9.1		0	90.5	9.5		0	0	0		41.7	58.3	0			
PHF	.972	.000	.857	.960	.000	.728	.650	.763	.000	.000	.000	.000	.609	.630	.000	.621	.846	

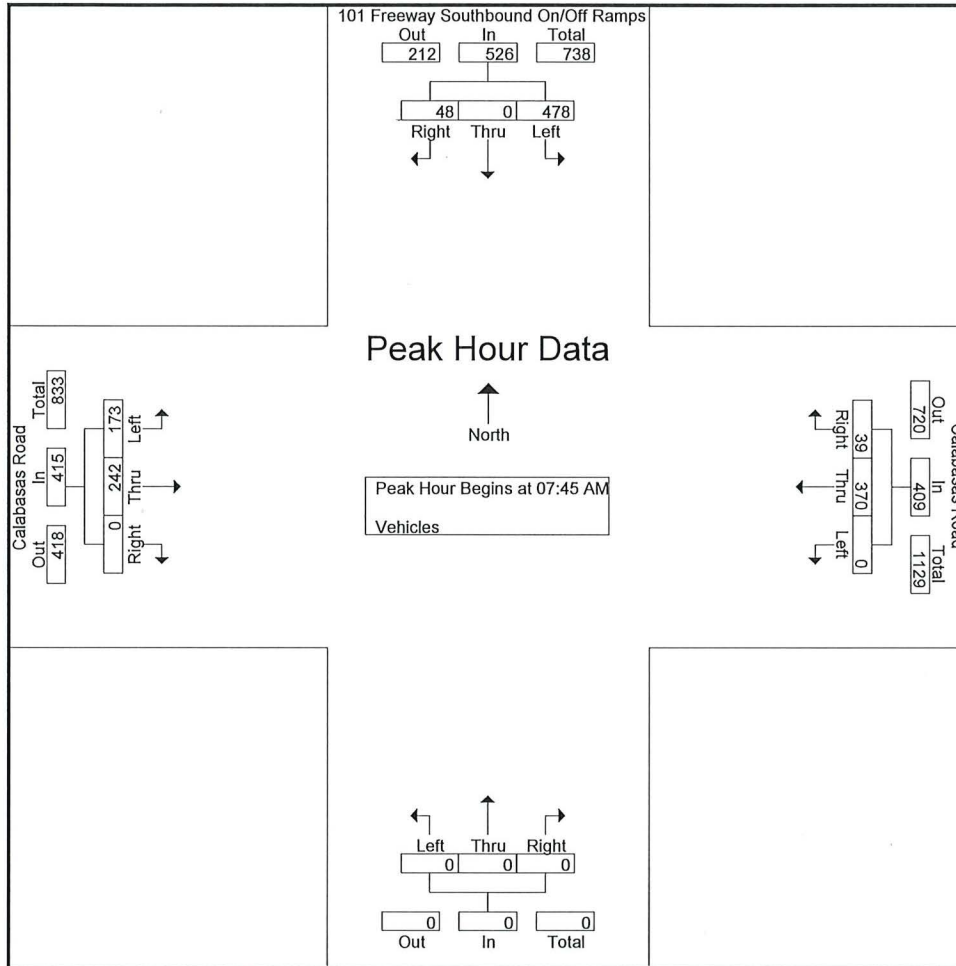

**CITY TRAFFIC COUNTERS**  
**WWW.CTCOUNTERS.COM**

File Name : 101FreewaySBRamps\_CalabasasRd  
 Site Code : 00000000  
 Start Date : 2/1/2023  
 Page No : 3

Start Time	101 Freeway Southbound On/Off Ramps Southbound				Calabasas Road Westbound				Northbound				Calabasas Road Eastbound				Int. Total
	Left	Thru	Right	App. Total	Left	Thru	Right	App. Total	Left	Thru	Right	App. Total	Left	Thru	Right	App. Total	
Peak Hour Analysis From 04:00 PM to 05:45 PM - Peak 1 of 1																	
Peak Hour for Entire Intersection Begins at 04:00 PM																	
04:00 PM	100	0	9	109	0	88	40	128	0	0	0	0	88	86	0	174	411
04:15 PM	140	0	3	143	0	70	29	99	0	0	0	0	63	104	0	167	409
04:30 PM	157	0	5	162	0	82	33	115	0	0	0	0	64	86	0	150	427
04:45 PM	153	0	4	157	0	63	47	110	0	0	0	0	56	83	0	139	406
Total Volume	550	0	21	571	0	303	149	452	0	0	0	0	271	359	0	630	1653
% App. Total	96.3	0	3.7		0	67	33		0	0	0		43	57	0		
PHF	.876	.000	.583	.881	.000	.861	.793	.883	.000	.000	.000	.000	.770	.863	.000	.905	.968

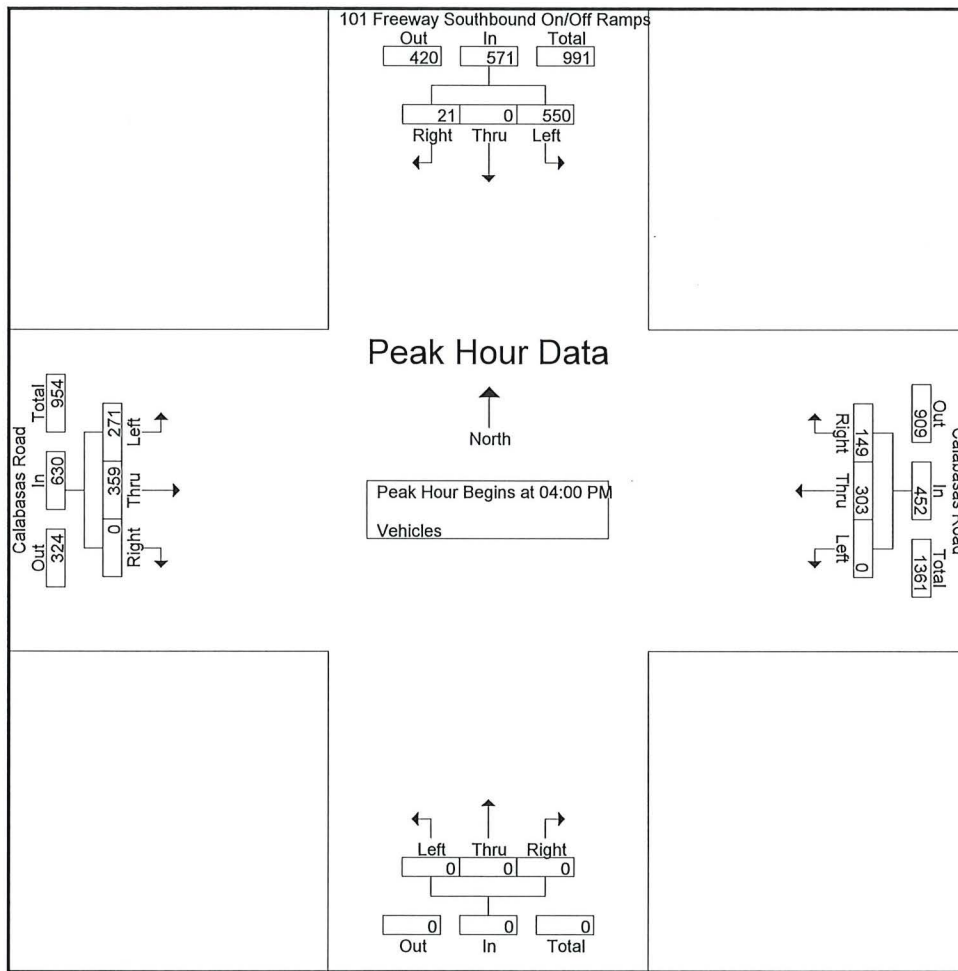

**CITY TRAFFIC COUNTERS**  
**WWW.CTCOUNTERS.COM**

File Name : ParkwayCalabasas\_CalabasasRd  
 Site Code : 00000000  
 Start Date : 2/1/2023  
 Page No : 1

Groups Printed- Vehicles

Start Time	Parkway Calabasas Southbound			Calabasas Road Westbound			Parkway Calabasas Northbound			Calabasas Road Eastbound			Int. Total
	Left	Thru	Right	Left	Thru	Right	Left	Thru	Right	Left	Thru	Right	
06:00 AM	4	17	15	1	2	8	1	38	0	5	7	8	106
06:15 AM	6	21	24	1	8	10	0	36	3	3	12	10	134
06:30 AM	12	40	19	4	5	6	1	49	1	7	10	12	166
06:45 AM	13	60	43	3	5	12	2	44	2	5	29	25	243
Total	35	138	101	9	20	36	4	167	6	20	58	55	649
07:00 AM	11	69	46	2	12	17	1	70	0	10	26	24	288
07:15 AM	26	89	39	2	14	18	7	88	3	12	19	25	342
07:30 AM	16	97	83	5	28	28	7	115	0	3	53	84	519
07:45 AM	20	128	99	2	20	51	32	157	5	19	68	93	694
Total	73	383	267	11	74	114	47	430	8	44	166	226	1843
08:00 AM	30	120	60	4	24	50	14	196	8	19	109	98	732
08:15 AM	30	118	45	4	32	54	14	182	7	15	74	56	631
08:30 AM	23	105	51	6	25	45	17	155	6	22	62	72	589
08:45 AM	48	139	62	5	28	34	10	110	4	32	89	65	626
Total	131	482	218	19	109	183	55	643	25	88	334	291	2578
04:00 PM	52	77	67	7	27	84	27	142	7	34	124	65	713
04:15 PM	38	91	50	19	31	66	12	151	9	33	133	72	705
04:30 PM	46	87	73	7	31	91	11	136	3	26	129	61	701
04:45 PM	43	78	66	9	29	75	16	145	15	23	100	70	669
Total	179	333	256	42	118	316	66	574	34	116	486	268	2788
05:00 PM	62	81	93	17	33	107	10	147	6	15	112	67	750
05:15 PM	63	94	73	13	26	92	9	139	5	15	111	65	705
05:30 PM	35	80	84	13	13	87	14	130	8	19	112	68	663
05:45 PM	42	83	72	13	35	90	9	119	6	19	95	60	643
Total	202	338	322	56	107	376	42	535	25	68	430	260	2761
Grand Total	620	1674	1164	137	428	1025	214	2349	98	336	1474	1100	10619
Apprch %	17.9	48.4	33.7	8.6	26.9	64.5	8	88.3	3.7	11.5	50.7	37.8	
Total %	5.8	15.8	11	1.3	4	9.7	2	22.1	0.9	3.2	13.9	10.4	

**CITY TRAFFIC COUNTERS**  
**WWW.CTCOUNTERS.COM**

File Name : ParkwayCalabasas\_CalabasasRd  
 Site Code : 00000000  
 Start Date : 2/1/2023  
 Page No : 2

Start Time	Parkway Calabasas Southbound				Calabasas Road Westbound				Parkway Calabasas Northbound				Calabasas Road Eastbound				Int. Total
	Left	Thru	Right	App. Total	Left	Thru	Right	App. Total	Left	Thru	Right	App. Total	Left	Thru	Right	App. Total	
Peak Hour Analysis From 06:00 AM to 08:45 AM - Peak 1 of 1																	
Peak Hour for Entire Intersection Begins at 07:45 AM																	
07:45 AM	20	128	99	247	2	20	51	73	32	157	5	194	19	68	93	180	694
08:00 AM	30	120	60	210	4	24	50	78	14	196	8	218	19	109	98	226	732
08:15 AM	30	118	45	193	4	32	54	90	14	182	7	203	15	74	56	145	631
08:30 AM	23	105	51	179	6	25	45	76	17	155	6	178	22	62	72	156	589
Total Volume	103	471	255	829	16	101	200	317	77	690	26	793	75	313	319	707	2646
% App. Total	12.4	56.8	30.8		5	31.9	63.1		9.7	87	3.3		10.6	44.3	45.1		
PHF	.858	.920	.644	.839	.667	.789	.926	.881	.602	.880	.813	.909	.852	.718	.814	.782	.904

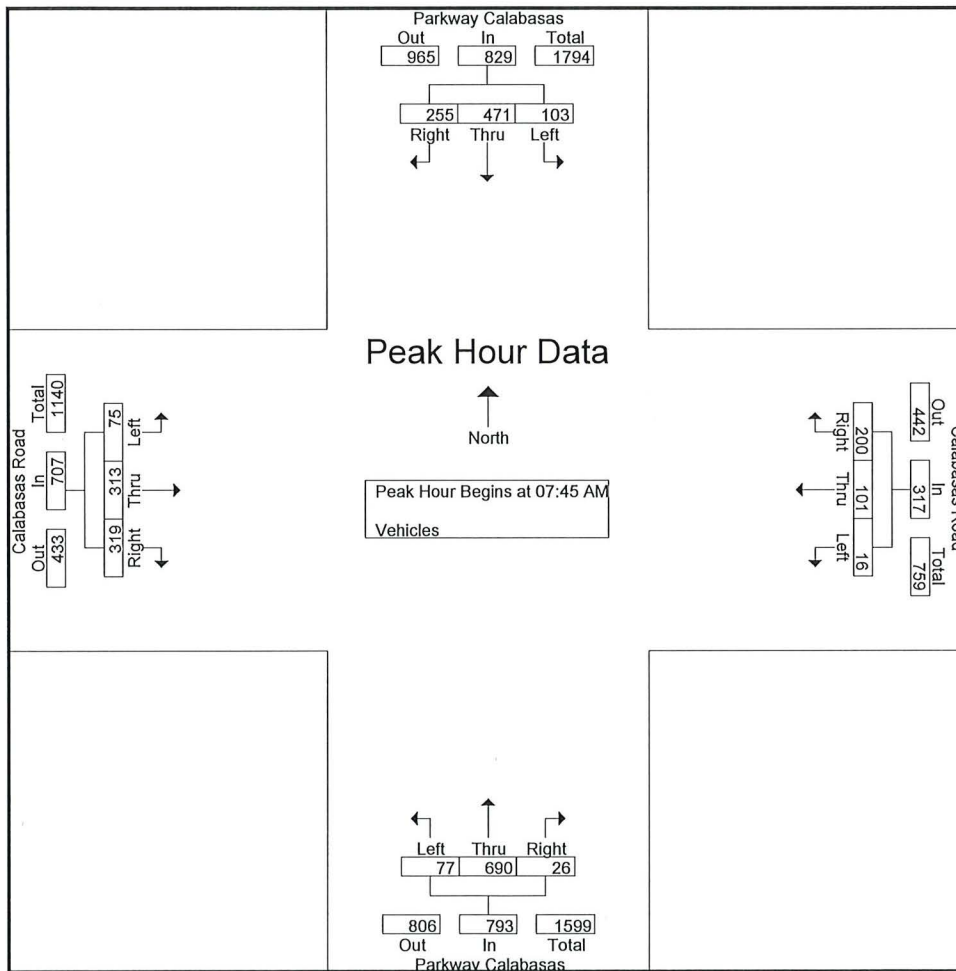

**CITY TRAFFIC COUNTERS**  
**WWW.CTCOUNTERS.COM**

File Name : ParkwayCalabasas\_CalabasasRd  
 Site Code : 00000000  
 Start Date : 2/1/2023  
 Page No : 3

Start Time	Parkway Calabasas Southbound				Calabasas Road Westbound				Parkway Calabasas Northbound				Calabasas Road Eastbound				Int. Total
	Left	Thru	Right	App. Total	Left	Thru	Right	App. Total	Left	Thru	Right	App. Total	Left	Thru	Right	App. Total	
Peak Hour Analysis From 04:00 PM to 05:45 PM - Peak 1 of 1																	
Peak Hour for Entire Intersection Begins at 04:15 PM																	
04:15 PM	38	91	50	179	19	31	66	116	12	151	9	172	33	133	72	238	705
04:30 PM	46	87	73	206	7	31	91	129	11	136	3	150	26	129	61	216	701
04:45 PM	43	78	66	187	9	29	75	113	16	145	15	176	23	100	70	193	669
05:00 PM	62	81	93	236	17	33	107	157	10	147	6	163	15	112	67	194	750
Total Volume	189	337	282	808	52	124	339	515	49	579	33	661	97	474	270	841	2825
% App. Total	23.4	41.7	34.9		10.1	24.1	65.8		7.4	87.6	5		11.5	56.4	32.1		
PHF	.762	.926	.758	.856	.684	.939	.792	.820	.766	.959	.550	.939	.735	.891	.938	.883	.942

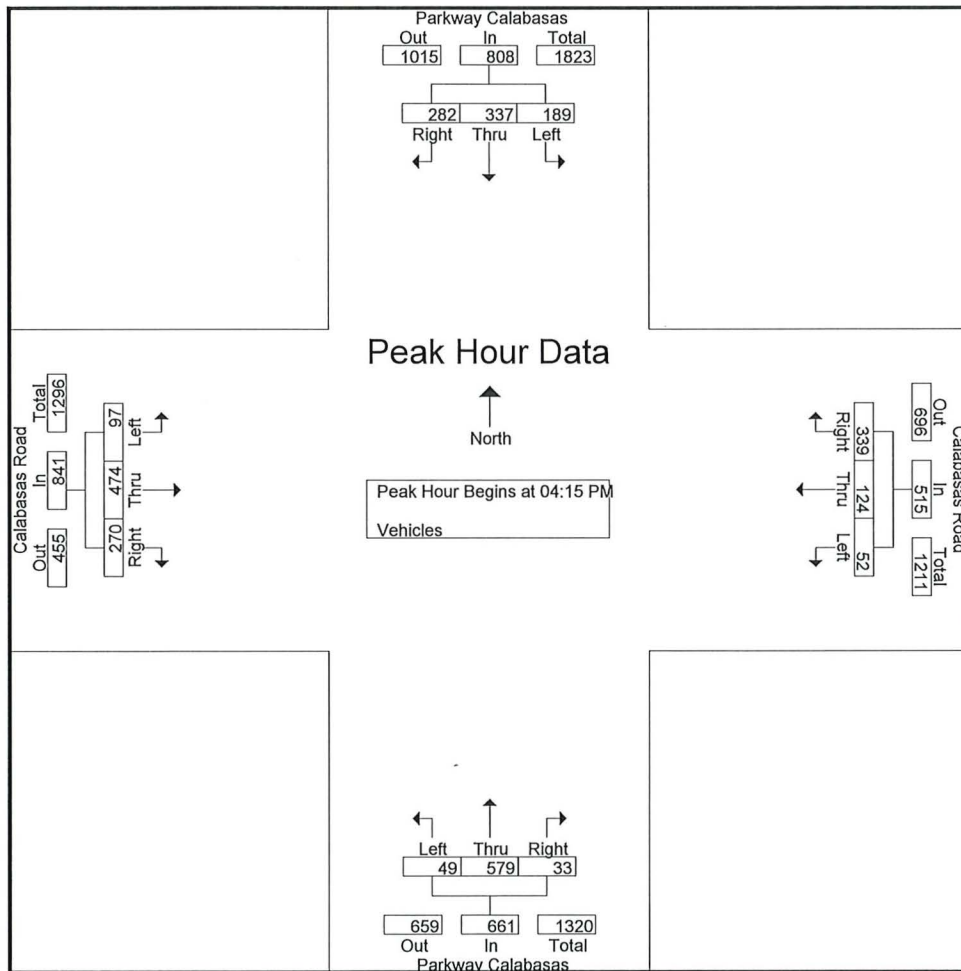

## **INTERSECTION LEVEL OF SERVICE CALCULATIONS**

- Reference 1 - Calabasas Road/Mureau Road
- Reference 2 - U.S. Highway 101 Southbound Ramps/Calabasas Road
- Reference 3 - Calabasas Road/Calabasas Parkway

# HCS7 Two-Way Stop-Control Report

General Information		Site Information	
Analyst	Darryl Nelson	Intersection	Calabaras Road/Mureau Road
Agency/Co.	ATE	Jurisdiction	City of Calabaras
Date Performed	11/1/2023	East/West Street	Calabaras Road
Analysis Year	2023	North/South Street	Mureau Road-Calabaras Road
Time Analyzed	AM Peak Hour	Peak Hour Factor	0.75
Intersection Orientation	North-South	Analysis Time Period (hrs)	0.25
Project Description	Kia of Calabaras		

## Lanes

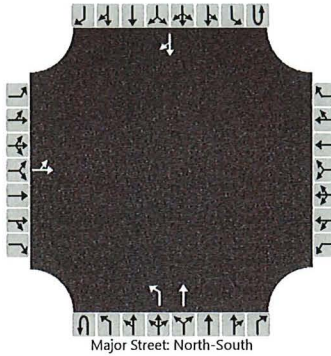

## Vehicle Volumes and Adjustments

Approach	Eastbound				Westbound				Northbound				Southbound				
	U	L	T	R	U	L	T	R	U	L	T	R	U	L	T	R	
Movement																	
Priority		10	11	12		7	8	9	1U	1	2	3	4U	4	5	6	
Number of Lanes		0	1	0		0	0	0	0	1	1	0	0	0	1	0	
Configuration		LT								L	T					TR	
Volume (veh/h)		5	10							22	321				397	5	
Percent Heavy Vehicles (%)		3	3							3							
Proportion Time Blocked																	
Percent Grade (%)		0															
Right Turn Channelized																	
Median Type   Storage		Undivided															

## Critical and Follow-up Headways

Base Critical Headway (sec)		7.1	6.5							4.1						
Critical Headway (sec)		7.13	6.53							4.13						
Base Follow-Up Headway (sec)		3.5	4.0							2.2						
Follow-Up Headway (sec)		3.53	4.03							2.23						

## Delay, Queue Length, and Level of Service

Flow Rate, v (veh/h)		20								29								
Capacity, c (veh/h)		222								1027								
v/c Ratio		0.09								0.03								
95% Queue Length, Q <sub>95</sub> (veh)		0.3								0.1								
Control Delay (s/veh)		22.8								8.6								
Level of Service (LOS)		C								A								
Approach Delay (s/veh)		22.8									0.6							
Approach LOS		C																

# HCS7 Two-Way Stop-Control Report

General Information				Site Information			
Analyst	Darryl Nelson			Intersection	Calabasas Road/Mureau Roa		
Agency/Co.	ATE			Jurisdiction	City of Calabasas		
Date Performed	11/1/2023			East/West Street	Calabasas Road		
Analysis Year	2023			North/South Street	Mureau Road		
Time Analyzed	PM Peak Hour			Peak Hour Factor	0.75		
Intersection Orientation	North-South			Analysis Time Period (hrs)	0.25		
Project Description	Kia of Calabasas						

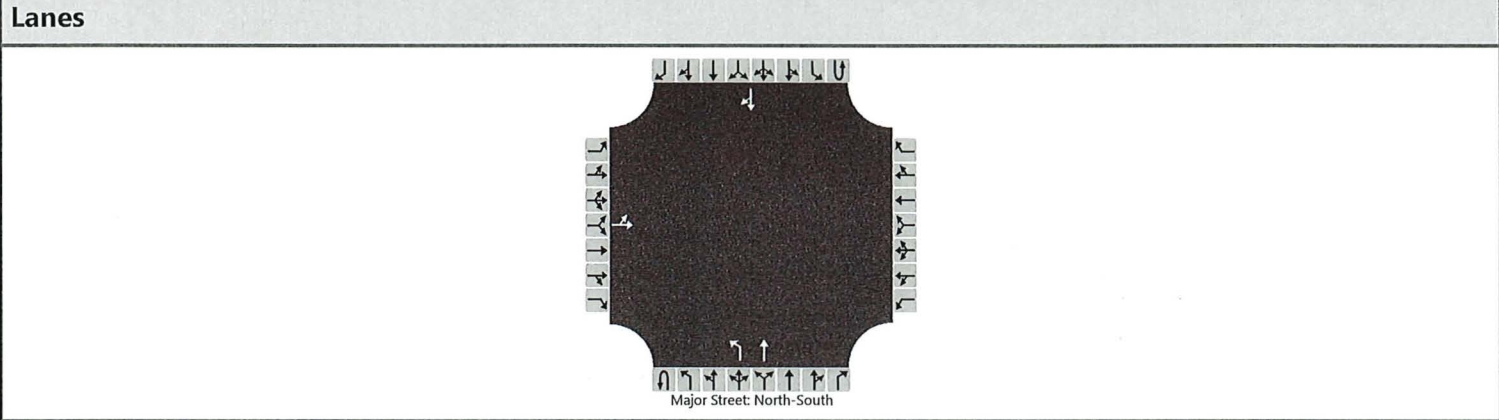

**Vehicle Volumes and Adjustments**

Approach	Eastbound				Westbound				Northbound				Southbound					
	U	L	T	R	U	L	T	R	U	L	T	R	U	L	T	R		
Movement																		
Priority		10	11	12		7	8	9	1U	1	2	3	4U	4	5	6		
Number of Lanes		0	1	0		0	0	0		0	1	1	0		0	0	1	0
Configuration		LT								L	T						TR	
Volume (veh/h)		3	17							5	255					439	0	
Percent Heavy Vehicles (%)		3	3							3								
Proportion Time Blocked																		
Percent Grade (%)	0																	
Right Turn Channelized																		
Median Type   Storage	Undivided																	

**Critical and Follow-up Headways**

Base Critical Headway (sec)		7.1	6.5							4.1							
Critical Headway (sec)		7.13	6.53							4.13							
Base Follow-Up Headway (sec)		3.5	4.0							2.2							
Follow-Up Headway (sec)		3.53	4.03							2.23							

**Delay, Queue Length, and Level of Service**

Flow Rate, v (veh/h)		27								7							
Capacity, c (veh/h)		258								984							
v/c Ratio		0.10								0.01							
95% Queue Length, Q <sub>95</sub> (veh)		0.3								0.0							
Control Delay (s/veh)		20.5								8.7							
Level of Service (LOS)		C								A							
Approach Delay (s/veh)		20.5								0.2							
Approach LOS		C															

# HCS7 Two-Way Stop-Control Report

General Information				Site Information			
Analyst	Darryl Nelson			Intersection	Calabasas Road/Mureau Roa		
Agency/Co.	ATE			Jurisdiction	City of Calabasas		
Date Performed	11/1/2023			East/West Street	Calabasas Road		
Analysis Year	2023 + <i>Project</i>			North/South Street	Mureau Road		
Time Analyzed	AM Peak Hour			Peak Hour Factor	0.75		
Intersection Orientation	North-South			Analysis Time Period (hrs)	0.25		
Project Description	Kia of Calabasas						

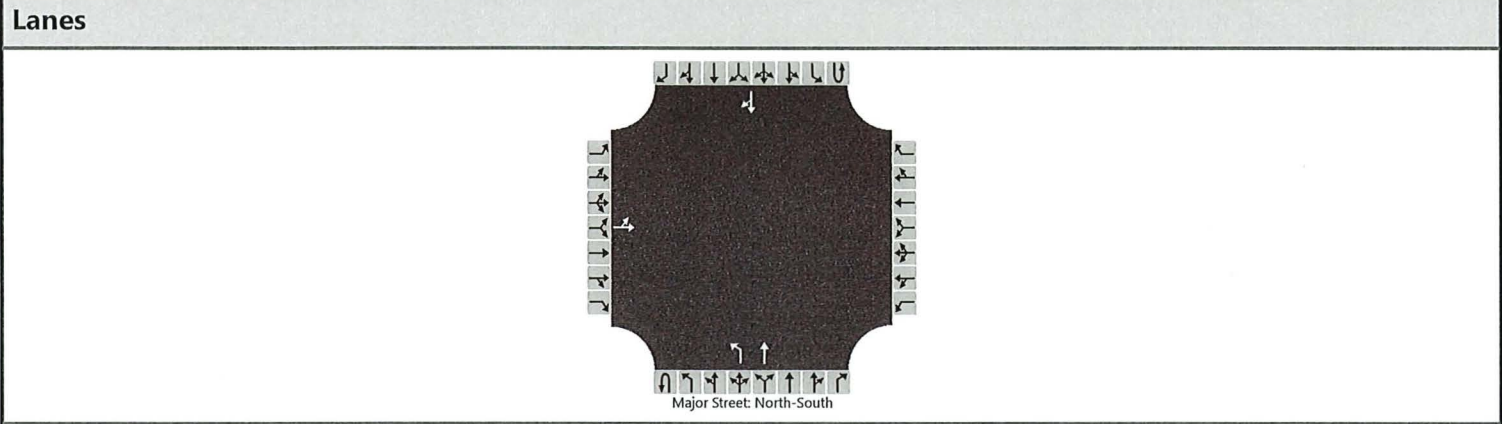

**Vehicle Volumes and Adjustments**

Approach	Eastbound				Westbound				Northbound				Southbound			
	U	L	T	R	U	L	T	R	U	L	T	R	U	L	T	R
Movement																
Priority		10	11	12		7	8	9	1U	1	2	3	4U	4	5	6
Number of Lanes		0	1	0		0	0	0	0	1	1	0	0	0	1	0
Configuration		LT								L	T					TR
Volume (veh/h)		5	10							22	323				403	5
Percent Heavy Vehicles (%)		3	3							3						
Proportion Time Blocked																
Percent Grade (%)	0															
Right Turn Channelized																
Median Type   Storage	Undivided															

**Critical and Follow-up Headways**

Base Critical Headway (sec)		7.1	6.5							4.1						
Critical Headway (sec)		7.13	6.53							4.13						
Base Follow-Up Headway (sec)		3.5	4.0							2.2						
Follow-Up Headway (sec)		3.53	4.03							2.23						

**Delay, Queue Length, and Level of Service**

Flow Rate, v (veh/h)		20								29							
Capacity, c (veh/h)		219								1020							
v/c Ratio		0.09								0.03							
95% Queue Length, Q <sub>95</sub> (veh)		0.3								0.1							
Control Delay (s/veh)		23.1								8.6							
Level of Service (LOS)		C								A							
Approach Delay (s/veh)		23.1								0.6							
Approach LOS		C															

# HCS7 Two-Way Stop-Control Report

General Information		Site Information	
Analyst	Darryl Nelson	Intersection	Calabasas Road/Mureau Roa
Agency/Co.	ATE	Jurisdiction	City of Calabasas
Date Performed	11/1/2023	East/West Street	Calabasas Road
Analysis Year	2023 <i>+ Project</i>	North/South Street	Mureau Road
Time Analyzed	PM Peak Hour	Peak Hour Factor	0.75
Intersection Orientation	North-South	Analysis Time Period (hrs)	0.25
Project Description	Kia of Calabasas		

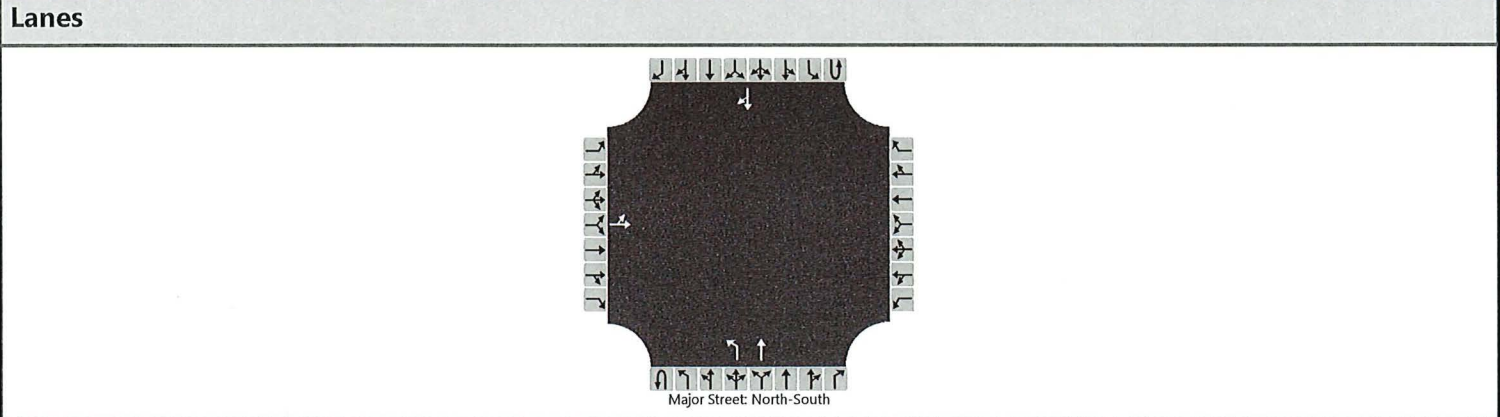

**Vehicle Volumes and Adjustments**

Approach	Eastbound				Westbound				Northbound				Southbound			
	U	L	T	R	U	L	T	R	U	L	T	R	U	L	T	R
Movement																
Priority		10	11	12		7	8	9	1U	1	2	3	4U	4	5	6
Number of Lanes		0	1	0		0	0	0	0	1	1	0	0	0	1	0
Configuration		LT								L	T					TR
Volume (veh/h)		3	17							5	262				444	0
Percent Heavy Vehicles (%)		3	3							3						
Proportion Time Blocked																
Percent Grade (%)	0															
Right Turn Channelized																
Median Type   Storage	Undivided															

**Critical and Follow-up Headways**

Base Critical Headway (sec)		7.1	6.5							4.1						
Critical Headway (sec)		7.13	6.53							4.13						
Base Follow-Up Headway (sec)		3.5	4.0							2.2						
Follow-Up Headway (sec)		3.53	4.03							2.23						

**Delay, Queue Length, and Level of Service**

Flow Rate, v (veh/h)		27								7							
Capacity, c (veh/h)		253								979							
v/c Ratio		0.11								0.01							
95% Queue Length, Q <sub>95</sub> (veh)		0.3								0.0							
Control Delay (s/veh)		20.9								8.7							
Level of Service (LOS)		C								A							
Approach Delay (s/veh)		20.9								0.2							
Approach LOS		C															

Intersection				
Intersection Delay, s/veh	3.8			
Intersection LOS	A			
Approach	EB	WB	SB	
Entry Lanes	1	1	1	
Conflicting Circle Lanes	1	1	1	
Adj Approach Flow, veh/h	20	460	544	
Demand Flow Rate, veh/h	20	470	555	
Vehicles Circulating, veh/h	548	7	30	
Vehicles Exiting, veh/h	37	561	7	
Ped Vol Crossing Leg, #/h	0	0	0	
Ped Cap Adj	1.000	1.000	1.000	
Approach Delay, s/veh	4.9	0.2	6.7	
Approach LOS	A	A	A	
Lane	Left	Left	Bypass	Left
Designated Moves	LT	T	R	LR
Assumed Moves	LT	T	R	LR
RT Channelized			Free	
Lane Util	1.000	1.000		1.000
Follow-Up Headway, s	2.609	2.609		2.609
Critical Headway, s	4.976	4.976	440	4.976
Entry Flow, veh/h	20	30	1938	555
Cap Entry Lane, veh/h	789	1370	0.980	1338
Entry HV Adj Factor	0.987	0.980	431	0.980
Flow Entry, veh/h	20	29	1900	544
Cap Entry, veh/h	779	1343	0.227	1312
V/C Ratio	0.025	0.022	0.0	0.415
Control Delay, s/veh	4.9	2.8	A	6.7
LOS	A	A	1	A
95th %tile Queue, veh	0	0		2

Intersection				
Intersection Delay, s/veh	3.9			
Intersection LOS	A			
Approach	EB	WB	SB	
Entry Lanes	1	1	1	
Conflicting Circle Lanes	1	1	1	
Adj Approach Flow, veh/h	22	300	499	
Demand Flow Rate, veh/h	22	306	509	
Vehicles Circulating, veh/h	509	3	6	
Vehicles Exiting, veh/h	6	528	3	
Ped Vol Crossing Leg, #/h	0	0	0	
Ped Cap Adj	1.000	1.000	1.000	
Approach Delay, s/veh	4.7	0.1	6.1	
Approach LOS	A	A	A	
Lane	Left	Left	Bypass	Left
Designated Moves	LT	T	R	LR
Assumed Moves	LT	T	R	LR
RT Channelized			Free	
Lane Util	1.000	1.000		1.000
Follow-Up Headway, s	2.609	2.609		2.609
Critical Headway, s	4.976	4.976	300	4.976
Entry Flow, veh/h	22	6	1938	509
Cap Entry Lane, veh/h	821	1376	0.980	1371
Entry HV Adj Factor	0.983	0.980	294	0.980
Flow Entry, veh/h	22	6	1900	499
Cap Entry, veh/h	807	1349	0.155	1344
V/C Ratio	0.027	0.004	0.0	0.371
Control Delay, s/veh	4.7	2.7	A	6.1
LOS	A	A	1	A
95th %tile Queue, veh	0	0		2

HCM 6th Roundabout  
 4: Calabasas Road & Mureau Road

11/01/2023

Intersection			
Intersection Delay, s/veh	7.4		
Intersection LOS	A		
Approach	EB	WB	SB
Entry Lanes	1	1	1
Conflicting Circle Lanes	1	1	1
Adj Approach Flow, veh/h	44	564	595
Demand Flow Rate, veh/h	45	575	606
Vehicles Circulating, veh/h	582	12	98
Vehicles Exiting, veh/h	122	615	489
Ped Vol Crossing Leg, #/h	0	0	0
Ped Cap Adj	1.000	1.000	1.000
Approach Delay, s/veh	5.4	6.8	8.1
Approach LOS	A	A	A
Lane	Left	Left	Left
Designated Moves	LT	TR	LR
Assumed Moves	LT	TR	LR
RT Channelized			
Lane Util	1.000	1.000	1.000
Follow-Up Headway, s	2.609	2.609	2.609
Critical Headway, s	4.976	4.976	4.976
Entry Flow, veh/h	45	575	606
Cap Entry Lane, veh/h	762	1363	1249
Entry HV Adj Factor	0.986	0.981	0.982
Flow Entry, veh/h	44	564	595
Cap Entry, veh/h	751	1337	1226
V/C Ratio	0.059	0.422	0.485
Control Delay, s/veh	5.4	6.8	8.1
LOS	A	A	A
95th %tile Queue, veh	0	2	3

Intersection			
Intersection Delay, s/veh	6.1		
Intersection LOS	A		
Approach	EB	WB	SB
Entry Lanes	1	1	1
Conflicting Circle Lanes	1	1	1
Adj Approach Flow, veh/h	102	369	547
Demand Flow Rate, veh/h	104	377	558
Vehicles Circulating, veh/h	551	20	35
Vehicles Exiting, veh/h	42	635	362
Ped Vol Crossing Leg, #/h	0	0	0
Ped Cap Adj	1.000	1.000	1.000
Approach Delay, s/veh	6.0	5.2	6.8
Approach LOS	A	A	A
Lane	Left	Left	Left
Designated Moves	LT	TR	LR
Assumed Moves	LT	TR	LR
RT Channelized			
Lane Util	1.000	1.000	1.000
Follow-Up Headway, s	2.609	2.609	2.609
Critical Headway, s	4.976	4.976	4.976
Entry Flow, veh/h	104	377	558
Cap Entry Lane, veh/h	787	1352	1331
Entry HV Adj Factor	0.984	0.980	0.980
Flow Entry, veh/h	102	369	547
Cap Entry, veh/h	774	1324	1305
V/C Ratio	0.132	0.279	0.419
Control Delay, s/veh	6.0	5.2	6.8
LOS	A	A	A
95th %tile Queue, veh	0	1	2

Intersection			
Intersection Delay, s/veh	7.4		
Intersection LOS	A		
Approach	EB	WB	SB
Entry Lanes	1	1	1
Conflicting Circle Lanes	1	1	1
Adj Approach Flow, veh/h	44	567	603
Demand Flow Rate, veh/h	45	578	615
Vehicles Circulating, veh/h	591	12	98
Vehicles Exiting, veh/h	122	624	492
Ped Vol Crossing Leg, #/h	0	0	0
Ped Cap Adj	1.000	1.000	1.000
Approach Delay, s/veh	5.4	6.8	8.2
Approach LOS	A	A	A
Lane	Left	Left	Left
Designated Moves	LT	TR	LR
Assumed Moves	LT	TR	LR
RT Channelized			
Lane Util	1.000	1.000	1.000
Follow-Up Headway, s	2.609	2.609	2.609
Critical Headway, s	4.976	4.976	4.976
Entry Flow, veh/h	45	578	615
Cap Entry Lane, veh/h	755	1363	1249
Entry HV Adj Factor	0.986	0.981	0.980
Flow Entry, veh/h	44	567	603
Cap Entry, veh/h	744	1337	1224
V/C Ratio	0.060	0.424	0.493
Control Delay, s/veh	5.4	6.8	8.2
LOS	A	A	A
95th %tile Queue, veh	0	2	3

Intersection			
Intersection Delay, s/veh	6.2		
Intersection LOS	A		
Approach	EB	WB	SB
Entry Lanes	1	1	1
Conflicting Circle Lanes	1	1	1
Adj Approach Flow, veh/h	102	377	553
Demand Flow Rate, veh/h	104	385	564
Vehicles Circulating, veh/h	557	20	35
Vehicles Exiting, veh/h	42	641	370
Ped Vol Crossing Leg, #/h	0	0	0
Ped Cap Adj	1.000	1.000	1.000
Approach Delay, s/veh	6.1	5.2	6.9
Approach LOS	A	A	A
Lane	Left	Left	Left
Designated Moves	LT	TR	LR
Assumed Moves	LT	TR	LR
RT Channelized			
Lane Util	1.000	1.000	1.000
Follow-Up Headway, s	2.609	2.609	2.609
Critical Headway, s	4.976	4.976	4.976
Entry Flow, veh/h	104	385	564
Cap Entry Lane, veh/h	782	1352	1331
Entry HV Adj Factor	0.984	0.980	0.980
Flow Entry, veh/h	102	377	553
Cap Entry, veh/h	769	1325	1305
V/C Ratio	0.133	0.285	0.424
Control Delay, s/veh	6.1	5.2	6.9
LOS	A	A	A
95th %tile Queue, veh	0	1	2

HCM 6th Signalized Intersection Summary  
 8: Calabasas Road & U.S. Highway 101 Ramps

11/01/2023



Movement	EBL	EBT	WBT	WBR	SBL	SBR
Lane Configurations						
Traffic Volume (veh/h)	173	242	370	39	478	48
Future Volume (veh/h)	173	242	370	39	478	48
Initial Q (Qb), veh	0	0	0	0	0	0
Ped-Bike Adj(A_pbT)	1.00			1.00	1.00	1.00
Parking Bus, Adj	1.00	1.00	1.00	1.00	1.00	1.00
Work Zone On Approach		No	No		No	
Adj Sat Flow, veh/h/ln	1870	1870	1870	1870	1870	1870
Adj Flow Rate, veh/h	204	285	435	0	562	0
Peak Hour Factor	0.85	0.85	0.85	0.85	0.85	0.85
Percent Heavy Veh, %	2	2	2	2	2	2
Cap, veh/h	318	866	866		1510	
Arrive On Green	0.46	0.46	0.15	0.00	0.44	0.00
Sat Flow, veh/h	954	1870	1870	1585	3456	1585
Grp Volume(v), veh/h	204	285	435	0	562	0
Grp Sat Flow(s),veh/h/ln	954	1870	1870	1585	1728	1585
Q Serve(g_s), s	18.4	8.7	19.2	0.0	9.8	0.0
Cycle Q Clear(g_c), s	37.6	8.7	19.2	0.0	9.8	0.0
Prop In Lane	1.00			1.00	1.00	1.00
Lane Grp Cap(c), veh/h	318	866	866		1510	
V/C Ratio(X)	0.64	0.33	0.50		0.37	
Avail Cap(c_a), veh/h	412	1049	1049		1510	
HCM Platoon Ratio	1.00	1.00	0.33	0.33	1.00	1.00
Upstream Filter(I)	1.00	1.00	0.94	0.00	1.00	0.00
Uniform Delay (d), s/veh	32.2	15.3	28.6	0.0	17.0	0.0
Incr Delay (d2), s/veh	2.2	0.2	0.4	0.0	0.7	0.0
Initial Q Delay(d3),s/veh	0.0	0.0	0.0	0.0	0.0	0.0
%ile BackOfQ(50%),veh/ln	4.3	3.6	9.6	0.0	3.9	0.0
Unsig. Movement Delay, s/veh						
LnGrp Delay(d),s/veh	34.4	15.5	29.0	0.0	17.7	0.0
LnGrp LOS	C	B	C		B	
Approach Vol, veh/h		489	435		562	
Approach Delay, s/veh		23.4	29.0		17.7	
Approach LOS		C	C		B	
Timer - Assigned Phs				4	6	8
Phs Duration (G+Y+Rc), s				46.2	43.8	46.2
Change Period (Y+Rc), s				4.5	4.5	4.5
Max Green Setting (Gmax), s				50.5	30.5	50.5
Max Q Clear Time (g_c+I1), s				39.6	11.8	21.2
Green Ext Time (p_c), s				2.1	2.0	2.9

Intersection Summary	
HCM 6th Ctrl Delay	22.9
HCM 6th LOS	C

Notes  
 Unsignalized Delay for [WBR, SBR] is excluded from calculations of the approach delay and intersection delay.

HCM 6th Signalized Intersection Summary  
 8: Calabasas Road & U.S. Highway 101 Ramps

11/01/2023



Movement	EBL	EBT	WBT	WBR	SBL	SBR
Lane Configurations						
Traffic Volume (veh/h)	271	359	303	149	550	21
Future Volume (veh/h)	271	359	303	149	550	21
Initial Q (Qb), veh	0	0	0	0	0	0
Ped-Bike Adj(A_pbT)	1.00			1.00	1.00	1.00
Parking Bus, Adj	1.00	1.00	1.00	1.00	1.00	1.00
Work Zone On Approach		No	No		No	
Adj Sat Flow, veh/h/ln	1870	1870	1870	1870	1870	1870
Adj Flow Rate, veh/h	282	374	316	0	573	0
Peak Hour Factor	0.96	0.96	0.96	0.96	0.96	0.96
Percent Heavy Veh, %	2	2	2	2	2	2
Cap, veh/h	406	857	857		1526	
Arrive On Green	0.46	0.46	0.15	0.00	0.44	0.00
Sat Flow, veh/h	1064	1870	1870	1585	3456	1585
Grp Volume(v), veh/h	282	374	316	0	573	0
Grp Sat Flow(s),veh/h/ln	1064	1870	1870	1585	1728	1585
Q Serve(g_s), s	22.5	12.2	13.7	0.0	10.0	0.0
Cycle Q Clear(g_c), s	36.2	12.2	13.7	0.0	10.0	0.0
Prop In Lane	1.00			1.00	1.00	1.00
Lane Grp Cap(c), veh/h	406	857	857		1526	
V/C Ratio(X)	0.69	0.44	0.37		0.38	
Avail Cap(c_a), veh/h	527	1070	1070		1526	
HCM Platoon Ratio	1.00	1.00	0.33	0.33	1.00	1.00
Upstream Filter(l)	1.00	1.00	0.93	0.00	1.00	0.00
Uniform Delay (d), s/veh	29.5	16.5	26.5	0.0	16.8	0.0
Incr Delay (d2), s/veh	2.7	0.4	0.2	0.0	0.7	0.0
Initial Q Delay(d3),s/veh	0.0	0.0	0.0	0.0	0.0	0.0
%ile BackOfQ(50%),veh/ln	5.8	5.1	6.8	0.0	4.0	0.0
Unsig. Movement Delay, s/veh						
LnGrp Delay(d),s/veh	32.1	16.9	26.7	0.0	17.5	0.0
LnGrp LOS	C	B	C		B	
Approach Vol, veh/h		656	316		573	
Approach Delay, s/veh		23.4	26.7		17.5	
Approach LOS		C	C		B	
Timer - Assigned Phs				4	6	8
Phs Duration (G+Y+Rc), s				45.7	44.3	45.7
Change Period (Y+Rc), s				4.5	4.5	4.5
Max Green Setting (Gmax), s				51.5	29.5	51.5
Max Q Clear Time (g_c+I1), s				38.2	12.0	15.7
Green Ext Time (p_c), s				3.1	2.0	2.0
<b>Intersection Summary</b>						
HCM 6th Ctrl Delay			21.9			
HCM 6th LOS			C			

Notes

Unsignalized Delay for [WBR, SBR] is excluded from calculations of the approach delay and intersection delay.

HCM 6th Signalized Intersection Summary  
 8: Calabasas Road & U.S. Highway 101 Ramps

11/01/2023



Movement	EBL	EBT	WBT	WBR	SBL	SBR
Lane Configurations						
Traffic Volume (veh/h)	181	256	402	39	478	75
Future Volume (veh/h)	181	256	402	39	478	75
Initial Q (Qb), veh	0	0	0	0	0	0
Ped-Bike Adj(A_pbT)	1.00			1.00	1.00	1.00
Parking Bus, Adj	1.00	1.00	1.00	1.00	1.00	1.00
Work Zone On Approach		No	No		No	
Adj Sat Flow, veh/h/ln	1870	1870	1870	1870	1870	1870
Adj Flow Rate, veh/h	213	301	473	0	562	0
Peak Hour Factor	0.85	0.85	0.85	0.85	0.85	0.85
Percent Heavy Veh, %	2	2	2	2	2	2
Cap, veh/h	324	928	928		1395	
Arrive On Green	0.50	0.50	0.16	0.00	0.40	0.00
Sat Flow, veh/h	921	1870	1870	1585	3456	1585
Grp Volume(v), veh/h	213	301	473	0	562	0
Grp Sat Flow(s),veh/h/ln	921	1870	1870	1585	1728	1585
Q Serve(g_s), s	19.9	8.7	20.8	0.0	10.4	0.0
Cycle Q Clear(g_c), s	40.7	8.7	20.8	0.0	10.4	0.0
Prop In Lane	1.00			1.00	1.00	1.00
Lane Grp Cap(c), veh/h	324	928	928		1395	
V/C Ratio(X)	0.66	0.32	0.51		0.40	
Avail Cap(c_a), veh/h	394	1070	1070		1395	
HCM Platoon Ratio	1.00	1.00	0.33	0.33	1.00	1.00
Upstream Filter(I)	1.00	1.00	0.93	0.00	1.00	0.00
Uniform Delay (d), s/veh	31.6	13.6	27.6	0.0	19.1	0.0
Incr Delay (d2), s/veh	2.9	0.2	0.4	0.0	0.9	0.0
Initial Q Delay(d3),s/veh	0.0	0.0	0.0	0.0	0.0	0.0
%ile BackOfQ(50%),veh/ln	4.6	3.5	10.4	0.0	4.2	0.0
Unsig. Movement Delay, s/veh						
LnGrp Delay(d),s/veh	34.5	13.8	28.0	0.0	20.0	0.0
LnGrp LOS	C	B	C		B	
Approach Vol, veh/h		514	473		562	
Approach Delay, s/veh		22.4	28.0		20.0	
Approach LOS		C	C		B	
Timer - Assigned Phs				4	6	8
Phs Duration (G+Y+Rc), s				49.2	40.8	49.2
Change Period (Y+Rc), s				4.5	4.5	4.5
Max Green Setting (Gmax), s				51.5	29.5	51.5
Max Q Clear Time (g_c+I1), s				42.7	12.4	22.8
Green Ext Time (p_c), s				2.0	2.0	3.2
<b>Intersection Summary</b>						
HCM 6th Ctrl Delay			23.2			
HCM 6th LOS			C			

Notes

Unsignalized Delay for [WBR, SBR] is excluded from calculations of the approach delay and intersection delay.

HCM 6th Signalized Intersection Summary  
 8: Calabasas Road & U.S. Highway 101 Ramps

11/01/2023



Movement	EBL	EBT	WBT	WBR	SBL	SBR
Lane Configurations						
Traffic Volume (veh/h)	295	398	326	149	550	39
Future Volume (veh/h)	295	398	326	149	550	39
Initial Q (Qb), veh	0	0	0	0	0	0
Ped-Bike Adj(A_pbT)	1.00			1.00	1.00	1.00
Parking Bus, Adj	1.00	1.00	1.00	1.00	1.00	1.00
Work Zone On Approach		No	No		No	
Adj Sat Flow, veh/h/ln	1870	1870	1870	1870	1870	1870
Adj Flow Rate, veh/h	307	415	340	0	573	0
Peak Hour Factor	0.96	0.96	0.96	0.96	0.96	0.96
Percent Heavy Veh, %	2	2	2	2	2	2
Cap, veh/h	430	932	932		1389	
Arrive On Green	0.50	0.50	0.16	0.00	0.40	0.00
Sat Flow, veh/h	1040	1870	1870	1585	3456	1585
Grp Volume(v), veh/h	307	415	340	0	573	0
Grp Sat Flow(s),veh/h/ln	1040	1870	1870	1585	1728	1585
Q Serve(g_s), s	25.0	12.9	14.5	0.0	10.7	0.0
Cycle Q Clear(g_c), s	39.5	12.9	14.5	0.0	10.7	0.0
Prop In Lane	1.00			1.00	1.00	1.00
Lane Grp Cap(c), veh/h	430	932	932		1389	
V/C Ratio(X)	0.71	0.45	0.36		0.41	
Avail Cap(c_a), veh/h	530	1112	1112		1389	
HCM Platoon Ratio	1.00	1.00	0.33	0.33	1.00	1.00
Upstream Filter(I)	1.00	1.00	0.92	0.00	1.00	0.00
Uniform Delay (d), s/veh	28.1	14.6	25.0	0.0	19.3	0.0
Incr Delay (d2), s/veh	3.5	0.3	0.2	0.0	0.9	0.0
Initial Q Delay(d3),s/veh	0.0	0.0	0.0	0.0	0.0	0.0
%ile BackOfQ(50%),veh/ln	6.4	5.2	7.3	0.0	4.3	0.0
Unsig. Movement Delay, s/veh						
LnGrp Delay(d),s/veh	31.6	14.9	25.2	0.0	20.2	0.0
LnGrp LOS	C	B	C		C	
Approach Vol, veh/h		722	340		573	
Approach Delay, s/veh		22.0	25.2		20.2	
Approach LOS		C	C		C	
Timer - Assigned Phs				4	6	8
Phs Duration (G+Y+Rc), s				49.3	40.7	49.3
Change Period (Y+Rc), s				4.5	4.5	4.5
Max Green Setting (Gmax), s				53.5	27.5	53.5
Max Q Clear Time (g_c+I1), s				41.5	12.7	16.5
Green Ext Time (p_c), s				3.3	1.9	2.2
<b>Intersection Summary</b>						
HCM 6th Ctrl Delay			22.0			
HCM 6th LOS			C			

Notes

Unsignalized Delay for [WBR, SBR] is excluded from calculations of the approach delay and intersection delay.

HCM 6th Signalized Intersection Summary  
 8: Calabasas Road & U.S. Highway 101 Ramps

11/01/2023



Movement	EBL	EBT	WBT	WBR	SBL	SBR
Lane Configurations						
Traffic Volume (veh/h)	214	256	415	65	499	72
Future Volume (veh/h)	214	256	415	65	499	72
Initial Q (Qb), veh	0	0	0	0	0	0
Ped-Bike Adj(A_pbT)	1.00			1.00	1.00	1.00
Parking Bus, Adj	1.00	1.00	1.00	1.00	1.00	1.00
Work Zone On Approach		No	No		No	
Adj Sat Flow, veh/h/ln	1870	1870	1870	1870	1870	1870
Adj Flow Rate, veh/h	252	301	488	0	587	0
Peak Hour Factor	0.85	0.85	0.85	0.85	0.85	0.85
Percent Heavy Veh, %	2	2	2	2	2	2
Cap, veh/h	360	1014	1014		1236	
Arrive On Green	0.54	0.54	0.18	0.00	0.36	0.00
Sat Flow, veh/h	908	1870	1870	1585	3456	1585
Grp Volume(v), veh/h	252	301	488	0	587	0
Grp Sat Flow(s),veh/h/ln	908	1870	1870	1585	1728	1585
Q Serve(g_s), s	23.9	7.9	21.1	0.0	11.8	0.0
Cycle Q Clear(g_c), s	45.0	7.9	21.1	0.0	11.8	0.0
Prop In Lane	1.00			1.00	1.00	1.00
Lane Grp Cap(c), veh/h	360	1014	1014		1236	
V/C Ratio(X)	0.70	0.30	0.48		0.47	
Avail Cap(c_a), veh/h	407	1112	1112		1236	
HCM Platoon Ratio	1.00	1.00	0.33	0.33	1.00	1.00
Upstream Filter(l)	1.00	1.00	0.91	0.00	1.00	0.00
Uniform Delay (d), s/veh	29.8	11.2	25.6	0.0	22.4	0.0
Incr Delay (d2), s/veh	4.6	0.2	0.3	0.0	1.3	0.0
Initial Q Delay(d3),s/veh	0.0	0.0	0.0	0.0	0.0	0.0
%ile BackOfQ(50%),veh/ln	5.5	3.1	10.6	0.0	4.9	0.0
Unsig. Movement Delay, s/veh						
LnGrp Delay(d),s/veh	34.4	11.4	25.9	0.0	23.7	0.0
LnGrp LOS	C	B	C		C	
Approach Vol, veh/h		553	488		587	
Approach Delay, s/veh		21.9	25.9		23.7	
Approach LOS		C	C		C	
Timer - Assigned Phs				4	6	8
Phs Duration (G+Y+Rc), s				53.3	36.7	53.3
Change Period (Y+Rc), s				4.5	4.5	4.5
Max Green Setting (Gmax), s				53.5	27.5	53.5
Max Q Clear Time (g_c+I1), s				47.0	13.8	23.1
Green Ext Time (p_c), s				1.8	1.9	3.4
<b>Intersection Summary</b>						
HCM 6th Ctrl Delay			23.7			
HCM 6th LOS			C			

Notes

Unsignalized Delay for [WBR, SBR] is excluded from calculations of the approach delay and intersection delay.

HCM 6th Signalized Intersection Summary  
 8: Calabasas Road & U.S. Highway 101 Ramps

11/01/2023



Movement	EBL	EBT	WBT	WBR	SBL	SBR
Lane Configurations						
Traffic Volume (veh/h)	348	396	328	163	588	39
Future Volume (veh/h)	348	396	328	163	588	39
Initial Q (Qb), veh	0	0	0	0	0	0
Ped-Bike Adj(A_pbT)	1.00			1.00	1.00	1.00
Parking Bus, Adj	1.00	1.00	1.00	1.00	1.00	1.00
Work Zone On Approach		No	No		No	
Adj Sat Flow, veh/h/ln	1870	1870	1870	1870	1870	1870
Adj Flow Rate, veh/h	362	412	342	0	612	0
Peak Hour Factor	0.96	0.96	0.96	0.96	0.96	0.96
Percent Heavy Veh, %	2	2	2	2	2	2
Cap, veh/h	479	1017	1017		1232	
Arrive On Green	0.54	0.54	0.18	0.00	0.36	0.00
Sat Flow, veh/h	1039	1870	1870	1585	3456	1585
Grp Volume(v), veh/h	362	412	342	0	612	0
Grp Sat Flow(s), veh/h/ln	1039	1870	1870	1585	1728	1585
Q Serve(g_s), s	29.7	11.6	14.4	0.0	12.5	0.0
Cycle Q Clear(g_c), s	44.0	11.6	14.4	0.0	12.5	0.0
Prop In Lane	1.00			1.00	1.00	1.00
Lane Grp Cap(c), veh/h	479	1017	1017		1232	
V/C Ratio(X)	0.76	0.41	0.34		0.50	
Avail Cap(c_a), veh/h	543	1133	1133		1232	
HCM Platoon Ratio	1.00	1.00	0.33	0.33	1.00	1.00
Upstream Filter(l)	1.00	1.00	0.90	0.00	1.00	0.00
Uniform Delay (d), s/veh	26.2	12.0	22.8	0.0	22.6	0.0
Incr Delay (d2), s/veh	5.3	0.3	0.2	0.0	1.4	0.0
Initial Q Delay(d3),s/veh	0.0	0.0	0.0	0.0	0.0	0.0
%ile BackOfQ(50%),veh/ln	7.7	4.6	7.2	0.0	5.2	0.0
Unsig. Movement Delay, s/veh						
LnGrp Delay(d),s/veh	31.5	12.3	22.9	0.0	24.1	0.0
LnGrp LOS	C	B	C		C	
Approach Vol, veh/h		774	342		612	
Approach Delay, s/veh		21.3	22.9		24.1	
Approach LOS		C	C		C	
Timer - Assigned Phs				4	6	8
Phs Duration (G+Y+Rc), s				53.4	36.6	53.4
Change Period (Y+Rc), s				4.5	4.5	4.5
Max Green Setting (Gmax), s				54.5	26.5	54.5
Max Q Clear Time (g_c+I1), s				46.0	14.5	16.4
Green Ext Time (p_c), s				2.9	1.9	2.3
<b>Intersection Summary</b>						
HCM 6th Ctrl Delay			22.6			
HCM 6th LOS			C			

Notes

Unsignalized Delay for [WBR, SBR] is excluded from calculations of the approach delay and intersection delay.

HCM 6th Signalized Intersection Summary  
 8: Calabasas Road & U.S. Highway 101 Ramps

11/01/2023



Movement	EBL	EBT	WBT	WBR	SBL	SBR
Lane Configurations						
Traffic Volume (veh/h)	222	270	447	65	499	99
Future Volume (veh/h)	222	270	447	65	499	99
Initial Q (Qb), veh	0	0	0	0	0	0
Ped-Bike Adj(A_pbT)	1.00			1.00	1.00	1.00
Parking Bus, Adj	1.00	1.00	1.00	1.00	1.00	1.00
Work Zone On Approach		No	No		No	
Adj Sat Flow, veh/h/ln	1870	1870	1870	1870	1870	1870
Adj Flow Rate, veh/h	261	318	526	0	587	0
Peak Hour Factor	0.85	0.85	0.85	0.85	0.85	0.85
Percent Heavy Veh, %	2	2	2	2	2	2
Cap, veh/h	367	1082	1082		1111	
Arrive On Green	0.58	0.58	0.19	0.00	0.32	0.00
Sat Flow, veh/h	877	1870	1870	1585	3456	1585
Grp Volume(v), veh/h	261	318	526	0	587	0
Grp Sat Flow(s),veh/h/ln	877	1870	1870	1585	1728	1585
Q Serve(g_s), s	25.6	7.8	22.6	0.0	12.5	0.0
Cycle Q Clear(g_c), s	48.2	7.8	22.6	0.0	12.5	0.0
Prop In Lane	1.00			1.00	1.00	1.00
Lane Grp Cap(c), veh/h	367	1082	1082		1111	
V/C Ratio(X)	0.71	0.29	0.49		0.53	
Avail Cap(c_a), veh/h	411	1174	1174		1111	
HCM Platoon Ratio	1.00	1.00	0.33	0.33	1.00	1.00
Upstream Filter(I)	1.00	1.00	0.90	0.00	1.00	0.00
Uniform Delay (d), s/veh	29.0	9.6	24.5	0.0	25.0	0.0
Incr Delay (d2), s/veh	5.0	0.1	0.3	0.0	1.8	0.0
Initial Q Delay(d3),s/veh	0.0	0.0	0.0	0.0	0.0	0.0
%ile BackOfQ(50%),veh/ln	5.7	3.0	11.3	0.0	5.3	0.0
Unsig. Movement Delay, s/veh						
LnGrp Delay(d),s/veh	33.9	9.8	24.8	0.0	26.8	0.0
LnGrp LOS	C	A	C		C	
Approach Vol, veh/h		579	526		587	
Approach Delay, s/veh		20.7	24.8		26.8	
Approach LOS		C	C		C	
Timer - Assigned Phs				4	6	8
Phs Duration (G+Y+Rc), s				56.6	33.4	56.6
Change Period (Y+Rc), s				4.5	4.5	4.5
Max Green Setting (Gmax), s				56.5	24.5	56.5
Max Q Clear Time (g_c+I1), s				50.2	14.5	24.6
Green Ext Time (p_c), s				1.9	1.7	3.8
<b>Intersection Summary</b>						
HCM 6th Ctrl Delay			24.1			
HCM 6th LOS			C			

Notes

Unsignalized Delay for [WBR, SBR] is excluded from calculations of the approach delay and intersection delay.

HCM 6th Signalized Intersection Summary  
 8: Calabasas Road & U.S. Highway 101 Ramps

11/01/2023



Movement	EBL	EBT	WBT	WBR	SBL	SBR
Lane Configurations						
Traffic Volume (veh/h)	372	435	351	163	588	57
Future Volume (veh/h)	372	435	351	163	588	57
Initial Q (Qb), veh	0	0	0	0	0	0
Ped-Bike Adj(A_pbT)	1.00			1.00	1.00	1.00
Parking Bus, Adj	1.00	1.00	1.00	1.00	1.00	1.00
Work Zone On Approach		No	No		No	
Adj Sat Flow, veh/h/ln	1870	1870	1870	1870	1870	1870
Adj Flow Rate, veh/h	388	453	366	0	612	0
Peak Hour Factor	0.96	0.96	0.96	0.96	0.96	0.96
Percent Heavy Veh, %	2	2	2	2	2	2
Cap, veh/h	501	1091	1091		1095	
Arrive On Green	0.58	0.58	0.19	0.00	0.32	0.00
Sat Flow, veh/h	1016	1870	1870	1585	3456	1585
Grp Volume(v), veh/h	388	453	366	0	612	0
Grp Sat Flow(s),veh/h/ln	1016	1870	1870	1585	1728	1585
Q Serve(g_s), s	32.6	12.0	15.2	0.0	13.2	0.0
Cycle Q Clear(g_c), s	47.8	12.0	15.2	0.0	13.2	0.0
Prop In Lane	1.00			1.00	1.00	1.00
Lane Grp Cap(c), veh/h	501	1091	1091		1095	
V/C Ratio(X)	0.77	0.42	0.34		0.56	
Avail Cap(c_a), veh/h	546	1174	1174		1095	
HCM Platoon Ratio	1.00	1.00	0.33	0.33	1.00	1.00
Upstream Filter(I)	1.00	1.00	0.89	0.00	1.00	0.00
Uniform Delay (d), s/veh	25.0	10.3	21.3	0.0	25.5	0.0
Incr Delay (d2), s/veh	6.3	0.3	0.2	0.0	2.1	0.0
Initial Q Delay(d3),s/veh	0.0	0.0	0.0	0.0	0.0	0.0
%ile BackOfQ(50%),veh/ln	8.3	4.6	7.6	0.0	5.6	0.0
Unsig. Movement Delay, s/veh						
LnGrp Delay(d),s/veh	31.3	10.6	21.4	0.0	27.6	0.0
LnGrp LOS	C	B	C		C	
Approach Vol, veh/h		841	366		612	
Approach Delay, s/veh		20.1	21.4		27.6	
Approach LOS		C	C		C	
Timer - Assigned Phs				4	6	8
Phs Duration (G+Y+Rc), s				57.0	33.0	57.0
Change Period (Y+Rc), s				4.5	4.5	4.5
Max Green Setting (Gmax), s				56.5	24.5	56.5
Max Q Clear Time (g_c+I1), s				49.8	15.2	17.2
Green Ext Time (p_c), s				2.7	1.7	2.5
<b>Intersection Summary</b>						
HCM 6th Ctrl Delay			22.9			
HCM 6th LOS			C			

Notes

Unsignalized Delay for [WBR, SBR] is excluded from calculations of the approach delay and intersection delay.

Intersection: 8: Calabasas Road & U.S. Highway 101 Ramps

Movement	EB	EB	WB	SB	SB
Directions Served	L	T	T	L	L
Maximum Queue (ft)	167	159	160	115	93
Average Queue (ft)	126	95	154	77	65
95th Queue (ft)	174	180	168	122	101
Link Distance (ft)		2432	1485	104	104
Upstream Blk Time (%)				5	0
Queuing Penalty (veh)				0	0
Storage Bay Dist (ft)	150				
Storage Blk Time (%)	11	3			
Queuing Penalty (veh)	26	4			

Intersection: 8: Calabasas Road & U.S. Highway 101 Ramps

Movement	EB	EB	WB	WB	SB	SB
Directions Served	L	T	T	R	L	L
Maximum Queue (ft)	173	346	208	53	119	119
Average Queue (ft)	112	166	132	11	103	104
95th Queue (ft)	190	326	238	46	148	147
Link Distance (ft)		2432	1485	1485	104	104
Upstream Blk Time (%)					5	11
Queuing Penalty (veh)					0	0
Storage Bay Dist (ft)	150					
Storage Blk Time (%)	3	9				
Queuing Penalty (veh)	11	25				

Intersection: 8: Calabasas Road & U.S. Highway 101 Ramps

Movement	EB	EB	WB	SB	SB
Directions Served	L	T	T	L	L
Maximum Queue (ft)	174	226	278	119	119
Average Queue (ft)	116	126	192	80	83
95th Queue (ft)	177	213	292	118	140
Link Distance (ft)		2432	1485	104	104
Upstream Blk Time (%)				1	4
Queuing Penalty (veh)				0	0
Storage Bay Dist (ft)	150				
Storage Blk Time (%)	7	5			
Queuing Penalty (veh)	18	8			

Intersection: 8: Calabasas Road & U.S. Highway 101 Ramps

Movement	EB	EB	WB	SB	SB
Directions Served	L	T	T	L	L
Maximum Queue (ft)	174	280	180	119	119
Average Queue (ft)	159	184	154	109	88
95th Queue (ft)	194	303	180	126	152
Link Distance (ft)		2432	1485	104	104
Upstream Blk Time (%)				12	9
Queuing Penalty (veh)				0	0
Storage Bay Dist (ft)	150				
Storage Blk Time (%)	15	6			
Queuing Penalty (veh)	59	18			

Intersection: 8: Calabasas Road & U.S. Highway 101 Ramps

Movement	EB	EB	WB	SB	SB
Directions Served	L	T	T	L	L
Maximum Queue (ft)	170	199	223	119	119
Average Queue (ft)	132	141	142	70	96
95th Queue (ft)	196	213	217	121	142
Link Distance (ft)		2412	1485	104	104
Upstream Blk Time (%)				8	7
Queuing Penalty (veh)				0	0
Storage Bay Dist (ft)	150				
Storage Blk Time (%)	4	2			
Queuing Penalty (veh)	9	5			

Intersection: 8: Calabasas Road & U.S. Highway 101 Ramps

Movement	EB	EB	WB	SB	SB
Directions Served	L	T	T	L	L
Maximum Queue (ft)	174	495	136	143	119
Average Queue (ft)	165	310	101	121	105
95th Queue (ft)	191	543	131	139	130
Link Distance (ft)		2412	1485	104	104
Upstream Blk Time (%)				26	12
Queuing Penalty (veh)				0	0
Storage Bay Dist (ft)	150				
Storage Blk Time (%)	27	7			
Queuing Penalty (veh)	107	23			

Queuing and Blocking Report  
Cumulative + Project AM Peak Hour

11/02/2023

Intersection: 8: Calabasas Road & U.S. Highway 101 Ramps

Movement	EB	EB	WB	SB	SB
Directions Served	L	T	T	L	L
Maximum Queue (ft)	174	328	200	119	119
Average Queue (ft)	132	195	167	99	94
95th Queue (ft)	212	327	206	140	132
Link Distance (ft)		2412	1485	104	104
Upstream Blk Time (%)				16	12
Queuing Penalty (veh)				0	0
Storage Bay Dist (ft)	150				
Storage Blk Time (%)	11	9			
Queuing Penalty (veh)	28	20			

Intersection: 8: Calabasas Road & U.S. Highway 101 Ramps

Movement	EB	EB	WB	WB	SB	SB
Directions Served	L	T	T	R	L	L
Maximum Queue (ft)	174	376	171	53	119	119
Average Queue (ft)	139	224	132	11	103	103
95th Queue (ft)	203	401	167	46	136	135
Link Distance (ft)		2412	1485	1485	104	104
Upstream Blk Time (%)					13	9
Queuing Penalty (veh)					0	0
Storage Bay Dist (ft)	150					
Storage Blk Time (%)	14	6				
Queuing Penalty (veh)	63	22				

# HCM Signalized Intersection Capacity Analysis

## 5: Parkway Calabasas /Parkway Calabasas & Calabasas Road

03/13/2024

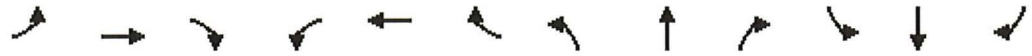

Movement	EBL	EBT	EBR	WBL	WBT	WBR	NBL	NBT	NBR	SBL	SBT	SBR
Lane Configurations	↙	↗	↘	↙	↗	↘	↙	↗	↘	↙	↗	↘
Traffic Volume (vph)	75	313	319	16	101	200	77	690	26	103	471	255
Future Volume (vph)	75	313	319	16	101	200	77	690	26	103	471	255
Ideal Flow (vphpl)	1900	1900	1900	1900	1900	1900	1900	1900	1900	1900	1900	1900
Total Lost time (s)	4.5	4.5	4.5	4.5	4.5	4.5	4.5	4.5	4.5	4.5	4.5	4.5
Lane Util. Factor	1.00	0.95	1.00	1.00	0.95	1.00	1.00	0.91	1.00	0.91	0.91	1.00
Frt	1.00	1.00	0.85	1.00	1.00	0.85	1.00	0.99	1.00	1.00	1.00	0.85
Flt Protected	0.95	1.00	1.00	0.95	1.00	1.00	0.95	1.00	1.00	0.95	1.00	1.00
Satd. Flow (prot)	1770	3539	1583	1770	3539	1583	1770	5058	1610	3387	1583	1583
Flt Permitted	0.95	1.00	1.00	0.95	1.00	1.00	0.95	1.00	1.00	0.95	1.00	1.00
Satd. Flow (perm)	1770	3539	1583	1770	3539	1583	1770	5058	1610	3387	1583	1583
Peak-hour factor, PHF	0.90	0.90	0.90	0.90	0.90	0.90	0.90	0.90	0.90	0.90	0.90	0.90
Adj. Flow (vph)	83	348	354	18	112	222	86	767	29	114	523	283
RTOR Reduction (vph)	0	0	281	0	0	190	0	4	0	0	0	215
Lane Group Flow (vph)	83	348	73	18	112	32	86	792	0	103	534	68
Turn Type	Prot	NA	Perm	Prot	NA	Perm	Split	NA	Split	NA	Perm	Perm
Protected Phases	7	4		3	8		2	2		6	6	
Permitted Phases			4			8						6
Actuated Green, G (s)	7.5	18.6	18.6	2.0	13.1	13.1	29.9	29.9		21.5	21.5	21.5
Effective Green, g (s)	7.5	18.6	18.6	2.0	13.1	13.1	29.9	29.9		21.5	21.5	21.5
Actuated g/C Ratio	0.08	0.21	0.21	0.02	0.15	0.15	0.33	0.33		0.24	0.24	0.24
Clearance Time (s)	4.5	4.5	4.5	4.5	4.5	4.5	4.5	4.5		4.5	4.5	4.5
Vehicle Extension (s)	3.0	3.0	3.0	3.0	3.0	3.0	3.0	3.0		3.0	3.0	3.0
Lane Grp Cap (vph)	147	731	327	39	515	230	588	1680		384	809	378
v/s Ratio Prot	c0.05	c0.10		0.01	0.03		0.05	c0.16		0.06	c0.16	
v/s Ratio Perm			0.05			0.02						0.04
v/c Ratio	0.56	0.48	0.22	0.46	0.22	0.14	0.15	0.47		0.27	0.66	0.18
Uniform Delay, d1	39.7	31.4	29.7	43.5	33.9	33.5	21.1	23.8		27.9	30.9	27.2
Progression Factor	0.96	1.01	2.49	1.00	1.00	1.00	1.00	1.00		1.00	1.00	1.00
Incremental Delay, d2	4.8	0.5	0.3	8.4	0.2	0.3	0.5	1.0		1.7	4.2	1.0
Delay (s)	43.0	32.4	74.2	51.9	34.1	33.8	21.6	24.7		29.6	35.2	28.3
Level of Service	D	C	E	D	C	C	C	C		C	D	C
Approach Delay (s)		52.3			34.8			24.4			32.4	
Approach LOS		D			C			C			C	

### Intersection Summary

HCM 2000 Control Delay	35.6	HCM 2000 Level of Service	D
HCM 2000 Volume to Capacity ratio	0.55		
Actuated Cycle Length (s)	90.0	Sum of lost time (s)	18.0
Intersection Capacity Utilization	51.5%	ICU Level of Service	A
Analysis Period (min)	15		

c Critical Lane Group

# HCM Signalized Intersection Capacity Analysis

## 5: Parkway Calabasas /Parkway Calabasas & Calabasas Road

03/13/2024

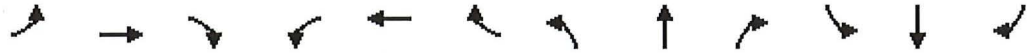

Movement	EBL	EBT	EBR	WBL	WBT	WBR	NBL	NBT	NBR	SBL	SBT	SBR
Lane Configurations												
Traffic Volume (vph)	97	474	270	52	124	339	49	579	33	189	337	282
Future Volume (vph)	97	474	270	52	124	339	49	579	33	189	337	282
Ideal Flow (vphpl)	1900	1900	1900	1900	1900	1900	1900	1900	1900	1900	1900	1900
Total Lost time (s)	4.5	4.5	4.5	4.5	4.5	4.5	4.5	4.5		4.5	4.5	4.5
Lane Util. Factor	1.00	0.95	1.00	1.00	0.95	1.00	1.00	0.91		0.91	0.91	1.00
Fr't	1.00	1.00	0.85	1.00	1.00	0.85	1.00	0.99		1.00	1.00	0.85
Flt Protected	0.95	1.00	1.00	0.95	1.00	1.00	0.95	1.00		0.95	1.00	1.00
Satd. Flow (prot)	1770	3539	1583	1770	3539	1583	1770	5044		1610	3381	1583
Flt Permitted	0.95	1.00	1.00	0.95	1.00	1.00	0.95	1.00		0.95	1.00	1.00
Satd. Flow (perm)	1770	3539	1583	1770	3539	1583	1770	5044		1610	3381	1583
Peak-hour factor, PHF	0.94	0.94	0.94	0.94	0.94	0.94	0.94	0.94	0.94	0.94	0.94	0.94
Adj. Flow (vph)	103	504	287	55	132	361	52	616	35	201	359	300
RTOR Reduction (vph)	0	0	222	0	0	292	0	6	0	0	0	235
Lane Group Flow (vph)	103	504	65	55	132	69	52	645	0	181	379	65
Turn Type	Prot	NA	Perm	Prot	NA	Perm	Split	NA		Split	NA	Perm
Protected Phases	7	4		3	8		2	2		6	6	
Permitted Phases			4			8						6
Actuated Green, G (s)	8.6	20.3	20.3	5.6	17.3	17.3	26.6	26.6		19.5	19.5	19.5
Effective Green, g (s)	8.6	20.3	20.3	5.6	17.3	17.3	26.6	26.6		19.5	19.5	19.5
Actuated g/C Ratio	0.10	0.23	0.23	0.06	0.19	0.19	0.30	0.30		0.22	0.22	0.22
Clearance Time (s)	4.5	4.5	4.5	4.5	4.5	4.5	4.5	4.5		4.5	4.5	4.5
Vehicle Extension (s)	3.0	3.0	3.0	3.0	3.0	3.0	3.0	3.0		3.0	3.0	3.0
Lane Grp Cap (vph)	169	798	357	110	680	304	523	1490		348	732	342
v/s Ratio Prot	c0.06	c0.14		0.03	0.04		0.03	c0.13		c0.11	0.11	
v/s Ratio Perm			0.04			0.04						0.04
v/c Ratio	0.61	0.63	0.18	0.50	0.19	0.23	0.10	0.43		0.52	0.52	0.19
Uniform Delay, d1	39.1	31.5	28.1	40.8	30.5	30.7	23.0	25.6		31.1	31.1	28.8
Progression Factor	0.95	0.96	2.03	1.00	1.00	1.00	1.00	1.00		1.00	1.00	1.00
Incremental Delay, d2	5.9	1.6	0.2	3.5	0.1	0.4	0.4	0.9		5.5	2.6	1.2
Delay (s)	43.0	31.7	57.4	44.4	30.6	31.1	23.4	26.5		36.6	33.7	30.0
Level of Service	D	C	E	D	C	C	C	C		D	C	C
Approach Delay (s)		41.2			32.3			26.3			33.0	
Approach LOS		D			C			C			C	

### Intersection Summary





























HCM 2000 Control Delay	33.8	HCM 2000 Level of Service	C
HCM 2000 Volume to Capacity ratio	0.54		
Actuated Cycle Length (s)	90.0	Sum of lost time (s)	18.0
Intersection Capacity Utilization	54.1%	ICU Level of Service	A
Analysis Period (min)	15		

c Critical Lane Group

# HCM Signalized Intersection Capacity Analysis

## 5: Parkway Calabasas /Parkway Calabasas & Calabasas Road

11/02/2023

												
Movement	EBL	EBT	EBR	WBL	WBT	WBR	NBL	NBT	NBR	SBL	SBT	SBR
Lane Configurations		 			 			  			 	
Traffic Volume (vph)	85	315	321	16	104	200	80	690	26	103	471	281
Future Volume (vph)	85	315	321	16	104	200	80	690	26	103	471	281
Ideal Flow (vphpl)	1900	1900	1900	1900	1900	1900	1900	1900	1900	1900	1900	1900
Total Lost time (s)	4.5	4.5	4.5	4.5	4.5	4.5	4.5	4.5		4.5	4.5	4.5
Lane Util. Factor	1.00	0.95	1.00	1.00	0.95	1.00	1.00	0.91		0.91	0.91	1.00
Frt	1.00	1.00	0.85	1.00	1.00	0.85	1.00	0.99		1.00	1.00	0.85
Flt Protected	0.95	1.00	1.00	0.95	1.00	1.00	0.95	1.00		0.95	1.00	1.00
Satd. Flow (prot)	1770	3539	1583	1770	3539	1583	1770	5058		1610	3387	1583
Flt Permitted	0.95	1.00	1.00	0.95	1.00	1.00	0.95	1.00		0.95	1.00	1.00
Satd. Flow (perm)	1770	3539	1583	1770	3539	1583	1770	5058		1610	3387	1583
Peak-hour factor, PHF	0.90	0.90	0.90	0.90	0.90	0.90	0.90	0.90	0.90	0.90	0.90	0.90
Adj. Flow (vph)	94	350	357	18	116	222	89	767	29	114	523	312
RTOR Reduction (vph)	0	0	282	0	0	190	0	4	0	0	0	244
Lane Group Flow (vph)	94	350	75	18	116	32	89	792	0	103	534	68
Turn Type	Prot	NA	Perm	Prot	NA	Perm	Split	NA		Split	NA	Perm
Protected Phases	7	4		3	8		2	2		6	6	
Permitted Phases			4			8						6
Actuated Green, G (s)	8.6	18.8	18.8	2.8	13.0	13.0	30.9	30.9		19.5	19.5	19.5
Effective Green, g (s)	8.6	18.8	18.8	2.8	13.0	13.0	30.9	30.9		19.5	19.5	19.5
Actuated g/C Ratio	0.10	0.21	0.21	0.03	0.14	0.14	0.34	0.34		0.22	0.22	0.22
Clearance Time (s)	4.5	4.5	4.5	4.5	4.5	4.5	4.5	4.5		4.5	4.5	4.5
Vehicle Extension (s)	3.0	3.0	3.0	3.0	3.0	3.0	3.0	3.0		3.0	3.0	3.0
Lane Grp Cap (vph)	169	739	330	55	511	228	607	1736		348	733	342
v/s Ratio Prot	c0.05	c0.10		0.01	0.03		0.05	c0.16		0.06	c0.16	
v/s Ratio Perm			0.05			0.02						0.04
v/c Ratio	0.56	0.47	0.23	0.33	0.23	0.14	0.15	0.46		0.30	0.73	0.20
Uniform Delay, d1	38.9	31.3	29.6	42.7	34.1	33.6	20.4	23.0		29.5	32.8	28.8
Progression Factor	0.93	1.00	2.43	1.00	1.00	1.00	1.00	1.00		1.00	1.00	1.00
Incremental Delay, d2	3.8	0.5	0.3	3.5	0.2	0.3	0.5	0.9		2.2	6.3	1.3
Delay (s)	39.9	31.7	72.2	46.1	34.3	33.9	20.9	23.9		31.7	39.1	30.1
Level of Service	D	C	E	D	C	C	C	C		C	D	C
Approach Delay (s)		50.7			34.6			23.6			35.3	
Approach LOS		D			C			C			D	
<b>Intersection Summary</b>												
HCM 2000 Control Delay			35.9	HCM 2000 Level of Service				D				
HCM 2000 Volume to Capacity ratio			0.56									
Actuated Cycle Length (s)			90.0	Sum of lost time (s)				18.0				
Intersection Capacity Utilization			51.5%	ICU Level of Service				A				
Analysis Period (min)			15									
c Critical Lane Group												

# HCM Signalized Intersection Capacity Analysis

## 5: Parkway Calabasas /Parkway Calabasas & Calabasas Road

11/02/2023



Movement	EBL	EBT	EBR	WBL	WBT	WBR	NBL	NBT	NBR	SBL	SBT	SBR
Lane Configurations												
Traffic Volume (vph)	129	478	273	52	127	339	51	579	33	189	337	300
Future Volume (vph)	129	478	273	52	127	339	51	579	33	189	337	300
Ideal Flow (vphpl)	1900	1900	1900	1900	1900	1900	1900	1900	1900	1900	1900	1900
Total Lost time (s)	4.5	4.5	4.5	4.5	4.5	4.5	4.5	4.5		4.5	4.5	4.5
Lane Util. Factor	1.00	0.95	1.00	1.00	0.95	1.00	1.00	0.91		0.91	0.91	1.00
Fr't	1.00	1.00	0.85	1.00	1.00	0.85	1.00	0.99		1.00	1.00	0.85
Flt Protected	0.95	1.00	1.00	0.95	1.00	1.00	0.95	1.00		0.95	1.00	1.00
Satd. Flow (prot)	1770	3539	1583	1770	3539	1583	1770	5044		1610	3381	1583
Flt Permitted	0.95	1.00	1.00	0.95	1.00	1.00	0.95	1.00		0.95	1.00	1.00
Satd. Flow (perm)	1770	3539	1583	1770	3539	1583	1770	5044		1610	3381	1583
Peak-hour factor, PHF	0.94	0.94	0.94	0.94	0.94	0.94	0.94	0.94	0.94	0.94	0.94	0.94
Adj. Flow (vph)	137	509	290	55	135	361	54	616	35	201	359	319
RTOR Reduction (vph)	0	0	221	0	0	296	0	6	0	0	0	257
Lane Group Flow (vph)	137	509	69	55	135	65	54	645	0	181	379	62
Turn Type	Prot	NA	Perm	Prot	NA	Perm	Split	NA		Split	NA	Perm
Protected Phases	7	4		3	8		2	2		6	6	
Permitted Phases			4			8						6
Actuated Green, G (s)	11.9	21.3	21.3	6.7	16.1	16.1	26.5	26.5		17.5	17.5	17.5
Effective Green, g (s)	11.9	21.3	21.3	6.7	16.1	16.1	26.5	26.5		17.5	17.5	17.5
Actuated g/C Ratio	0.13	0.24	0.24	0.07	0.18	0.18	0.29	0.29		0.19	0.19	0.19
Clearance Time (s)	4.5	4.5	4.5	4.5	4.5	4.5	4.5	4.5		4.5	4.5	4.5
Vehicle Extension (s)	3.0	3.0	3.0	3.0	3.0	3.0	3.0	3.0		3.0	3.0	3.0
Lane Grp Cap (vph)	234	837	374	131	633	283	521	1485		313	657	307
v/s Ratio Prot	c0.08	c0.14		0.03	0.04		0.03	c0.13		c0.11	0.11	
v/s Ratio Perm			0.04			0.04						0.04
v/c Ratio	0.59	0.61	0.18	0.42	0.21	0.23	0.10	0.43		0.58	0.58	0.20
Uniform Delay, d1	36.7	30.6	27.4	39.8	31.5	31.6	23.1	25.7		32.9	32.9	30.4
Progression Factor	0.93	0.96	1.93	1.00	1.00	1.00	1.00	1.00		1.00	1.00	1.00
Incremental Delay, d2	3.5	1.2	0.2	2.2	0.2	0.4	0.4	0.9		7.6	3.7	1.5
Delay (s)	37.7	30.5	53.0	42.0	31.7	32.0	23.5	26.6		40.5	36.6	31.9
Level of Service	D	C	D	D	C	C	C	C		D	D	C
Approach Delay (s)		38.5			33.0			26.4			35.7	
Approach LOS		D			C			C			D	

### Intersection Summary

HCM 2000 Control Delay	33.9	HCM 2000 Level of Service	C
HCM 2000 Volume to Capacity ratio	0.55		
Actuated Cycle Length (s)	90.0	Sum of lost time (s)	18.0
Intersection Capacity Utilization	54.2%	ICU Level of Service	A
Analysis Period (min)	15		

c Critical Lane Group

# HCM Signalized Intersection Capacity Analysis

## 5: Parkway Calabasas /Parkway Calabasas & Calabasas Road

11/02/2023



Movement	EBL	EBT	EBR	WBL	WBT	WBR	NBL	NBT	NBR	SBL	SBT	SBR
Lane Configurations												
Traffic Volume (vph)	89	331	329	17	130	208	99	718	27	111	485	318
Future Volume (vph)	89	331	329	17	130	208	99	718	27	111	485	318
Ideal Flow (vphpl)	1900	1900	1900	1900	1900	1900	1900	1900	1900	1900	1900	1900
Total Lost time (s)	4.5	4.5	4.5	4.5	4.5	4.5	4.5	4.5		4.5	4.5	4.5
Lane Util. Factor	1.00	0.95	1.00	1.00	0.95	1.00	1.00	0.91		0.91	0.91	1.00
Fr't	1.00	1.00	0.85	1.00	1.00	0.85	1.00	0.99		1.00	1.00	0.85
Flt Protected	0.95	1.00	1.00	0.95	1.00	1.00	0.95	1.00		0.95	1.00	1.00
Satd. Flow (prot)	1770	3539	1583	1770	3539	1583	1770	5058		1610	3387	1583
Flt Permitted	0.95	1.00	1.00	0.95	1.00	1.00	0.95	1.00		0.95	1.00	1.00
Satd. Flow (perm)	1770	3539	1583	1770	3539	1583	1770	5058		1610	3387	1583
Peak-hour factor, PHF	0.90	0.90	0.90	0.90	0.90	0.90	0.90	0.90	0.90	0.90	0.90	0.90
Adj. Flow (vph)	99	368	366	19	144	231	110	798	30	123	539	353
RTOR Reduction (vph)	0	0	287	0	0	197	0	4	0	0	0	284
Lane Group Flow (vph)	99	368	79	19	144	34	110	824	0	111	551	69
Turn Type	Prot	NA	Perm	Prot	NA	Perm	Split	NA		Split	NA	Perm
Protected Phases	7	4		3	8		2	2		6	6	
Permitted Phases			4			8						6
Actuated Green, G (s)	9.1	19.4	19.4	3.0	13.3	13.3	32.1	32.1		17.5	17.5	17.5
Effective Green, g (s)	9.1	19.4	19.4	3.0	13.3	13.3	32.1	32.1		17.5	17.5	17.5
Actuated g/C Ratio	0.10	0.22	0.22	0.03	0.15	0.15	0.36	0.36		0.19	0.19	0.19
Clearance Time (s)	4.5	4.5	4.5	4.5	4.5	4.5	4.5	4.5		4.5	4.5	4.5
Vehicle Extension (s)	3.0	3.0	3.0	3.0	3.0	3.0	3.0	3.0		3.0	3.0	3.0
Lane Grp Cap (vph)	178	762	341	59	522	233	631	1804		313	658	307
v/s Ratio Prot	c0.06	c0.10		0.01	0.04		0.06	c0.16		0.07	c0.16	
v/s Ratio Perm			0.05			0.02						0.04
v/c Ratio	0.56	0.48	0.23	0.32	0.28	0.15	0.17	0.46		0.35	0.84	0.22
Uniform Delay, d1	38.5	30.9	29.1	42.5	34.1	33.4	19.9	22.2		31.4	34.9	30.5
Progression Factor	0.83	0.91	2.41	1.00	1.00	1.00	1.00	1.00		1.00	1.00	1.00
Incremental Delay, d2	3.6	0.5	0.3	3.2	0.3	0.3	0.6	0.8		3.1	12.1	1.7
Delay (s)	35.6	28.5	70.7	45.7	34.4	33.7	20.5	23.1		34.5	47.0	32.2
Level of Service	D	C	E	D	C	C	C	C		C	D	C
Approach Delay (s)		47.9			34.5			22.8			40.5	
Approach LOS		D			C			C			D	

### Intersection Summary

HCM 2000 Control Delay	36.5	HCM 2000 Level of Service	D
HCM 2000 Volume to Capacity ratio	0.58		
Actuated Cycle Length (s)	90.0	Sum of lost time (s)	18.0
Intersection Capacity Utilization	56.2%	ICU Level of Service	B
Analysis Period (min)	15		

c Critical Lane Group

# HCM Signalized Intersection Capacity Analysis

## 5: Parkway Calabasas /Parkway Calabasas & Calabasas Road

11/02/2023



Movement	EBL	EBT	EBR	WBL	WBT	WBR	NBL	NBT	NBR	SBL	SBT	SBR
Lane Configurations												
Traffic Volume (vph)	125	505	282	54	160	357	61	597	27	206	355	337
Future Volume (vph)	125	505	282	54	160	357	61	597	27	206	355	337
Ideal Flow (vphpl)	1900	1900	1900	1900	1900	1900	1900	1900	1900	1900	1900	1900
Total Lost time (s)	4.5	4.5	4.5	4.5	4.5	4.5	4.5	4.5		4.5	4.5	4.5
Lane Util. Factor	1.00	0.95	1.00	1.00	0.95	1.00	1.00	0.91		0.91	0.91	1.00
Fr't	1.00	1.00	0.85	1.00	1.00	0.85	1.00	0.99		1.00	1.00	0.85
Flt Protected	0.95	1.00	1.00	0.95	1.00	1.00	0.95	1.00		0.95	1.00	1.00
Sat'd. Flow (prot)	1770	3539	1583	1770	3539	1583	1770	5052		1610	3379	1583
Flt Permitted	0.95	1.00	1.00	0.95	1.00	1.00	0.95	1.00		0.95	1.00	1.00
Sat'd. Flow (perm)	1770	3539	1583	1770	3539	1583	1770	5052		1610	3379	1583
Peak-hour factor, PHF	0.94	0.94	0.94	0.94	0.94	0.94	0.94	0.94	0.94	0.94	0.94	0.94
Adj. Flow (vph)	133	537	300	57	170	380	65	635	29	219	378	359
RTOR Reduction (vph)	0	0	228	0	0	310	0	5	0	0	0	289
Lane Group Flow (vph)	133	537	72	57	170	70	65	659	0	193	404	70
Turn Type	Prot	NA	Perm	Prot	NA	Perm	Split	NA		Split	NA	Perm
Protected Phases	7	4		3	8		2	2		6	6	
Permitted Phases			4			8						6
Actuated Green, G (s)	11.6	21.5	21.5	6.7	16.6	16.6	26.3	26.3		17.5	17.5	17.5
Effective Green, g (s)	11.6	21.5	21.5	6.7	16.6	16.6	26.3	26.3		17.5	17.5	17.5
Actuated g/C Ratio	0.13	0.24	0.24	0.07	0.18	0.18	0.29	0.29		0.19	0.19	0.19
Clearance Time (s)	4.5	4.5	4.5	4.5	4.5	4.5	4.5	4.5		4.5	4.5	4.5
Vehicle Extension (s)	3.0	3.0	3.0	3.0	3.0	3.0	3.0	3.0		3.0	3.0	3.0
Lane Grp Cap (vph)	228	845	378	131	652	291	517	1476		313	657	307
v/s Ratio Prot	c0.08	c0.15		0.03	0.05		0.04	c0.13		c0.12	0.12	
v/s Ratio Perm			0.05			0.04						0.04
v/c Ratio	0.58	0.64	0.19	0.44	0.26	0.24	0.13	0.45		0.62	0.61	0.23
Uniform Delay, d1	36.9	30.7	27.3	39.8	31.4	31.3	23.4	25.9		33.2	33.2	30.6
Progression Factor	0.86	0.87	2.05	1.00	1.00	1.00	1.00	1.00		1.00	1.00	1.00
Incremental Delay, d2	3.5	1.5	0.2	2.3	0.2	0.4	0.5	1.0		8.8	4.3	1.7
Delay (s)	35.2	28.1	56.2	42.1	31.7	31.8	23.9	26.9		42.0	37.4	32.3
Level of Service	D	C	E	D	C	C	C	C		D	D	C
Approach Delay (s)		37.8			32.7			26.6			36.4	
Approach LOS		D			C			C			D	

Intersection Summary			
HCM 2000 Control Delay	33.9	HCM 2000 Level of Service	C
HCM 2000 Volume to Capacity ratio	0.58		
Actuated Cycle Length (s)	90.0	Sum of lost time (s)	18.0
Intersection Capacity Utilization	55.8%	ICU Level of Service	B
Analysis Period (min)	15		

c Critical Lane Group

HCM Signalized Intersection Capacity Analysis  
 5: Parkway Calabasas /Parkway Calabasas & Calabasas Road

11/02/2023



Movement	EBL	EBT	EBR	WBL	WBT	WBR	NBL	NBT	NBR	SBL	SBT	SBR
Lane Configurations												
Traffic Volume (vph)	99	333	331	17	133	208	102	718	27	111	485	344
Future Volume (vph)	99	333	331	17	133	208	102	718	27	111	485	344
Ideal Flow (vphpl)	1900	1900	1900	1900	1900	1900	1900	1900	1900	1900	1900	1900
Total Lost time (s)	4.5	4.5	4.5	4.5	4.5	4.5	4.5	4.5		4.5	4.5	4.5
Lane Util. Factor	1.00	0.95	1.00	1.00	0.95	1.00	1.00	0.91		0.91	0.91	1.00
Flt	1.00	1.00	0.85	1.00	1.00	0.85	1.00	0.99		1.00	1.00	0.85
Flt Protected	0.95	1.00	1.00	0.95	1.00	1.00	0.95	1.00		0.95	1.00	1.00
Satd. Flow (prot)	1770	3539	1583	1770	3539	1583	1770	5058		1610	3387	1583
Flt Permitted	0.95	1.00	1.00	0.95	1.00	1.00	0.95	1.00		0.95	1.00	1.00
Satd. Flow (perm)	1770	3539	1583	1770	3539	1583	1770	5058		1610	3387	1583
Peak-hour factor, PHF	0.90	0.90	0.90	0.90	0.90	0.90	0.90	0.90	0.90	0.90	0.90	0.90
Adj. Flow (vph)	110	370	368	19	148	231	113	798	30	123	539	382
RTOR Reduction (vph)	0	0	287	0	0	197	0	4	0	0	0	312
Lane Group Flow (vph)	110	370	81	19	148	34	113	824	0	111	551	70
Turn Type	Prot	NA	Perm	Prot	NA	Perm	Split	NA		Split	NA	Perm
Protected Phases	7	4		3	8		2	2		6	6	
Permitted Phases			4			8						6
Actuated Green, G (s)	9.6	19.7	19.7	3.0	13.1	13.1	32.8	32.8		16.5	16.5	16.5
Effective Green, g (s)	9.6	19.7	19.7	3.0	13.1	13.1	32.8	32.8		16.5	16.5	16.5
Actuated g/C Ratio	0.11	0.22	0.22	0.03	0.15	0.15	0.36	0.36		0.18	0.18	0.18
Clearance Time (s)	4.5	4.5	4.5	4.5	4.5	4.5	4.5	4.5		4.5	4.5	4.5
Vehicle Extension (s)	3.0	3.0	3.0	3.0	3.0	3.0	3.0	3.0		3.0	3.0	3.0
Lane Grp Cap (vph)	188	774	346	59	515	230	645	1843		295	620	290
v/s Ratio Prot	c0.06	c0.10		0.01	0.04		0.06	c0.16		0.07	c0.16	
v/s Ratio Perm			0.05			0.02						0.04
v/c Ratio	0.59	0.48	0.23	0.32	0.29	0.15	0.18	0.45		0.38	0.89	0.24
Uniform Delay, d1	38.3	30.7	28.9	42.5	34.3	33.6	19.4	21.7		32.2	35.9	31.4
Progression Factor	0.82	0.86	2.32	1.00	1.00	1.00	1.00	1.00		1.00	1.00	1.00
Incremental Delay, d2	4.4	0.4	0.3	3.2	0.3	0.3	0.6	0.8		3.6	17.2	2.0
Delay (s)	35.8	26.8	67.3	45.7	34.6	33.9	20.0	22.5		35.9	53.1	33.4
Level of Service	D	C	E	D	C	C	C	C		D	D	C
Approach Delay (s)		45.5			34.7			22.2			44.0	
Approach LOS		D			C			C			D	

Intersection Summary		
HCM 2000 Control Delay	36.9	HCM 2000 Level of Service
HCM 2000 Volume to Capacity ratio	0.59	D
Actuated Cycle Length (s)	90.0	Sum of lost time (s)
Intersection Capacity Utilization	56.3%	18.0
Analysis Period (min)	15	ICU Level of Service
		B

c Critical Lane Group

HCM Signalized Intersection Capacity Analysis  
 5: Parkway Calabasas /Parkway Calabasas & Calabasas Road

11/02/2023



Movement	EBL	EBT	EBR	WBL	WBT	WBR	NBL	NBT	NBR	SBL	SBT	SBR
Lane Configurations												
Traffic Volume (vph)	157	509	285	54	163	357	63	597	27	206	355	355
Future Volume (vph)	157	509	285	54	163	357	63	597	27	206	355	355
Ideal Flow (vphpl)	1900	1900	1900	1900	1900	1900	1900	1900	1900	1900	1900	1900
Total Lost time (s)	4.5	4.5	4.5	4.5	4.5	4.5	4.5	4.5		4.5	4.5	4.5
Lane Util. Factor	1.00	0.95	1.00	1.00	0.95	1.00	1.00	0.91		0.91	0.91	1.00
Frst	1.00	1.00	0.85	1.00	1.00	0.85	1.00	0.99		1.00	1.00	0.85
Flt Protected	0.95	1.00	1.00	0.95	1.00	1.00	0.95	1.00		0.95	1.00	1.00
Satd. Flow (prot)	1770	3539	1583	1770	3539	1583	1770	5052		1610	3379	1583
Flt Permitted	0.95	1.00	1.00	0.95	1.00	1.00	0.95	1.00		0.95	1.00	1.00
Satd. Flow (perm)	1770	3539	1583	1770	3539	1583	1770	5052		1610	3379	1583
Peak-hour factor, PHF	0.94	0.94	0.94	0.94	0.94	0.94	0.94	0.94	0.94	0.94	0.94	0.94
Adj. Flow (vph)	167	541	303	57	173	380	67	635	29	219	378	378
RTOR Reduction (vph)	0	0	229	0	0	315	0	5	0	0	0	309
Lane Group Flow (vph)	167	541	74	57	173	65	67	659	0	193	404	69
Turn Type	Prot	NA	Perm	Prot	NA	Perm	Split	NA		Split	NA	Perm
Protected Phases	7	4		3	8		2	2		6	6	
Permitted Phases			4			8						6
Actuated Green, G (s)	13.2	22.0	22.0	6.7	15.5	15.5	26.8	26.8		16.5	16.5	16.5
Effective Green, g (s)	13.2	22.0	22.0	6.7	15.5	15.5	26.8	26.8		16.5	16.5	16.5
Actuated g/C Ratio	0.15	0.24	0.24	0.07	0.17	0.17	0.30	0.30		0.18	0.18	0.18
Clearance Time (s)	4.5	4.5	4.5	4.5	4.5	4.5	4.5	4.5		4.5	4.5	4.5
Vehicle Extension (s)	3.0	3.0	3.0	3.0	3.0	3.0	3.0	3.0		3.0	3.0	3.0
Lane Grp Cap (vph)	259	865	386	131	609	272	527	1504		295	619	290
v/s Ratio Prot	c0.09	c0.15		0.03	0.05		0.04	c0.13		c0.12	0.12	
v/s Ratio Perm			0.05			0.04						0.04
v/c Ratio	0.64	0.63	0.19	0.44	0.28	0.24	0.13	0.44		0.65	0.65	0.24
Uniform Delay, d1	36.2	30.3	27.0	39.8	32.4	32.2	23.1	25.5		34.1	34.1	31.4
Progression Factor	0.88	0.84	1.93	1.00	1.00	1.00	1.00	1.00		1.00	1.00	1.00
Incremental Delay, d2	5.0	1.3	0.2	2.3	0.3	0.5	0.5	0.9		10.8	5.3	1.9
Delay (s)	36.7	26.8	52.1	42.1	32.7	32.6	23.6	26.5		44.9	39.4	33.3
Level of Service	D	C	D	D	C	C	C	C		D	D	C
Approach Delay (s)		36.1			33.5			26.2			38.1	
Approach LOS		D			C			C			D	

Intersection Summary		
HCM 2000 Control Delay	34.0	HCM 2000 Level of Service C
HCM 2000 Volume to Capacity ratio	0.59	
Actuated Cycle Length (s)	90.0	Sum of lost time (s) 18.0
Intersection Capacity Utilization	55.9%	ICU Level of Service B
Analysis Period (min)	15	

c Critical Lane Group

**CITY OF CALABASAS APPROVED DEVELOPMENT PROJECTS**

Figure 8 – Related Projects Map



Table 4 provides information related to related project with the corresponding traffic volumes at the study intersections:

Table 4 -Related Projects List & Trip Generation

#	Project Name	Location	Land Use	Size	Unit	Daily Trips	Weekday Peak Hour					
							AM			PM		
							In	Out	Total	In	Out	Total
1	The Park Apartments	24100 Park Sorrento	Residential/Commercial	107	DU	368	11	36	47	27	15	42
2	Calabasas Commons	4799 Commons Way	Residential/Commercial	202	DU	695	20	68	89	51	28	79
3	Kia Car Dealership	24460 Calabasas Rd	Commercial	47,944	Sq Ft	1335	56	47	103	58	69	127
4	Calabasas Auto Park	23823 Ventura Blvd	Commercial	31,683	Sq Ft	46	3	3	6	3	3	6
5	Hidden Terraces Specific Plan	Mureau Rd near Crummer Canyon Rd	Residential	180	DU	583	23	29	52	29	25	54
5	Hidden Terraces Specific Plan	Mureau Rd near Crummer Canyon Rd	Residential	83	Beds	216	12	6	18	12	15	27

Refer to Figure 9 below for illustration showing the Related Projects’ Trip Assignments at the study intersections.