

City of Calabasas

Rondell Oasis Hotel Project

Draft
**Initial Study -
Mitigated
Negative
Declaration**



November 2015

Rondell Oasis Hotel Project

Draft

Initial Study – Mitigated Negative Declaration

Prepared by:

City of Calabasas
100 Civic Center Way
Calabasas, California 91302
Michael Klein, Planner
(818) 224-1710

Prepared with the assistance of:

Rincon Consultants, Inc.
180 North Ashwood Avenue
Ventura, California 93003

November 2015

This report is printed on 50% recycled paper.

Table of Contents

	Page
Initial Study	1
1. Project Title:.....	1
2. Lead Agency Name and Address:	1
3. Contact Person and Phone Number:	1
4. Project Location:	1
5. Project Sponsor’s Name and Address	1
6. General Plan Designation:.....	1
7. Zoning:.....	1
8. Description of Project:.....	1
10. Surrounding Land Uses and Setting:.....	3
11. Other Public Agencies Whose Approval is Required:	3
Environmental Factors Potentially Affected.....	21
Determination	22
Environmental Checklist	23
I. Aesthetics.....	23
II. Agriculture and Forest Resources	41
III. Air Quality.....	42
IV. Biological Resources.....	49
V. Cultural Resources	56
VI. Geology and Soils	58
VII. Greenhouse Gas Emissions	62
VIII. Hazards and Hazardous Materials	66
IX. Hydrology and Water Quality.....	69
X. Land Use and Planning	72
XI. Mineral Resources	73
XII. Noise.....	74
XIII. Population and Housing	83
XIV. Public Services	85
XV. Recreation	88
XVI. Transportation/Traffic.....	88
XVII. Utilities and Service Systems	97
XVIII. Mandatory Findings of Significance	103
References	105
Bibliography.....	105
Persons Contacted	108

List of Figures

Figure 1 Regional Location.....	4
Figure 2 Project Location.....	5
Figure 3 Site Plan.....	6
Figure 4 Grading and Drainage Plan	9
Figure 5a Site Photos	11



Figure 5b Site Photos	12
Figure 5c Site Photos.....	13
Figure 5d Site Photos.....	14
Figure 5e Site Photos.....	15
Figure 6 Site Planting Plan.....	16
Figure 7 Drainage Details	19
Figure 8a Project Photosimulations	26
Figure 8b Project Photosimulations.....	27
Figure 9a Sight Line Plan For Section A-A.....	28
Figure 9b Sight Line Plan for Section B-B.....	29
Figure 9c Sight Line Plan for Section C-C.....	30
Figure 9d Sight Line Plan for Section F-F	31
Figure 9e Sight Line Plan for Section F-F.....	32
Figure 10a Project Elevations.....	33
Figure 10b Project Elevations	35
Figure 11 Site Photometrics	39
Figure 12 Land Use Compatibility for Community Noise Environments.....	78

List of Tables

Table 1 Proposed Project Characteristics	3
Table 2 Health Effects Associated with Criteria Pollutants.....	43
Table 3 SCAQMD Air Quality Significance Thresholds	44
Table 4 SCAQMD LSTs for Construction	45
Table 5 Estimated Construction Maximum Daily Air Pollutant Emissions	48
Table 6 Estimated Project Operational Emissions	49
Table 7 Plant and Wildlife Species Observed.....	51
Table 8 Estimated Construction Emissions of Greenhouse Gases	64
Table 9 Combined Annual Emissions of Greenhouse Gases	65
Table 10 Measured Noise Levels.....	76
Table 11 Typical Noise Levels at Construction Sites.....	80
Table 12 Comparison of Pre-Project and Post-Project Traffic Noise On Project Area Roadways.....	82
Table 13 Vibration Source Levels for Construction Equipment	82
Table 14 Estimated Project Traffic Trip Generation	90
Table 15 Criteria for Significant Traffic Impact.....	91
Table 16 Level of Service for Existing (2014) Conditions.....	91
Table 17 Traffic Conditions for Existing + Project	92
Table 18 Future Cumulative Traffic Conditions without Project	93
Table 19 Future Cumulative Traffic Conditions with Project	93
Table 20 Freeway CMP Analysis.....	96
Table 21 Projected Wastewater Generation	99
Table 22 Project Water Demand.....	100
Table 23 LVMWD Water Supply and Demand in Normal Year and Single and Multiple Dry Years (Acre Feet)	100
Table 24 Project Solid Waste Generation	102



Appendices

Appendix A	Oak Tree Report
Appendix B	Sight Line Study
Appendix C	Air Quality Model Results
Appendix D	Hydrology Study
Appendix E	Noise Measurements and Modeling Results
Appendix F	Traffic Analysis



This page intentionally left blank.



INITIAL STUDY

1. Project Title:

Rondell Oasis Hotel Project

2. Lead Agency Name and Address:

City of Calabasas
100 Civic Center Way
Calabasas, CA 91302

3. Contact Person and Phone Number:

Michael Klein, Planner
(818) 224-1710

4. Project Location:

The project site is located at 26300 Rondell Street in the City of Calabasas along the Ventura Freeway (101 Freeway) corridor. The project site is on the east side of Rondell Street, east of Las Virgenes Road and adjacent to the Ventura Freeway southbound on-ramp. Figure 1 shows the regional location and Figure 2 shows the project site location. The project site is located within the Ventura Freeway and Las Virgenes Scenic Corridor and within the boundaries of the Las Virgenes Gateway Master Plan.

5. Project Sponsor's Name and Address

Rondell Oasis, LLC
P.O. Box 6528
Malibu, CA 90264

6. General Plan Designation:

Business - Retail (B-R)

7. Zoning:

Commercial Retail (CR)

8. Description of Project:

The project site is currently vacant, but was previously graded. The proposed project involves a 4-story hotel with up to 127-rooms, a pool and surface parking on an approximately 4.13-acre property (APN 2069-031-014 and 2069-031-015; see Figure 3 for Site Plan). The hotel would include a lounge area, exercise room, food service, and outdoor pool on the first floor for use by guests of the hotel. The hotel would have a building footprint, including the designated trash area, of approximately 20,410 square feet (sf) and a gross floor area of 72,954 square feet. A porte cochere would be provided at the main entry to the hotel for guests. Additionally, a fire access road would be provided on the south side of the hotel. The proposed hotel would be designed to achieve a LEED silver rating through use of water and energy efficient appliances, landscaping with native and drought-tolerant plants, construction waste management, building life-cycle impact reduction, and a pedestrian- and bicycle-friendly environment.



As part of the development of the site, Rondell Street would be vacated by the City, adding an area of approximately 0.87 acres to the project site. As shown on Figure 3 (Site Plan), Rondell Street would be paved beyond the current terminus along the project frontage and terminate at the north end of the project site. Vehicular access to the new hotel would be from Rondell Street off of Las Virgenes Road. A portion of the project parking would be provided by new perpendicular parking along the vacated portion of Rondell Street. Additional parking would be provided by a surface lot with two access ways off of Rondell Street up a hill to grade level with the hotel. A total of 151 parking spaces are proposed with seven spaces for bicycle parking.

The proposed project would provide access through the project site to the existing trailhead of the Calabasas Historic Trail, also known as the Juan Bautista de Anza Historic Trail, which is located approximately 160 feet east of the project site. The proposed project would also dedicate five parking spaces to trailhead parking and include improvements to the trailhead access, such as trash and recycle receptacles and dog waste pick-up sign, bags, and container.

As shown in Figure 3, a debris impact/deflection wall would replace the existing wall, and would be located behind the proposed hotel. The purpose of the debris wall is to deflect debris away from the hotel and toward an underground debris basin. An Oak Tree Permit is required for the construction of the deflection walls within the protected zone of three oak trees (see Appendix A). Site grading would involve 19,680 cubic yards (CY) of cut and 5,860 CY of fill, with a net export of 13,820 CY (see Figure 4, Grading and Drainage Plan). Photos of the project site are shown in Figures 5a through 5e. Existing oaks and other trees to remain are shown in Figure 6, Site Planting Plan. The proposed project would include a covered debris detention basin designed to detain 7 cubic feet per second (cfs) for a 50-year storm event, which would be the difference between pre- and post-project flows (see Figure 4, Grading and Drainage Plan, and Figure 7, Drainage Details).

Table 1 on the following page summarizes the characteristics of the proposed project.

The project requires a Conditional Use Permit (CUP) to allow for the hotel use in the Commercial-Retail zone and a Development Plan Permit (Calabasas Municipal Code Section 17.62.070) to allow a 50-foot tall structure in the Commercial Retail zone. In addition, the applicant is requesting that the City vacate the portion of Rondell Street that abuts the western property line, an approximately 0.87 acre area.

9. Required Permits:

The following permits are required for the proposed development:

- Conditional Use Permit
- Site Plan Review
- Development Plan Permit
- Scenic Corridor Permit
- Street Vacation
- Lot Line Adjustment
- Oak Tree Permit



10. Surrounding Land Uses and Setting:

The project site is located on the east side of Rondell Street east of Las Virgenes Road. The site is bordered by open space to the east, vacant land to the North, Rondell Street to the west, vacant land to the southeast, and a gas station to the south. Commercial development is located west of the project site across Las Virgenes Road and includes gas stations, a post office, fast food restaurants, and a grocery store. Photos of the project site are shown in Figures 5a through 5e.

11. Other Public Agencies Whose Approval is Required:

The City of Calabasas is the lead agency with responsibility for approving the proposed project.

**Table 1
Proposed Project Characteristics**

Parcels	2069-031-014 and 2069-031-015
Project Site Size <i>Existing lot area</i> <i>Rondell Street addition</i> <i>Gross lot size</i> <i>Utility Easement Area</i> <i>Net lot size</i>	~ 180,146 sf (4.13 acres) ~ 38,053 sf (0.87 acres) ~ 218,199 sf (5 acres) ~ 14,152 sf (0.32 acres) ~ 204,047 sf (4.68 acres)
Hotel Area <i>Total Rooms</i> <i>Total Building Area</i> <i>Floor Area Ratio (FAR)</i>	127 (9 ADA Accessible) 72,954 sf 0.3575 (72,954 sf/204,047 sf)
Parking <i>Regular</i> <i>Handicap</i> <i>Dedicated Trailhead</i> <i>Dedicated Transit</i> <i>Total Parking</i> <i>Bicycle Parking</i>	135 stalls 5 stalls 5 stalls 6 stalls 151 stalls 7 spaces
Building Height	4 stories above grade 50 feet above grade to top of parapet plus 10 feet to top of stairs
Pervious Surface Calculation <i>Building Footprint & Trash Area</i> <i>Landscape Area</i> <i>Pervious Paving</i> <i>Impervious Paving</i> <i>Undeveloped Area</i>	20,410 sf (9% of gross lot size) 26,771 sf (12%) 19,161 sf (9%) 73,592 sf (34%) 78,265 sf (36%)

Notes: sf = square feet





Imagery provided by National Geographic Society, ESRI and its licensors © 2015.

★ Project Location



Regional Location

Figure 1



Imagery provided by Google and its licensors © 2015.

Project Location

Figure 2
City of Calabasas

This page intentionally left blank.



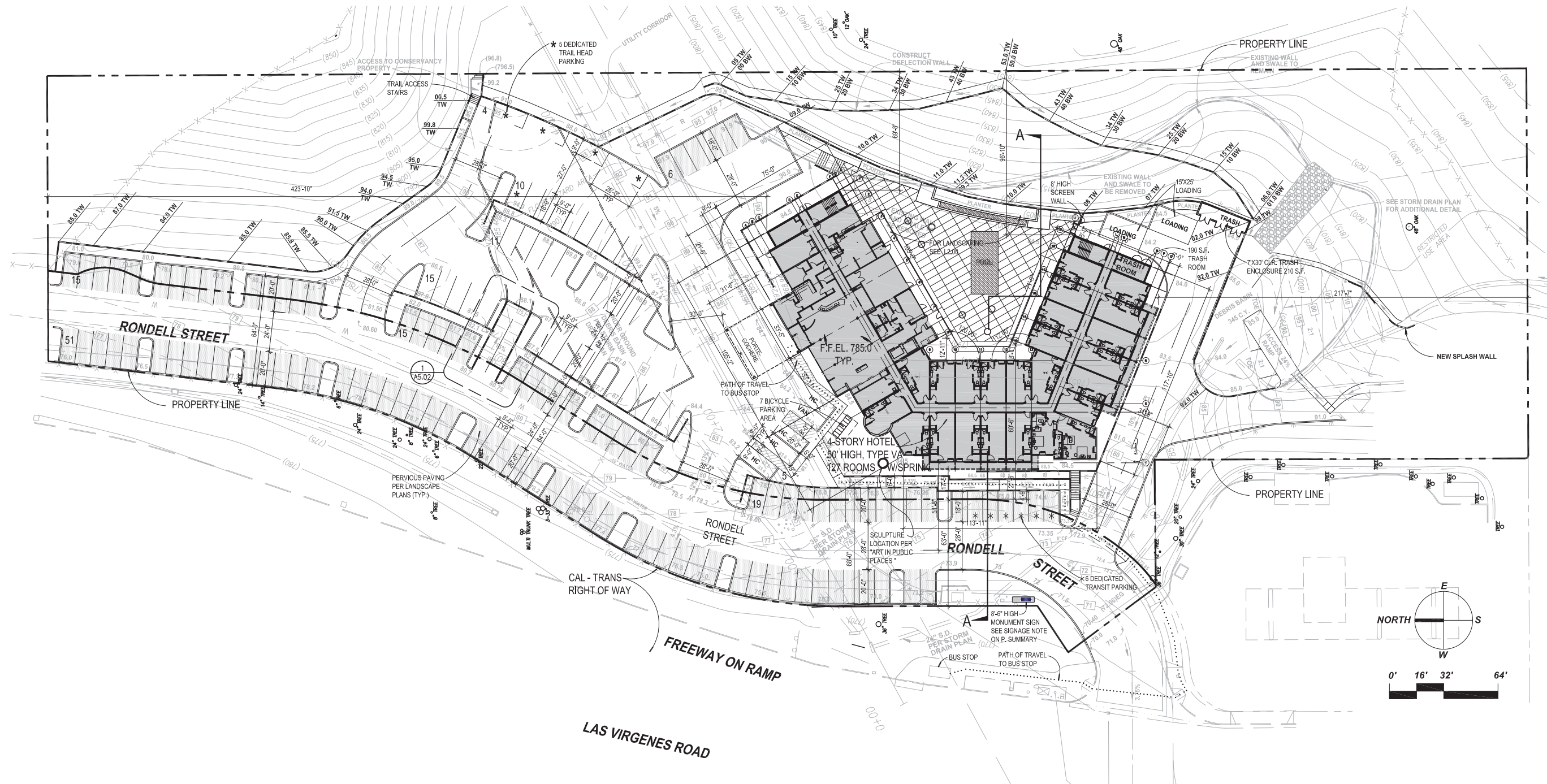

Site Plan

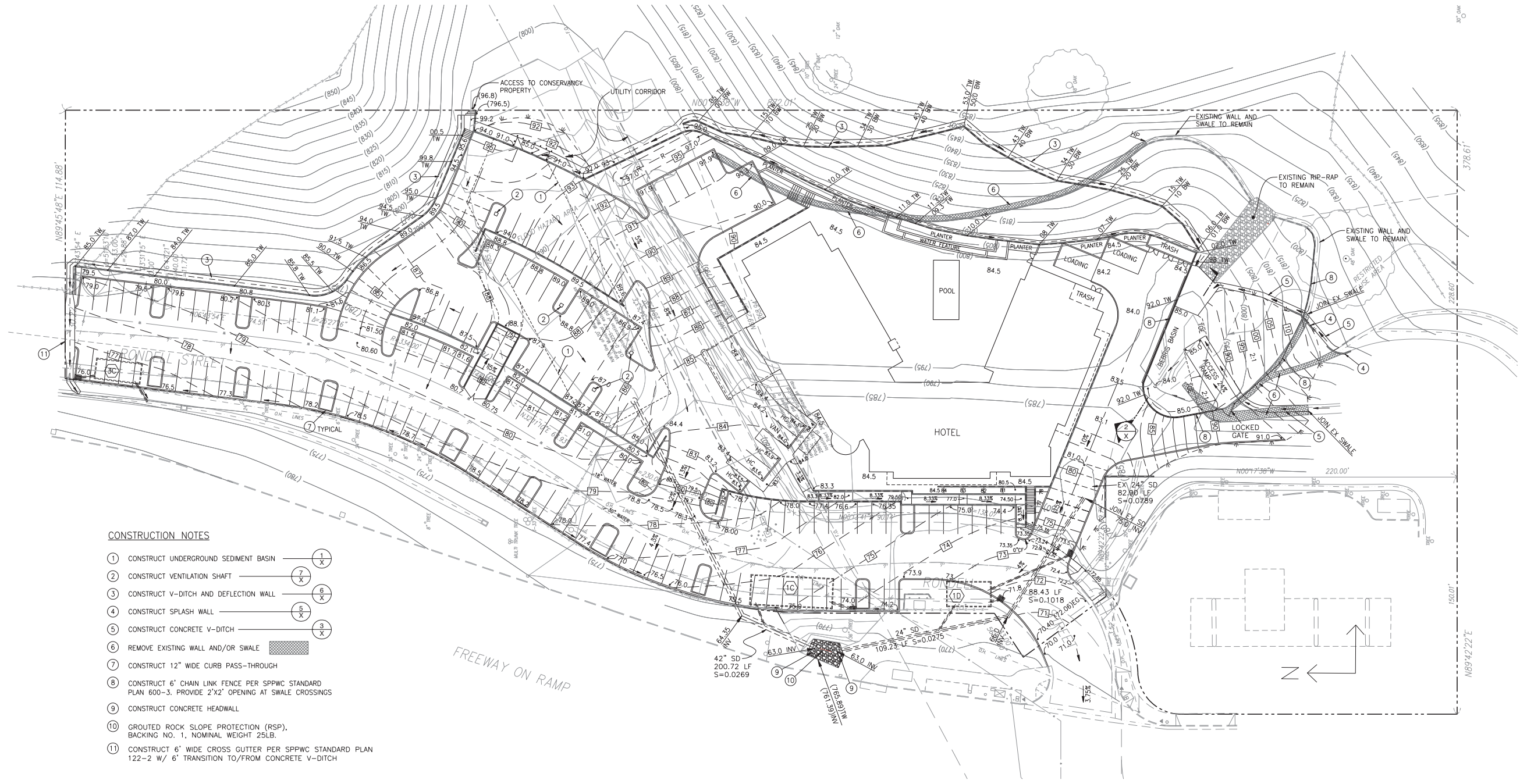

- CONSTRUCTION NOTES**
- 1 CONSTRUCT UNDERGROUND SEDIMENT BASIN
 - 2 CONSTRUCT VENTILATION SHAFT
 - 3 CONSTRUCT V-DITCH AND DEFLECTION WALL
 - 4 CONSTRUCT SPLASH WALL
 - 5 CONSTRUCT CONCRETE V-DITCH
 - 6 REMOVE EXISTING WALL AND/OR SWALE
 - 7 CONSTRUCT 12" WIDE CURB PASS-THROUGH
 - 8 CONSTRUCT 6' CHAIN LINK FENCE PER SPPWC STANDARD PLAN 600-3. PROVIDE 2'X2' OPENING AT SWALE CROSSINGS
 - 9 CONSTRUCT CONCRETE HEADWALL
 - 10 GROUTED ROCK SLOPE PROTECTION (RSP), BACKING NO. 1, NOMINAL WEIGHT 25LB.
 - 11 CONSTRUCT 6' WIDE CROSS GUTTER PER SPPWC STANDARD PLAN 122-2 W/ 6' TRANSITION TO/FROM CONCRETE V-DITCH

LOW IMPACT DESIGN VAULTS					
VAULT ID	DIMENSIONS (FT)	ELEV VAULT FLOOR	ELEV INLET INV	ELEV OUTLET INV	OUTLET PIPE SIZE
1C	51.0L X 18.0W X 8.0H	62.0	67.0	67.5	18"
1D	27.0L X 15.0W X 8.0H	62.0	66.5	67.0	12"
3C	28.0L X 12.0W X 7.0H	68.0	72.5	73.0	12"

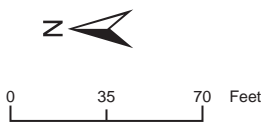

Grading and Drainage Plan

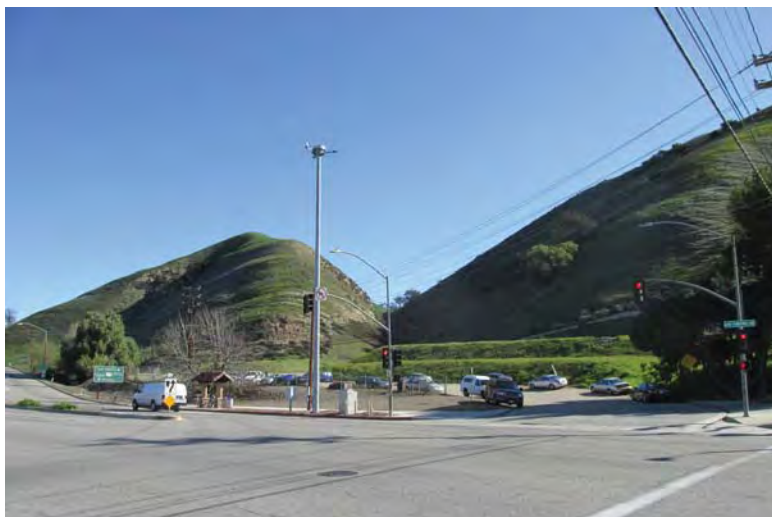

Photo 1: Looking northeast at the project site from across Las Virgenes Road. Vehicles are parked on Rondell Street (dirt lot).



Photo 2: Looking east at the project site and adjacent gas station from across Las Virgenes Road.



Photo 3: Looking southeast at gas station adjacent to the project site from across Las Virgenes Road.



Photo 4: Looking south on Las Virgenes Road at surrounding commercial uses. Shea Colony residences visible in distance.

Site Photos





Photo 5: Looking north on Las Virgenes Road at surrounding commercial uses and 101 Freeway on-ramps.



Photo 6: From approximate location of proposed hotel, looking southwest across Rondell Street (dirt lot) at intersection of Las Virgenes Road and 101 Freeway ramps.



Photo 7: From approximate location of proposed hotel, looking west across Rondell Street (dirt lot) at surrounding commercial uses on Las Virgenes Road.



Photo 8: From approximate location of proposed hotel, looking northwest across Rondell Street (dirt lot) at surrounding commercial uses on Las Virgenes Road.



Photo 9: From approximate location of proposed hotel, looking north along Rondell Street (dirt lot) and at southbound on-ramp to 101 Freeway.



Photo 10: From approximate location of proposed hotel, looking north northeast within project site.



Photo 11: From approximate location of proposed hotel, looking northeast within project site. Proposed building footprints would be located on existing graded pads, shown in photo.



Photo 12: From approximate location of proposed hotel, looking east within project site. Proposed project would replace existing retention wall shown with a wall located uphill. Existing oak trees shown would remain.





Photo 13: From approximate location of proposed hotel, looking southeast within project site. Swale shown on right to remain.



Photo 14: From approximate location of proposed hotel, looking south within project site.



Photo 15: From approximate location of proposed hotel, looking southwest within project site. Rondell Street (dirt lot) and Las Virgenes Road intersection on right.



Photo 16: Trailhead access to the Juan Bautista de Anza Historic Trail, also known as the Calabasas Historic Trail, located 140 feet east of the project site.



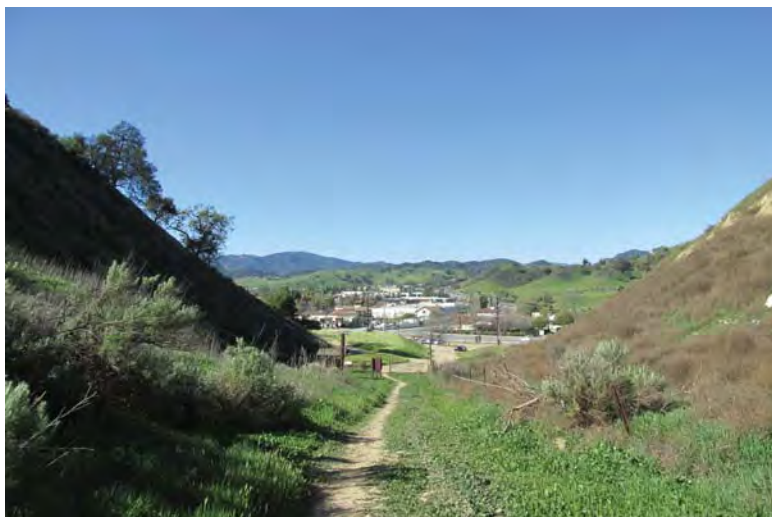

Photo 17: Looking southwest from approximately 180 feet into Juan Bautista de Anza Historic Trail at project site. Proposed hotel and parking would be in view.

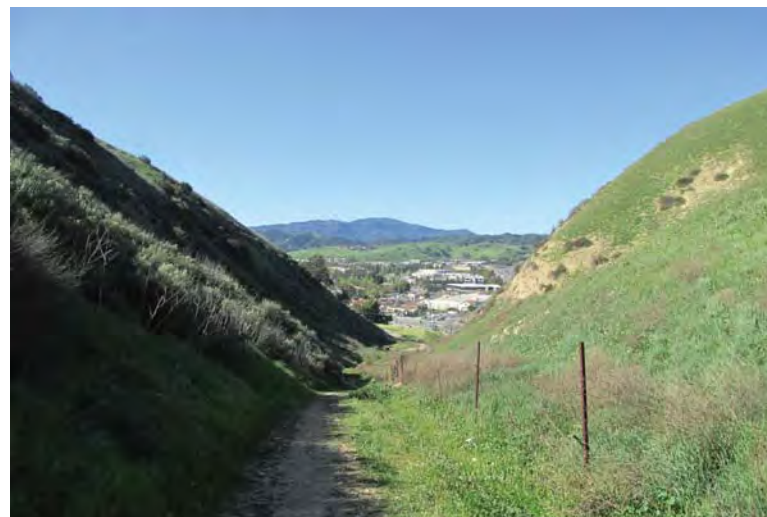

Photo 18: Looking southwest from approximately 550 feet into Juan Bautista de Anza Historic Trail at project site. Proposed hotel and parking would be in view.



Photo 19: Looking southwest from approximately 900 feet into Juan Bautista de Anza Historic Trail at project site. Top of proposed hotel would begin to be visible.



Photo 20: Looking east from entrance to project site at intersection of Rondell Street (dirt lot) and Las Virgenes Road.



This page intentionally left blank.



PARKING LOT SHADE CALCULATION

SYMBOL	BOTANICAL NAME/COMMON NAME	QUANTITY @ FULL SHADE/SQ. FT.	QUANTITY @ 1/2 SHADE/SQ. FT.	TOTAL (SQ. FT.)
STREET FRONTAGE AND PARKING LOT PLANTING				
	Platanus racemosa/ Californica Sycamore	17 @ 1,963	-	33,371
	Quercus agrifolia/ Coast Live Oak	-	8 @ 1,925	15,400
	Rhus lancea/ African Sumac	6 @ 962	-	5,772
	Fraxinus velutina/ Velvet Ash	5 @ 380	3 @ 190	2,470
	Olea europaea/ Fruitless Olive	5 @ 962	-	4,810
		TOTAL TREE SHADE		61,823
		TOTAL SURFACE AREA		69,233
		SHADE AREA REQUIRED		34,616
		SHADE AREA PROVIDED BY PORTE COCHERE		720
		TOTAL SHADE PROVIDED		62,543
		PERCENT SHADE		90%

PARKING LOT PERVIOUS SURFACE CALCULATIONS

TOTAL PARKING LOT AREA	90,639 SF
TOTAL PERVIOUS AREA AT PARKING, INCLUDING LANDSCAPE	37,788 SF
PERCENT PERVIOUS	41.7%

- 1 street frontage planting in caltrans right-of-way
- 2 site entry drive
- 3 parking lot planting
- 4 hotel entry planting
- 5 pool court
- 6 relocated trailhead access
- 7 existing chaparral to remain
- 8 salvia river
- 9 debris basin below
- 10 utility easement
- 11 existing trees to remain
- 12 existing oak to remain
- 13 permeable pavers
- 14 trash & recycling receptacles
- 15 dog waste pick-up sign, bags, and container
- 16 directional signage for trailhead parking
- 17 trailhead monument sign

IRRIGATION SYSTEMS SHALL BE DESIGNED AND INSTALLED AS FOLLOWS:

1. EQUIPMENT:
 - 1.1. ANTI-DRAIN VALVES, INTEGRAL, UNDER THE HEAD, OR IN-LINE ANTI-DRAIN VALVES SHALL BE INSTALLED AS NEEDED TO PREVENT LOW HEAD DRAINAGE.
 - 1.2. AUTOMATIC CONTROL VALVES, DIFFERENT HYDROZONES SHALL BE IRRIGATED BY SEPARATE VALVES.
 - 1.3. CONTROLLERS, AUTOMATIC CONTROL SYSTEMS SHALL BE REQUIRED FOR ALL IRRIGATION SYSTEMS AND MUST BE ABLE TO ACCOMMODATE ALL ASPECTS OF THE DESIGN. AUTOMATIC CONTROLLERS SHALL BE DIGITAL, HAVE MULTIPLE PROGRAMS, MULTIPLE CYCLES (START-TIMES), AND HAVE SENSOR INPUT CAPABILITIES.
 - 1.4. RAIN SENSOR DEVICES, RAIN SENSING OVERRIDE DEVICES SHALL BE REQUIRED WHERE APPROPRIATE ON ALL IRRIGATION SYSTEMS.
 - 1.5. SOIL MOISTURE SENSORS, SOIL MOISTURE SENSING DEVICES SHALL BE CONSIDERED WHERE APPROPRIATE, SUCH AS TURF AREAS.
 - 1.6. SPRINKLER HEADS, SPRINKLER HEADS SHALL BE SELECTED FOR PROPER AREA COVERAGE, APPLICATION RATE, OPERATING PRESSURE AND ADJUSTMENT CAPABILITY. SPRINKLERS SHALL HAVE MATCHED PRECIPITATION AND APPLICATION RATES WITHIN EACH CONTROL VALVE CIRCUIT.
 - 1.7. WATER METERS, SEPARATE LANDSCAPE WATER METERS OR SUB-METERS SHALL BE INSTALLED FOR ALL PROJECTS WITH LANDSCAPE AND NON-LANDSCAPE AREAS. LANDSCAPE SUB-METERS, IF USED, SHALL BE PURCHASED, INSTALLED AND MAINTAINED BY THE OWNER.
2. RUNOFF AND OVERSPRAY. ALL IRRIGATION SYSTEMS SHALL BE DESIGNED TO AVOID RUNOFF, LOW HEAD DRAINAGE, OVERSPRAY OR OTHER SIMILAR CONDITIONS WHERE WATER FLOWS OR DREIFTS ONTO ADJACENT PROPERTY, NON-IRRIGATED AREAS, PEDESTRIAN WALKWAYS, ROADWAYS OR STRUCTURES.
3. System Performance—Turf Areas. Irrigation systems for turf areas must achieve a minimum distribution uniformity of:
 - 3.1. Seventy-five (75) percent for areas of one acre or more of contiguous area;
 - 3.2. Sixty-five (65) percent for areas less than one acre but greater than five thousand (5,000) square feet of contiguous area; and,
 - 3.3. Fifty-five (55) percent for areas less than five thousand (5,000) square feet of contiguous area.
4. Water Efficient Systems. Irrigation systems shall be designed to reduce overall water consumption, including irrigation water consumption. The following methods should be utilized in designing water efficient irrigation systems.
 - 4.1. Group plants with similar water requirements, and to match these plant groupings with precipitation heads and emitters.
 - 4.2. Use drip irrigation for trees, shrub beds and areas of groundcover to eliminate evaporation losses.
 - 4.3. Choose low-volume, low-angle sprinklers for lawn areas.
 - 4.4. Select heads that fit the size and shape of the areas to be watered. Program automatic controllers for night irrigation to reduce water losses due to evaporation and wind drift.
 - 4.5. Select controllers with adjustable watering schedules and moisture sensors to account for seasonal variations, and calibrate them during installation.
 - 4.6. Place three to five inches of mulch on planting beds each spring to minimize evaporation.
 - 4.7. Install sub-grade drip irrigation systems to conserve water.



Site Planting Plan

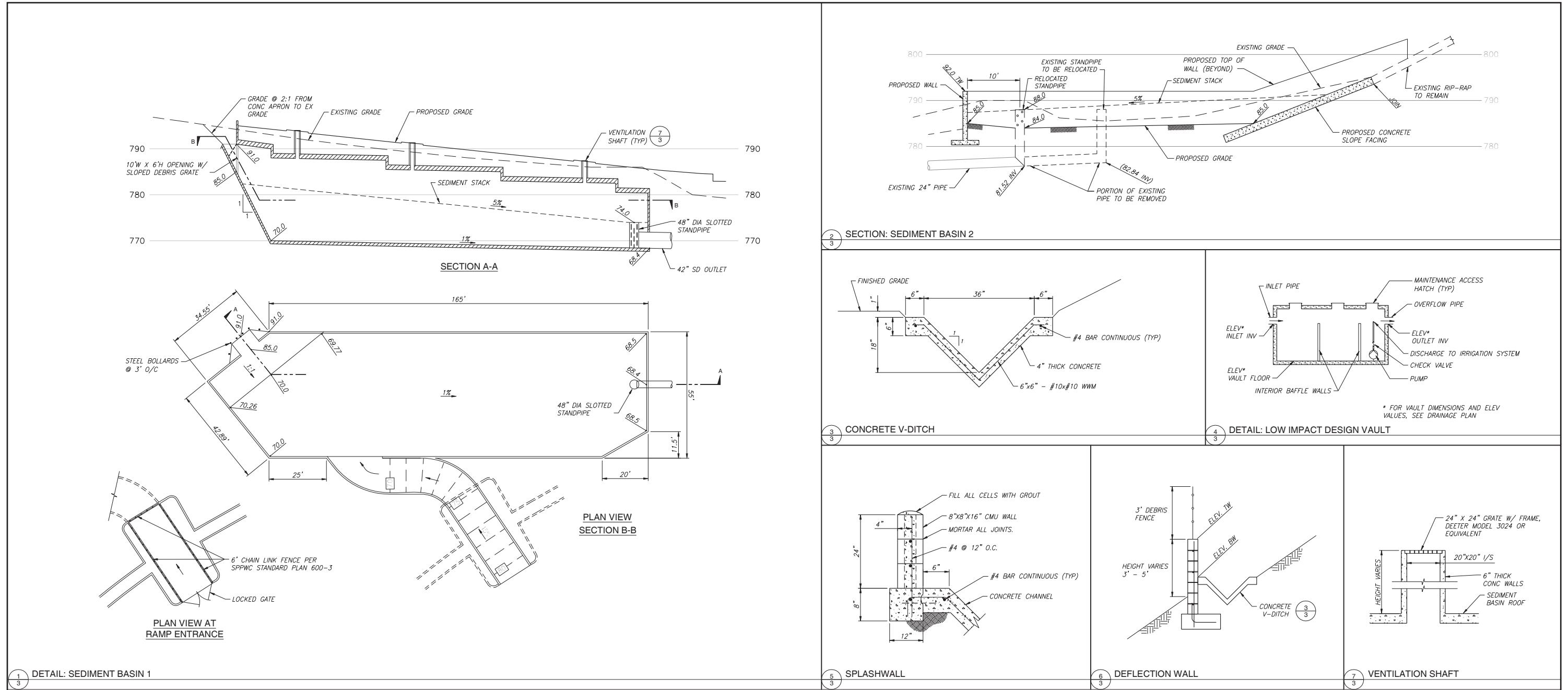

Drainage Details

ENVIRONMENTAL FACTORS POTENTIALLY AFFECTED

The environmental factors checked below would be potentially affected by this project, involving at least one impact that is “Potentially Significant” or “Potentially Significant Unless Mitigation Incorporated” as indicated by the checklist on the following pages.

- | | | |
|--|---|---|
| <input type="checkbox"/> Aesthetics | <input type="checkbox"/> Agriculture and Forest Resources | <input type="checkbox"/> Air Quality |
| <input checked="" type="checkbox"/> Biological Resources | <input type="checkbox"/> Cultural Resources | <input type="checkbox"/> Geology/Soils |
| <input type="checkbox"/> Greenhouse Gas Emissions | <input type="checkbox"/> Hazards & Hazardous Materials | <input type="checkbox"/> Hydrology/Water Quality |
| <input type="checkbox"/> Land Use/Planning | <input type="checkbox"/> Mineral Resources | <input type="checkbox"/> Noise |
| <input type="checkbox"/> Population/Housing | <input type="checkbox"/> Public Services | <input type="checkbox"/> Recreation |
| <input type="checkbox"/> Transportation/Traffic | <input type="checkbox"/> Utilities/Service Systems | <input type="checkbox"/> Mandatory Findings of Significance |



DETERMINATION

On the basis of this initial evaluation:

- I find that the proposed project COULD NOT have a significant effect on the environment, and a NEGATIVE DECLARATION will be prepared.
- I find that although the proposed project could have a significant effect on the environment, there will not be a significant effect in this case because revisions in the project have been made by or agreed to by the project proponent. A MITIGATED NEGATIVE DECLARATION will be prepared.
- I find that the proposed project MAY have a significant effect on the environment, and an ENVIRONMENTAL IMPACT REPORT is required.
- I find that the proposed project MAY have a “potentially significant impact” or “potentially significant unless mitigated” impact on the environment, but at least one effect (1) has been adequately analyzed in an earlier document pursuant to applicable legal standards, and (2) has been addressed by mitigation measures based on the earlier analysis as described on attached sheets. An ENVIRONMENTAL IMPACT REPORT is required, but it must analyze only the effects that remain to be addressed.
- I find that although the proposed project could have a significant effect on the environment, because all potential significant effects (a) have been analyzed adequately in an earlier EIR or NEGATIVE DECLARATION pursuant to applicable standards, and (b) have been avoided or mitigated pursuant to that earlier EIR or NEGATIVE DECLARATION, including revisions or mitigation measures that are imposed upon the proposed project, nothing further is required.

Signature

Michael Klein

Printed Name

Date

Planner
Title



ENVIRONMENTAL CHECKLIST

	Potentially Significant Impact	Potentially Significant Unless Mitigation Incorporated	Less than Significant Impact	No Impact
I. AESTHETICS				
-- Would the Project:				
a) Have a substantial adverse effect on a scenic vista?	<input type="checkbox"/>	<input type="checkbox"/>	<input checked="" type="checkbox"/>	<input type="checkbox"/>
b) Substantially damage scenic resources, including, but not limited to, trees, rock outcroppings, and historic buildings within a state scenic highway?	<input type="checkbox"/>	<input type="checkbox"/>	<input checked="" type="checkbox"/>	<input type="checkbox"/>
c) Substantially degrade the existing visual character or quality of the site and its surroundings?	<input type="checkbox"/>	<input type="checkbox"/>	<input checked="" type="checkbox"/>	<input type="checkbox"/>
d) Create a new source of substantial light or glare which would adversely affect day or nighttime views in the area?	<input type="checkbox"/>	<input type="checkbox"/>	<input checked="" type="checkbox"/>	<input type="checkbox"/>

a) Would the project have a substantial adverse effect on a scenic vista?

b) Would the project substantially damage scenic resources, including, but not limited to, trees, rock outcroppings, and historic buildings within a state scenic highway?

c) Would the project substantially degrade the existing visual character or quality of the site and its surroundings?

As shown on the City’s Land Use Map and Zoning Map, the project site is located within a locally designated Ventura Freeway Scenic Corridor and the Las Virgenes Gateway. The project site is located approximately 350 feet southeast of the 101 Freeway, which is not officially designated as a state scenic highway; however, it is identified as eligible for designation as a state scenic highway (Caltrans, 2014). The 101 Freeway is also a locally designated scenic highway in the City’s 2030 General Plan. The site is also visible from Las Virgenes Road, which the 2030 General Plan identifies as a Scenic Corridor. No City-designated significant ridgelines are located on the project site. However, Figure III-4 of the City’s 2030 General Plan shows a significant ridgeline east of the project site. As a result, the proposed hotel would be located between Las Virgenes Road and the significant ridgeline.

As shown in Figures 5a through 5e, the project site is currently vacant, but was previously graded. The component of the project site that is Rondell Street is a dirt lot adjacent to Las Virgenes Road that is used for parking. As shown in Figures 5a and 5b, commercial land uses are located to the south and west, the 101 Freeway is located to the north, and open space is immediately east of the project site.

The proposed project would be most prominently visible from vehicles traveling along the 101 Freeway and Las Virgenes Road. The project site would not be visible from the eastern portions of Agoura Road, which conveys traffic and/or pedestrians directly onto the Las Virgenes Road



Scenic Corridor. The visual character of the portion of the site immediately facing Las Virgenes Road would be directly influenced by the proposed hotel and the proposed conversion of Rondell Street to parking and landscaping since these facilities would be oriented toward Las Virgenes Road. The existing Las Virgenes Road elevation ranges from approximately 770 feet above mean sea level (amsl) along the project frontage near the proposed hotel location, to 790 feet amsl near the northern parking area. The proposed building pad elevation for the hotel is approximately 785 feet amsl (see Figure 3, Site Plan). Some parking would be located at the same elevation as the hotel, while the remainder would be below the hotel on Rondell Street. Figures 8a and 8b show photo simulations of the hotel from across and along Las Virgenes Road.

Ornamental and native landscaping would be used throughout the project area and generally would be concentrated around the perimeter of the hotel and parking areas and along the project's Las Virgenes Road frontage. As a result, the proposed landscaping would screen portions of the development area from the view corridors.

The proposed hotel would be visible from the 101 Freeway. However, the proposed project would be largely concentrated on an existing graded pad and would not alter the site's natural topography. The proposed hotel would be partially obscured by the existing urban development present between the 101 Freeway and Las Virgenes Road. Nadel Residential and Commercial, Inc. prepared a Sight Line Study for the proposed project (see Appendix B). As shown in Figures 9a through 9e, the Sight Line Study demonstrates that the proposed project would not block views of the significant ridgeline east of the project site from the 101 Freeway or from Las Virgenes Road. The proposed on-site grading and development would extend as high as 845 feet amsl, while the significant ridgeline located east of the subject site is approximately 1,200 feet amsl. Additionally, because the hotel is setback from Las Virgenes Road by approximately 140 feet, views from Las Virgenes Road to the significant ridgeline would not be obscured.

Foreground views of the project site are primarily available from Las Virgenes Road along the project's frontage. These foreground views of the project site would be altered as part of project development. Figures 8a, 8b, 9a and 9b show the extent to which the proposed structure, roadway improvements, and ornamental landscaping would dominate the foreground view along the project's Las Virgenes Road frontage. Although this change may be considered adverse by some viewers, it is considered less than significant because the proposed project maintains views of the designated ridgelines above the project site. Moreover, the project is designed to conform to the City of Calabasas 2030 General Plan, which specifically envisioned a mixture of business and retail uses constructed within the project site (Figure IX-2 of the Calabasas 2030 General Plan). The proposed project would concentrate site development within the southern portions of the property adjacent to the gas station. The project's development intensity would be comparable to that of adjacent commercial development located south of the project site and west of Las Virgenes Road, although the project would be four stories and surrounding development is generally one to three stories. Furthermore, as shown on Figures 6, 8a and 8b, the proposed project would expand the areas of Las Virgenes Road dedicated to streetscape landscaping improvements. The proposed improvements would include enhanced entry landscaping and the planting of large specimen trees along the project's Las Virgenes Road frontage and throughout the interior portions of the development area. This is consistent with the objectives and policies contained with the Community Design Element of Calabasas 2030 General Plan, the Las Virgenes Gateway Master Plan, and Las Virgenes Road Corridor Design Plan.



Commercial gas stations and other commercial retail uses are located directly south and west of the project site. A mixture of single-family and multi-family and commercial developments are also located southwest of the project site. The gas station and commercial retail areas generally include one to three story buildings with varying architectural/aesthetic qualities. The proposed project would include construction of a commercial hotel in close proximity to these uses. The project's proposed Monterey, Spanish, and Santa Barbara styled architecture would meet or exceed the level of quality found in the nearby commercial retail uses (see Figures 8a, 8b, 10a, and 10b). In addition, 1.3 acres of the eastern and northern portions of the project site, which include the site's natural hillsides, would remain undeveloped. This would create an open space buffer around the proposed project and would also help to preserve the visual character and available scenic views of the surrounding public open space lands, most of which are owned by the Mountains Recreation and Conservation Authority. This is consistent with the goals and policies established by the City of Calabasas 2030 General Plan Open Space Element, Community Design Element, and the Scenic Corridor Development Guidelines.

The project would minimize potential impacts to visual character and quality by locating architecturally compatible structures adjacent to existing commercial development, using native and non-invasive ornamental landscape plant materials to blend building forms, and by not altering the site's natural topography. Although the proposed project would alter the visual quality and character of the site, it would not substantially degrade the area and has been designed in conformance with the overall West Village development concept described in the 2030 General Plan Community Design Element. In addition, the project site does not include historic buildings or rock outcroppings and the proposed project would not remove any existing trees present on the project site; therefore, the project would not substantially damage scenic resources within an eligible state scenic highway. As a result, the proposed project's visual impacts would be less than significant. The impacts of the proposed project on views from the Juan Bautista de Anza Historic Trail are described in detail in Section V, *Cultural Resources*.

Estimated buildout of vacant lands in Calabasas would continue to incrementally change the visual character of Calabasas by adding a total of 306 residential dwellings (includes single and multi-family building types) and approximately 484,767 square feet of commercial development over the General Plan planning period (City of Calabasas, 2008b and 2013). However, only the Paxton Calabasas project and the proposed Canyon Oaks project, both of which are south of the project site, would be developed along the east side of Las Virgenes Road, thereby having the potential to alter views from within the Las Virgenes Road and U.S. 101 Scenic Corridors (City of Calabasas, website, "Projects, Plans & Reports in the City of Calabasas"). The visual impacts of the proposed project, the Paxton Calabasas project, the Canyon Oaks project, and other planned development projects were anticipated by City of Calabasas 2030 General Plan and the General Plan EIR. The Paxton Calabasas project, the Canyon Oaks project, and the proposed project are generally consistent with the intent of the 2030 General Plan, which is to focus development along the east side of Las Virgenes Road while preserving the views of the significant ridgelines to the east. In addition, the parcels east of the project site are designated Open Space - Resource Protection (OS-RP), preventing future development adjacent to the project site from extending further up slope. This would prevent further cumulative changes to the visual character of this portion of the Las Virgenes Road corridor.

LESS THAN SIGNIFICANT IMPACT





Looking east from intersection of U.S. 101 Southbound Off-Ramp and Las Virgenes Road





Looking southeast from across Las Virgenes Road

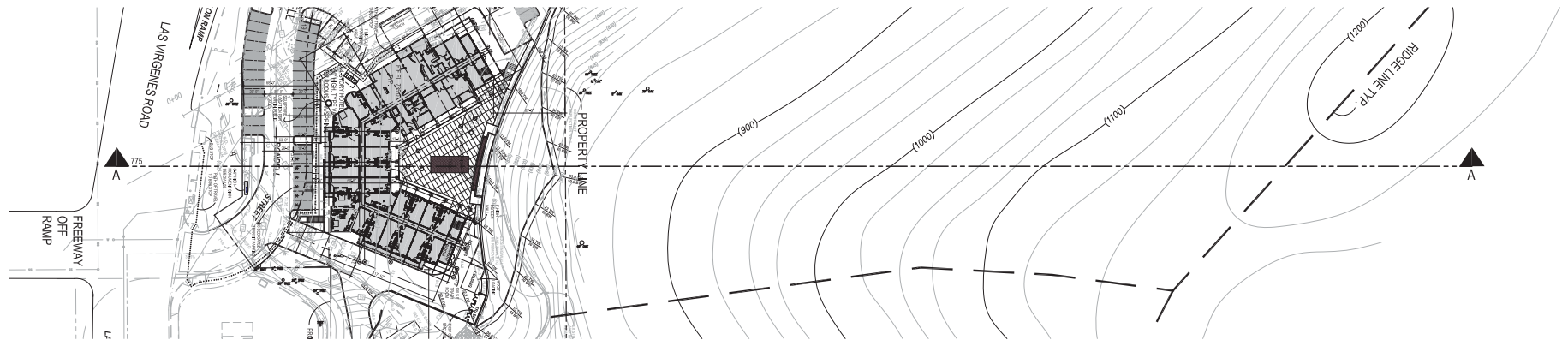

Sight Line Plan for Section A-A

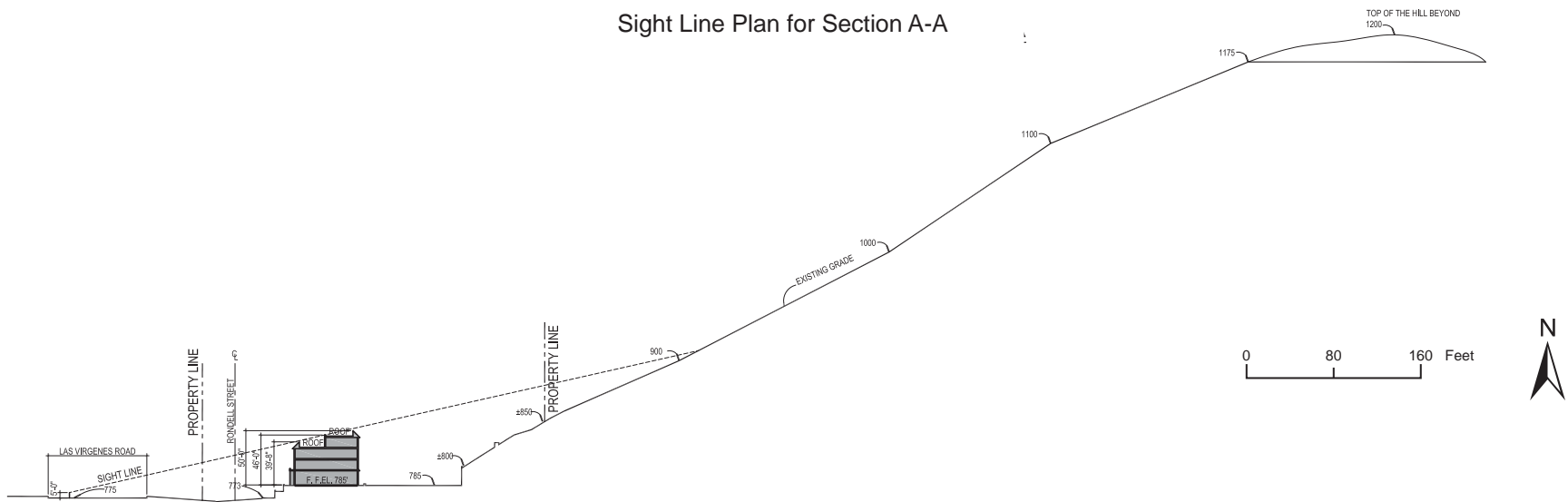

Section A-A

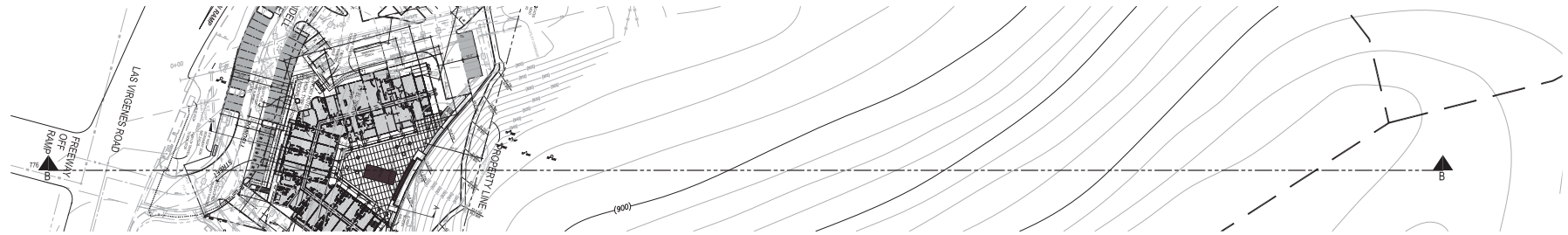

Sight Line Plan for Section B-B

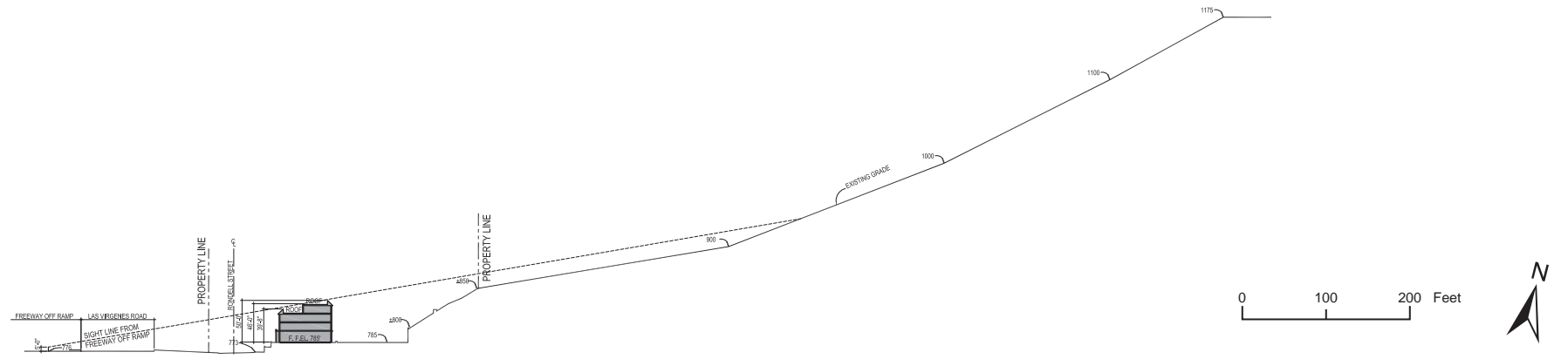

Section B-B

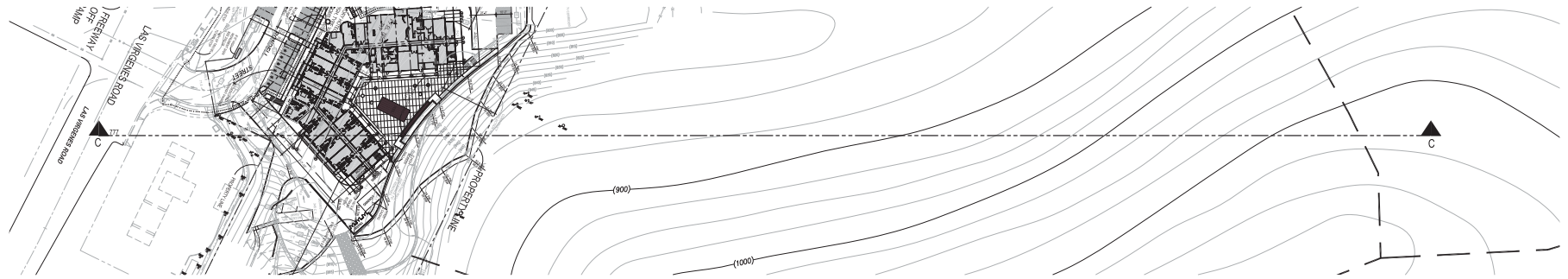

Sight Line Plan for Section C-C

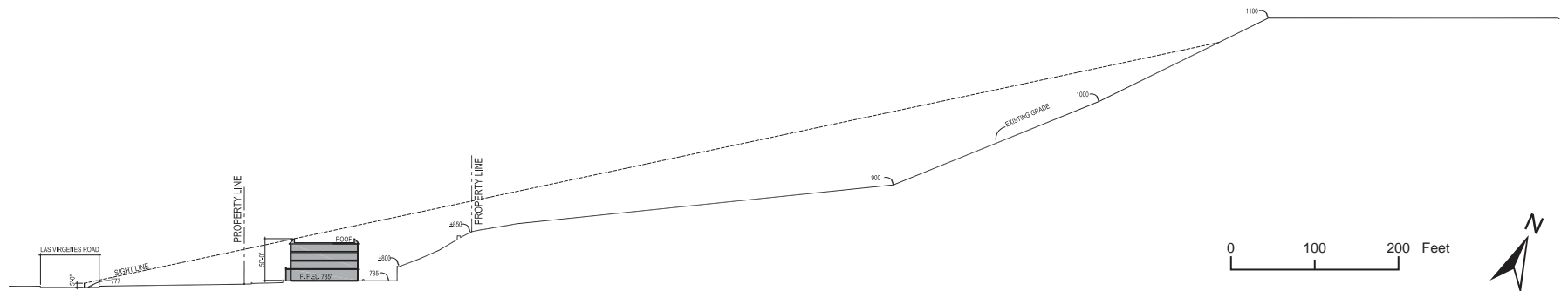

Section C-C

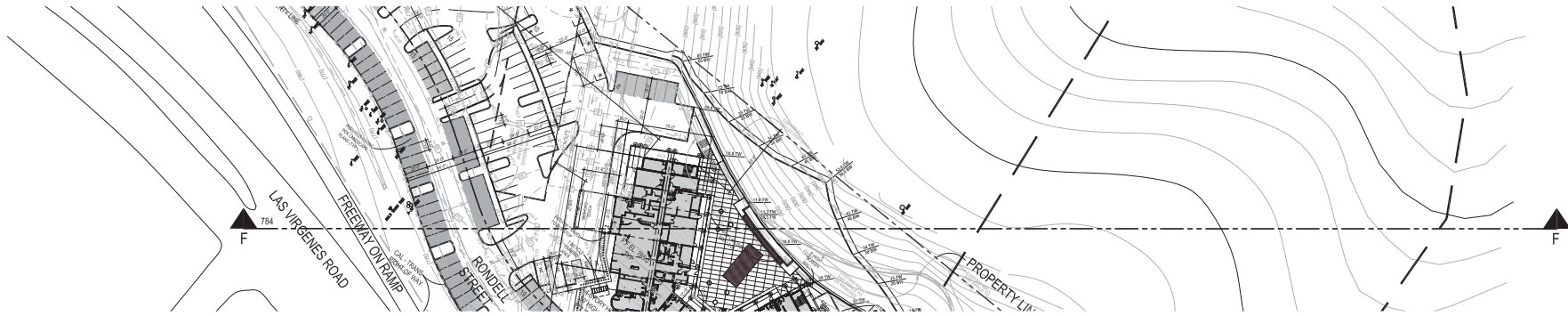

Sight Line Plan for Section F-F

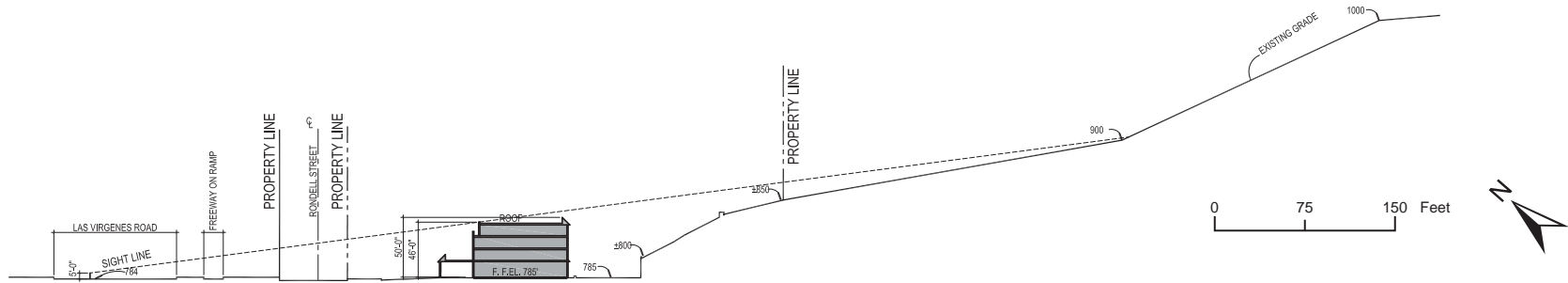

Section F-F

Sight Line Plan For Section F-F

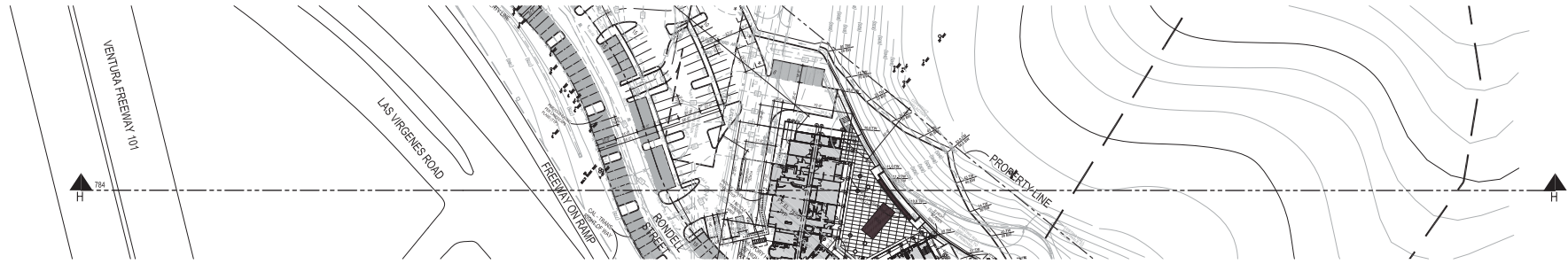

Sight Line Plan for Section H-H

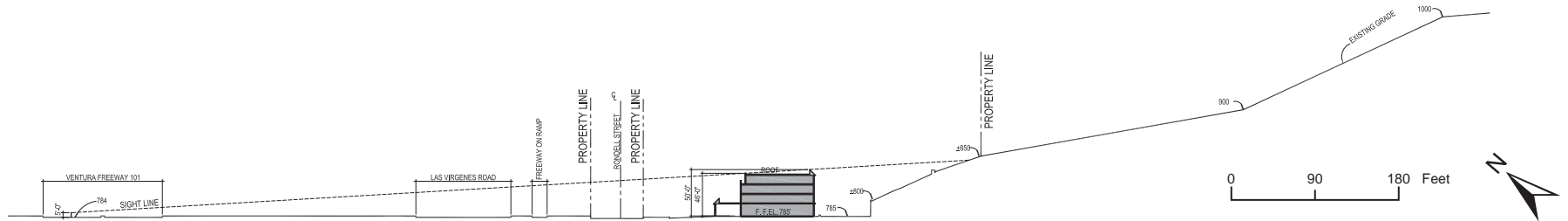

Section H-H



Project Elevations



East Elevation
 Scale: 1" = 25'



South Elevation
 Scale: 1" = 25'

Project Elevations

d) Would the project create a new source of substantial light or glare which would adversely affect day or nighttime views in the area?

The proposed new building would be a new light source from interior and exterior illumination. Potential light sources would include parking lot lighting, building mounted lighting, pathway lighting and roadway lighting. These light sources could create both an increase in ambient light levels and new sources of glare, which is created by direct or reflected visual exposure to the light source.

The proposed hotel and parking areas would be located adjacent to Las Virgenes Road in an area already developed with existing commercial land uses; therefore, it would not substantially increase the levels of light and glare beyond those already experienced in the area. The nearest residences are at the Shea Colony, approximately 800 feet south of the project site and light spillover from the proposed project would not adversely affect these residences.

Furthermore, the City's Land Use and Development Code regulates lighting via Section 17.27 of the CMC, also referred to as the "Dark Skies Ordinance." The City requires that "all exterior lights and illuminated signs be designed, located, installed and directed in such a manner as to prevent objectionable light at (and glare across) the property lines and glare at any location on or off the property" (City of Calabasas, Development Code Section 17.27.020.f). This is generally accomplished through the use of shielding and directional lighting methods and through the use of low level pedestrian and perimeter landscape lighting. The City's condition of approval system requires the applicant for any project to submit evidence that the proposed work would comply with the code (City of Calabasas, Development Code Section 17.27.040).

As shown in Figure 11, Site Photometrics, light from the proposed project would not exceed 0.1 footcandles on the eastern and southern site boundaries. Light levels on the southeastern site boundary adjacent to the gas station would range from less than 0.1 to 5.2 footcandles, on the northern boundary with the 101 Freeway light levels range from less than 0.1 to 3.5 footcandles, and on the western boundary with the Las Virgenes Road frontage light levels range from less than 0.1 to 6.0 footcandles. The review process would limit the light and glare effects on adjacent uses and would protect the character of the City of Calabasas from inappropriate levels of night lighting. Pursuant to this ordinance, architectural and lighting plans would be reviewed prior to the issuance of building permits to ensure that all proposed light fixtures would not substantially impact neighboring properties. Lighting impacts would therefore be less than significant.

LESS THAN SIGNIFICANT IMPACT



This page intentionally left blank.



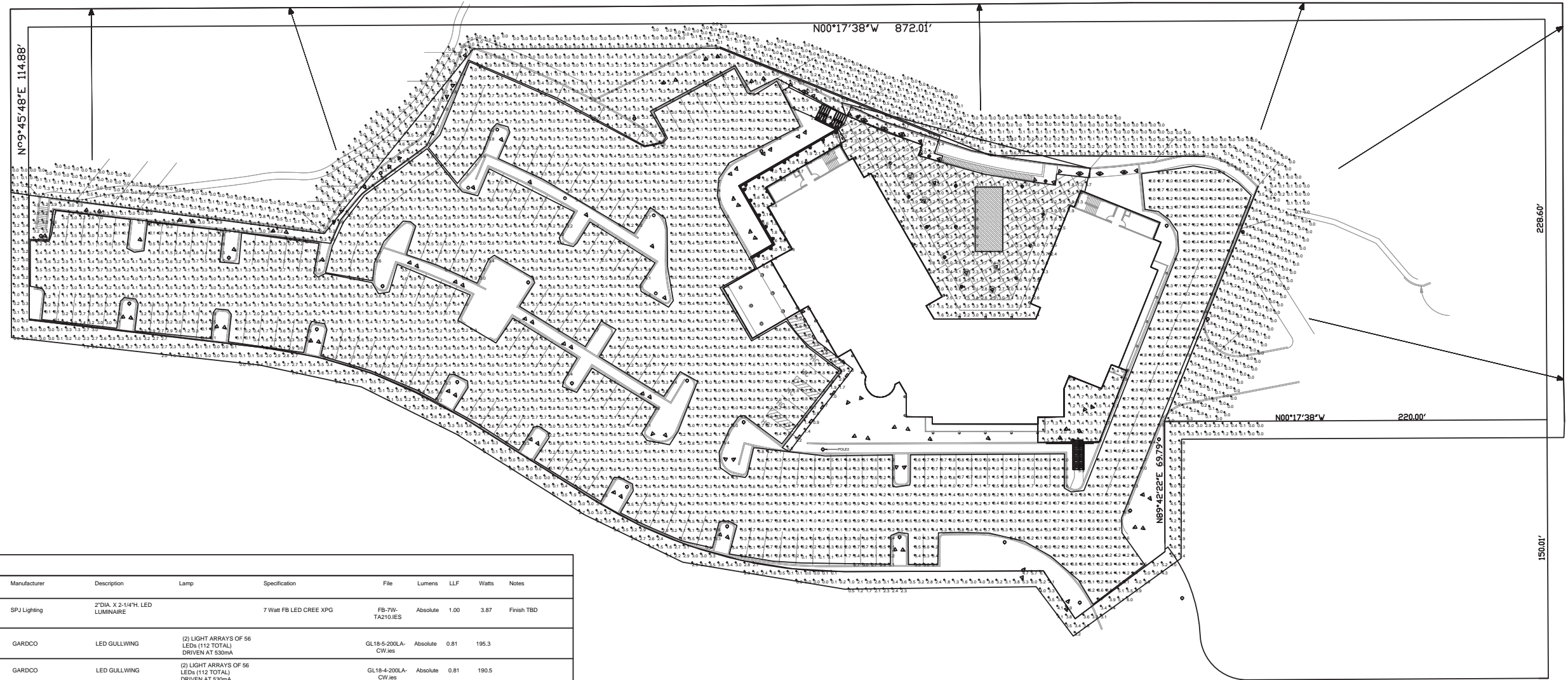

Symbol	Label	Qty	Catalog Number	Manufacturer	Description	Lamp	Specification	File	Lumens	LLF	Watts	Notes
▲	TR-LT	127	FB-7W-TA210	SPJ Lighting	ZIDA, X 2-1/4\"/>							
○	POLE1	29	GL18-5-200LA-CW	GARDCO	LED GULLWING	(2) LIGHT ARRAYS OF 56 LEDs (112 TOTAL) DRIVEN AT 530mA		GL18-5-200LA-CW.ies	Absolute	0.81	195.3	
○	POLE2	1	GL18-4-200LA-CW	GARDCO	LED GULLWING	(2) LIGHT ARRAYS OF 56 LEDs (112 TOTAL) DRIVEN AT 530mA		GL18-4-200LA-CW.ies	Absolute	0.81	190.5	
□	PATH	9	SS-LED-#23-A-24-DEGREES; PS-LED-#23-A-24-DEGREES; SS-LED-#23-A-24-DEGREES	BK Lighting	CAST METAL WALL MOUNTING HOUSING, ONE ADJUSTABLE OPTICAL ASSEMBLY	THREE 2.5-WATT WHITE LIGHT EMITTING DIODES (LEDS) EACH WITH CLEAR HEMISPHERICAL INTEGRAL PLASTIC LENS, LEDS AIMED 24-DEGREES BELOW THE HORIZON.	PS-LED-E22-AB-BZP-B-PP-T	PS-LED-#23-A-24\"/>				
⊞	STEP	23	SS-LED-#23-A-24-DEGREES; PS-LED-#23-A-24-DEGREES; SS-LED-#23-A-24-DEGREES	SPJ Lighting	CAST METAL WALL MOUNTING HOUSING, ONE ADJUSTABLE OPTICAL ASSEMBLY	THREE 2.5-WATT WHITE LIGHT EMITTING DIODES (LEDS) EACH WITH CLEAR HEMISPHERICAL INTEGRAL PLASTIC LENS, LEDS AIMED 24-DEGREES BELOW THE HORIZON.	SPJ18-03-MBR-2W-125-2700K	PS-LED-#23-A-24\"/>				
⊙	POLES	8	LCS-2341	TEKA Illumination	CYLINDRICAL DIFFUSE BRASS COLORED METAL POST TOP FITTER	ONE 150-WATT CLEAR T-6 METAL HALIDE, VERTICAL BASE-DOWN POSITION.		ITL50905.IES	3000	1.00	13	
○	WALL	38	WBLED18Y (ROUND WALL MOUNT) / BLEDR18Y (42\"/>									
⊙	A	6	DOM8 LED 1500L 35K		8\"/>							

*ALL PARKING POLE LIGHTS ARE TO BE "POLE1" UNLESS OTHERWISE NOTED.

Description	Symbol	Avg	Max	Min	Max/Min	Avg/Min	Avg/Max
COURTYARD	+	3.1 fc	5.5 fc	0.7 fc	7.9:1	4.4:1	0.6:1
GATHERING	+	1.3 fc	2.7 fc	0.0 fc	N/A	N/A	0.5:1
Outside of Parking Area	+	1.7 fc	5.2 fc	0.0 fc	N/A	N/A	0.3:1
Outside Property Line	+	2.4 fc	6.1 fc	0.0 fc	N/A	N/A	0.4:1
Parking	+	3.3 fc	8.2 fc	0.1 fc	82.0:1	33.0:1	0.4:1
WALKWAY/STAIRS	+	1.9 fc	5.8 fc	0.0 fc	N/A	N/A	0.3:1

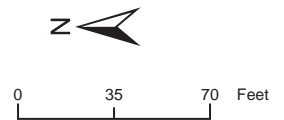

Site Photometrics

Potentially Significant Impact	Potentially Significant Unless Mitigation Incorporated	Less than Significant Impact	No Impact
--------------------------------------	--	------------------------------------	--------------

II. AGRICULTURE AND FOREST RESOURCES

-- In determining whether impacts to agricultural resources are significant environmental effects, lead agencies may refer to the California Agricultural Land Evaluation and Site Assessment Model (1997) prepared by the California Dept. of Conservation as an optional model to use in assessing impacts on agriculture and farmland. In determining whether impacts to forest resources, including timberland, are significant environmental effects, lead agencies may refer to information compiled by the California Department of Forestry and Fire Protection regarding the state's inventory of forest land, including the Forest and Range Assessment Project and the Forest Legacy Assessment Project; and forest carbon measurement methodology provided in Forest Protocols adopted by the California Air Resources Board. -- Would the project:

a) Convert Prime Farmland, Unique Farmland, Farmland of Statewide Importance (Farmland), as shown on the maps prepared pursuant to the Farmland Mapping and Monitoring Program of the California Resources Agency, to non-agricultural use?	<input type="checkbox"/>	<input type="checkbox"/>	<input type="checkbox"/>	<input checked="" type="checkbox"/>
b) Conflict with existing zoning for agricultural use, or a Williamson Act contract?	<input type="checkbox"/>	<input type="checkbox"/>	<input type="checkbox"/>	<input checked="" type="checkbox"/>
c) Conflict with existing zoning for, or cause rezoning of, forest land (as defined in Public Resources Code Section 12220(g)), timberland (as defined by Public Resources Code Section 4526), or timberland zoned Timberland Production (as defined by Government Code Section 51104(g))?	<input type="checkbox"/>	<input type="checkbox"/>	<input type="checkbox"/>	<input checked="" type="checkbox"/>
d) Result in the loss of forest land or conversion of forest land to non-forest use?	<input type="checkbox"/>	<input type="checkbox"/>	<input type="checkbox"/>	<input checked="" type="checkbox"/>
e) Involve other changes in the existing environment which, due to their location or nature, could result in conversion of Farmland, to non-agricultural use?	<input type="checkbox"/>	<input type="checkbox"/>	<input type="checkbox"/>	<input checked="" type="checkbox"/>



- a) Would the project convert Prime Farmland, Unique Farmland, Farmland of Statewide Importance (Farmland), as shown on the maps prepared pursuant to the Farmland Mapping and Monitoring Program of the California Resources Agency, to non-agricultural use?
- b) Would the project conflict with existing zoning for agricultural use, or a Williamson Act contract?
- c) Would the project conflict with existing zoning for, or cause rezoning of, forest land (as defined in Public Resources Code Section 12220(g)), timberland (as defined by Public Resources Code Section 4526), or timberland zoned Timberland Production (as defined by Government Code Section 51104(g))?
- d) Would the project result in the loss of forest land or conversion of forest land to non-forest use?
- e) Would the project involve other changes in the existing environment which, due to their location or nature, could result in conversion of Farmland, to non-agricultural use?

Neither the project site nor surrounding areas contain any agricultural resources, farmland, forest land, or timberland. Consequently, the proposed project would have no effect on Prime Farmland, Unique Farmland, or Farmland of Statewide Importance (California Division of Land Resource Protection, 2014). Calabasas does not include land zoned for agricultural or forest land, nor are any lands within the City under a Williamson Act contract. The proposed project would have no impact upon agricultural or forest resources.

NO IMPACT

	Potentially Significant Impact	Potentially Significant Unless Mitigation Incorporated	Less than Significant Impact	No Impact
III. AIR QUALITY				
-- Would the project:				
a) Conflict with or obstruct implementation of the applicable air quality plan?	<input type="checkbox"/>	<input type="checkbox"/>	<input checked="" type="checkbox"/>	<input type="checkbox"/>
b) Violate any air quality standard or contribute substantially to an existing or projected air quality violation?	<input type="checkbox"/>	<input type="checkbox"/>	<input checked="" type="checkbox"/>	<input type="checkbox"/>
c) Result in a cumulatively considerable net increase of any criteria pollutant for which the project region is non-attainment under an applicable federal or state ambient air quality standard (including releasing emissions which exceed quantitative thresholds for ozone precursors)?	<input type="checkbox"/>	<input type="checkbox"/>	<input checked="" type="checkbox"/>	<input type="checkbox"/>
d) Expose sensitive receptors to substantial pollutant concentrations?	<input type="checkbox"/>	<input type="checkbox"/>	<input checked="" type="checkbox"/>	<input type="checkbox"/>
e) Create objectionable odors affecting a substantial number of people?	<input type="checkbox"/>	<input type="checkbox"/>	<input checked="" type="checkbox"/>	<input type="checkbox"/>



The project site is within the South Coast Air Basin (the Basin), which is under the jurisdiction of the South Coast Air Quality Management District (SCAQMD). As the local air quality management agency, the SCAQMD is required to monitor air pollutant levels to ensure that state and federal air quality standards are met and, if they are not met, to develop strategies to meet the standards. Depending on whether or not the standards are met or exceeded, the Basin is classified as being in “attainment” or “nonattainment.” The health effects associated with criteria pollutants upon which attainment of state and federal air quality standards is measured are described in Table 2.

Table 2
Health Effects Associated with Criteria Pollutants

Pollutant	Adverse Effects
Ozone	(1) Short-term exposures: pulmonary function decrements and localized lung edema in humans and animals and risk to public health implied by alterations in pulmonary morphology and host defense in animals; (2) long-term exposures: risk to public health implied by altered connective tissue metabolism and altered pulmonary morphology in animals after long-term exposures and pulmonary function decrements in chronically exposed humans; (3) vegetation damage; and (4) property damage.
Carbon monoxide (CO)	(1) Aggravation of angina pectoris and other aspects of coronary heart disease; (2) decreased exercise tolerance in persons with peripheral vascular disease and lung disease; (3) impairment of central nervous system functions; and (4) possible increased risk to fetuses.
Nitrogen dioxide (NO ₂)	(1) Potential to aggravate chronic respiratory disease and respiratory symptoms in sensitive groups; (2) risk to public health implied by pulmonary and extra-pulmonary biochemical and cellular changes and pulmonary structural changes; and (3) contribution to atmospheric discoloration.
Sulfur dioxide (SO ₂)	(1) Bronchoconstriction accompanied by symptoms that may include wheezing, shortness of breath, and chest tightness during exercise or physical activity in persons with asthma.
Suspended particulate matter (PM ₁₀)	(1) Excess deaths from short-term and long-term exposures; (2) excess seasonal declines in pulmonary function, especially in children; (3) asthma exacerbation and possibly induction; (4) adverse birth outcomes including low birth weight; (5) increased infant mortality; (6) increased respiratory symptoms in children such as cough and bronchitis; and (7) increased hospitalization for both cardiovascular and respiratory disease (including asthma). ^a
Suspended particulate matter (PM _{2.5})	(1) Excess deaths from short- and long-term exposures; (2) excess seasonal declines in pulmonary function, especially in children; (3) asthma exacerbation and possibly induction; (4) adverse birth outcomes, including low birth weight; (5) increased infant mortality; (6) increased respiratory symptoms in children, such as cough and bronchitis; and (7) increased hospitalization for both cardiovascular and respiratory disease, including asthma. ^a

Source: U.S. Environmental Protection Agency, *What are the Six Common Air Pollutants?* website <http://www.epa.gov/oaqps001/urbanair/>, accessed March 10, 2015.

^aMore detailed discussions on the health effects associated with exposure to suspended particulate matter can be found in the following documents: Office of Environmental Health Hazard Assessment, *Particulate Matter Health Effects and Standard Recommendations*, www.oehha.ca.gov/air/toxic_contaminants/PM10notice.html#may, May 9, 2002; and EPA, *Air Quality Criteria for Particulate Matter*, October 2004.

The South Coast Air Basin (Basin), in which the project site is located, is a non-attainment area for the federal standards for ozone, PM_{2.5}, and lead, and the state standards for ozone, PM₁₀, PM_{2.5}, NO₂ and lead. This non-attainment status is a result of several factors, the primary ones being the naturally adverse meteorological conditions that limit the dispersion and diffusion of pollutants, the limited capacity of the local airshed to eliminate air pollutants, and the number, type, and density of emission sources within the Basin.



Because the Basin currently exceeds several state and federal ambient air quality standards, the SCAQMD is required to implement strategies to reduce pollutant levels to recognized acceptable standards. To accomplish this requirement, the SCAQMD has adopted an Air Quality Management Plan (AQMP) that provides a strategy for the attainment of state and federal air quality standards.

The SCAQMD recommends the use of quantitative thresholds to determine the significance of temporary construction-related pollutant emissions and project operations. These thresholds are shown in Table 3.

Table 3
SCAQMD Air Quality Significance Thresholds

Pollutant	Mass Daily Thresholds	
	Operation Thresholds	Construction Thresholds
NO _x	55 lbs/day	100 lbs/day
ROG ¹	55 lbs/day	75 lbs/day
PM ₁₀	150 lbs/day	150 lbs/day
PM _{2.5}	55 lbs/day	55 lbs/day
SO _x	150 lbs/day	150 lbs/day
CO	550 lbs/day	550 lbs/day
Lead	3 lbs/day	3 lbs/day

Source: SCAQMD, <http://www.aqmd.gov/ceqa/handbook/signthres.pdf>, March 2011.

¹ Reactive Organic Gases (ROG) are formed during combustion and evaporation of organic solvents. ROG are also referred to as Volatile Organic Compounds (VOC).

The SCAQMD has also developed Localized Significance Thresholds (LSTs). LSTs were devised in response to concerns regarding the exposure of individuals to criteria pollutants in local communities. LSTs represent the maximum emissions from a project that will not cause or contribute to an air quality exceedance of the most stringent applicable federal or state ambient air quality standard at the nearest sensitive receptor, taking into consideration ambient concentrations in each source receptor area (SRA), project size, and distance to the sensitive receptor. However, LSTs only apply to emissions within a fixed stationary location, including idling emissions during both project construction and operation. LSTs have been developed for NO_x, CO, PM₁₀ and PM_{2.5}. LSTs are not applicable to mobile sources such as cars on a roadway (SCAQMD, revised July 2008). As such, LSTs for operational emissions do not apply to onsite development since the majority of emissions would be generated by cars on roadways.

LSTs have been developed for emissions within areas up to five acres in size, with air pollutant modeling recommended for activity within larger areas. The SCAQMD provides lookup tables for project sites that measure one, two, or five acres. The proposed project involves an approximately 5-acre construction area. The project site is located in Source Receptor Area 6 (SRA-6, West San Fernando Valley). LSTs for construction on a 5-acre site in SRA-6 are shown in Table 4. LSTs are provided for receptors at a distance of approximately 660 and 1,640 feet from the project site boundary. The nearest residences are at the Shea Colony approximately 800 feet south of the project site. According to the SCAQMD, the use of LSTs is voluntary, to be implemented at the discretion of local agencies.



Table 4
SCAQMD LSTs for Construction

Pollutant	Allowable emissions from a 5-acre site in SRA-6 by receptor distances	
	660 feet	1,640 feet
Gradual conversion of NO _x to NO ₂	250	313
CO	3,871	9,271
PM ₁₀	84	181
PM _{2.5}	26	96

Source: SCAQMD, website <http://www.aqmd.gov/docs/default-source/ceqa/handbook/localized-significance-thresholds/appendix-c-mass-rate-lst-look-up-tables.pdf?sfvrsn=2>, October 2009.

a) *Would the project conflict with or obstruct implementation of the applicable air quality plan?*

Vehicle use, energy consumption, and associated air pollutant emissions are directly related to population growth. A project may be inconsistent with the AQMP if it would generate population, housing or employment growth exceeding the forecasts used in the development of the AQMP. The 2012 AQMP was developed using Southern California Association of Governments’ (SCAG) population forecasts. SCAG produces projections of regional population, which form the basis for growth projection in SCAG’s 2012 Regional Transportation Plan-Sustainable Communities Strategy (RTP-SCS). SCAG’s growth forecast projects a population of 24,400 for Calabasas in 2035, an increase of 457 from the estimated 2013 population of 23,943 (California Department of Finance, 2014).

As discussed in Section XIII, *Population and Housing*, the proposed project would not directly increase the population because it does not include residential uses, but may indirectly increase the population by 62 residents, if all new employees relocated to the area. The current City population is approximately 23,943, according to the most recent (2014) California Department of Finance estimate. Therefore, although most employees are expected to be drawn from the local workforce, the proposed project could result in a citywide population of approximately 24,005 persons, if all the employees moved into the City from elsewhere. The level of population growth associated with the proposed project falls within the population growth for Calabasas anticipated in SCAG’s long-term population forecasts. Therefore, the project would not conflict with the population forecasts contained in the 2012 AQMP and the proposed project’s impacts would be less than significant.

The South Coast Air Basin is a non-attainment area for the federal standards for ozone, PM_{2.5} and lead and the state standards for ozone, PM₁₀, PM_{2.5}, NO₂ and lead. Any growth within the Los Angeles metropolitan area would contribute to existing exceedances of ambient air quality standards when taken as a whole with existing development. SCAQMD’s project-specific and cumulative significance thresholds are the same (SCAQMD, August 2003). Projects that exceed the



project-specific significance thresholds are considered by the SCAQMD to be cumulatively considerable (SCAQMD, August 2003). Conversely, projects that do not exceed the project-specific thresholds are not considered to be cumulatively significant (SCAQMD, August 2003). As discussed under “Construction Emissions” and “Long-Term Emissions,” the proposed project would result in an increase in temporary and long-term daily operation emissions; however, emissions would not exceed the SCAQMD thresholds. The project site is adjacent to the proposed Canyon Oaks project and construction of both projects could overlap. However, because the proposed project would not generate emissions that exceed the SCAQMD’s construction, LST, and operational thresholds and the project is consistent with the AQMP, the project’s contribution to cumulative air quality impacts would not be cumulatively considerable.

LESS THAN SIGNIFICANT IMPACT

b) Would the project violate any air quality standard or contribute substantially to an existing or projected air quality violation?

c) Would the project result in a cumulatively considerable net increase of any criteria pollutant for which the project region is non-attainment under an applicable federal or state ambient air quality standard (including releasing emissions which exceed quantitative thresholds for ozone precursors)?

d) Would the project expose sensitive receptors to substantial pollutant concentrations?

Emissions generated by the proposed project would include temporary construction emissions and long-term operational emissions. Emissions are quantified below and compared to SCAQMD significance thresholds, described in more detail above.

Construction Emissions

Project construction would generate temporary air pollutant emissions. These impacts are associated with fugitive dust (PM₁₀ and PM_{2.5}) and exhaust emissions from heavy construction vehicles, in addition to reactive organic gases (ROG) that would be released during the drying phase upon application of architectural coatings.

Emissions associated with the proposed project were estimated using the California Emissions Estimator Model (CalEEMod) version 2013.2.2.

Grading, excavation, hauling, and site preparation would involve the largest use of heavy equipment and generation of fugitive dust. For the purposes of modeling, it was assumed that construction of the proposed project would comply with SCAQMD Rule 403, which identifies measures to reduce fugitive dust and is required to be implemented at all construction sites located within the Basin. Therefore, the following conditions would be required to reduce fugitive dust in compliance with SCAQMD Rule 403 and were included in CalEEMod for the site preparation and grading phases of construction.

- 1. **Minimization of Disturbance.** Construction contractors shall minimize the area disturbed by clearing, grading, earth moving, or excavation operations to prevent excessive dust generation.*



2. **Soil Treatment.** *Construction contractors shall treat all graded and excavated material, exposed soil areas, and active portions of the construction site, including unpaved on-site roadways to minimize fugitive dust. Treatment shall include, but not necessarily be limited to, periodic watering, application of environmentally safe soil stabilization materials, and/or roll compaction as appropriate. Watering shall occur as necessary, and at least twice daily, preferably in the late morning and after work is completed for the day.*
3. **Soil Stabilization.** *Construction contractors shall monitor all graded and/or excavated inactive areas of the construction site daily for dust stabilization. Soil stabilization methods, such as water and roll compaction, and environmentally safe dust control materials, shall be applied to portions of the construction site that are inactive for over four days. If no further grading or excavation operations are planned for the area, the area shall be periodically treated with environmentally safe dust suppressants to prevent excessive fugitive dust.*
4. **No Grading During High Winds.** *Construction contractors shall stop all clearing, grading, earth moving, and excavation operations during periods of high winds (20 miles per hour or greater, as measured continuously over a one-hour period).*
5. **Street Sweeping.** *Construction contractors shall sweep all on-site driveways and adjacent streets and roads at least once per day, preferably at the end of the day, if visible soil material is carried over to adjacent streets and roads.*

It was also assumed that construction of the proposed project would comply with SCAQMD Rule 1113 regarding the use of low-volatile organic compound (VOC) architectural coatings and that construction equipment used would comply with current U.S. Environmental Protection Agency (EPA) and California Air Resources Board (ARB) Tier 3 standards for off-road diesel engines. Construction was estimated to occur over approximately 13 months between April 2016 and May 2017. Complete CalEEMod results and assumptions can be viewed in Appendix C. Table 5 summarizes the estimated maximum daily emissions of pollutants during construction assuming implementation of the above conditions in compliance with SCAQMD regulations. The SCAQMD or LST thresholds would not be exceeded. Therefore, temporary air quality impacts associated with project construction would be less than significant.



Table 5
Estimated Construction Maximum Daily Air Pollutant Emissions

	Maximum Daily Emissions (lbs/day)				
	ROG	NO _x	CO	PM ₁₀	PM _{2.5}
2016 Maximum Daily Emissions (On-site and Off-site) ^a	11.5	39.4	49.6	13.4	8.0
2017 Maximum Daily Emissions (On-site and Off-site) ^a	12.2	28.8	43.5	2.7	1.9
SCAQMD Thresholds	75	100	550	150	55
Threshold Exceeded?	No	No	No	No	No
2016 Maximum Daily Emissions (On-site Only) ^b	10.4	19.5	23.4	9.1	5.4
2017 Maximum Daily Emissions (On-site Only) ^c	10.4	14.2	17.8	0.9	0.9
Local Significance Thresholds (LSTs) at 660 feet ^c	N/A	250	3,871	84	26
Threshold Exceeded?	n/a	No	No	No	No

Source: Calculations were made in CalEEMod.

^a See Table 2.1 “Overall Construction-Mitigated” of winter emissions CalEEMod worksheets in Appendix C. Maximum Daily Emissions include both on-site and off-site emissions.

^b See Tables under 3.0 Construction Detail in CalEEMod worksheets in Appendix C.

^c LST’s only include on-site emissions. LSTs for a 5-acre site in SRA-6, see Table 4

Long-Term Emissions

Long-term emissions associated with project operation, as shown in Table 6, would include emissions from vehicle trips (mobile sources), natural gas and electricity use (energy sources), and landscape maintenance equipment, consumer products and architectural coating associated with onsite development (area sources).

Emissions during operation of the proposed project would not exceed SCAQMD thresholds for any criteria pollutant. Therefore, air quality impacts associated with project operation would be less than significant.



**Table 6
 Estimated Project Operational Emissions**

Sources	Estimated Emissions (lbs/day)					
	ROG	NO _x	CO	PM ₁₀	PM _{2.5}	SO _x
Area	3.1	<0.01	0.03	<0.01	<0.01	<0.01
Energy	0.1	0.5	0.4	0.04	0.04	<0.01
Mobile	3.2	7.8	31.1	5.4	1.5	0.08
Total Emissions (lbs/day)	6.3	8.3	31.5	5.4	1.5	0.08
SCAQMD Thresholds	55	55	550	150	55	150
Threshold Exceeded?	No	No	No	No	No	No

Source: Calculations were made in CalEEMod. See Table 2.2 "Unmitigated Operational" in CalEEMod winter emissions worksheets in Appendix C.

Note: numbers may not add up due to rounding.

LESS THAN SIGNIFICANT IMPACT

e) Would the project create objectionable odors affecting a substantial number of people?

The proposed project would involve construction of a hotel. This use is not included on Figure 5-5, *Land Uses Associated with Odor Complaints*, of the 1993 SCAQMD CEQA Air Quality Handbook. Diesel exhaust may be noticeable during some construction activities. However, the proposed project would not generate objectionable odors affecting a substantial number of people and construction would be temporary in nature; therefore, impacts would be less than significant.

LESS THAN SIGNIFICANT IMPACT

	Potentially Significant Impact	Potentially Significant Unless Mitigation Incorporated	Less than Significant Impact	No Impact
--	---------------------------------------	---	-------------------------------------	------------------

IV. BIOLOGICAL RESOURCES

-- Would the project:

- a) Have a substantial adverse effect, either directly or through habitat modifications, on any species identified as a candidate, sensitive, or special status species in local or regional plans, policies, or regulations, or by the California Department of Fish and Wildlife or U.S. Fish and Wildlife Service?

<input type="checkbox"/>	<input checked="" type="checkbox"/>	<input type="checkbox"/>	<input type="checkbox"/>
--------------------------	-------------------------------------	--------------------------	--------------------------



	Potentially Significant Impact	Potentially Significant Unless Mitigation Incorporated	Less than Significant Impact	No Impact
--	--------------------------------------	--	------------------------------------	--------------

IV. BIOLOGICAL RESOURCES

-- Would the project:

- | | | | | |
|--|--------------------------|-------------------------------------|-------------------------------------|-------------------------------------|
| b) Have a substantial adverse effect on any riparian habitat or other sensitive natural community identified in local or regional plans, policies, or regulations, or by the California Department of Fish and Wildlife or U.S. Fish and Wildlife Service? | <input type="checkbox"/> | <input type="checkbox"/> | <input checked="" type="checkbox"/> | <input type="checkbox"/> |
| c) Have a substantial adverse effect on federally protected wetlands as defined by Section 404 of the Clean Water Act (including, but not limited to, marsh, vernal pool, coastal, etc.) through direct removal, filling, hydrological interruption, or other means? | <input type="checkbox"/> | <input type="checkbox"/> | <input checked="" type="checkbox"/> | <input type="checkbox"/> |
| d) Interfere substantially with the movement of any native resident or migratory fish or wildlife species or with established native resident or migratory wildlife corridors, or impede the use of native wildlife nursery sites? | <input type="checkbox"/> | <input checked="" type="checkbox"/> | <input type="checkbox"/> | <input type="checkbox"/> |
| e) Conflict with any local policies or ordinances protecting biological resources, such as a tree preservation policy or ordinance? | <input type="checkbox"/> | <input type="checkbox"/> | <input checked="" type="checkbox"/> | <input type="checkbox"/> |
| f) Conflict with the provisions of an adopted Habitat Conservation Plan, Natural Community Conservation Plan, or other approved local, regional, or state habitat conservation plan? | <input type="checkbox"/> | <input type="checkbox"/> | <input type="checkbox"/> | <input checked="" type="checkbox"/> |

a) Would the project have a substantial adverse effect, either directly or through habitat modifications, on any species identified as a candidate, sensitive, or special status species in local or regional plans, policies, or regulations, or by the California Department of Fish and Wildlife or U.S. Fish and Wildlife Service?

A reconnaissance level biological survey was performed by a Rincon Consultants Biologist on March 6, 2015. Table 7 below shows plant and wildlife species observed on the project site at the time of the survey. None of the species observed are identified as candidate, sensitive, or special status species in local or regional plans, or by the California Department of Fish and Wildlife or U.S. Fish and Wildlife Service. The biological resources observed on-site are typical of those found on properties with a disturbance history. Examples of known disturbances on this property include fire, development, and grading. The project site is dominated by ruderal vegetation, but also contains sage scrub and oak savannah habitat types as well as a variety of trees, some of which have been planted. Common ruderal vegetation observed includes fiddleneck, black mustard, redstem filaree, cheeseweed, white horehound, Bermuda buttercup,



milk thistle, and yellow sweetclover. Common sage scrub vegetation observed includes coyote brush, California sagebrush, field bindweed, buckwheat, sawtooth goldenbush, lupine, phacelia, purple sage, and blue elderberry. Common oak savannah vegetation observed includes valley oak, coast live oak, and a variety of grass species (*Bromus* sp.).

**Table 7
 Plant and Wildlife Species Observed**

Scientific Name	Common Name	Native	Family
Plant Species			
<i>Artemisia californica</i>	California sagebrush	Yes	Asteraceae
<i>Amsinckia</i> sp.	Fiddleneck	Yes	Boraginaceae
<i>Baccharis pilularis</i>	Coyote brush	Yes	Asteraceae
<i>Brassica nigra</i>	Black mustard	No	Brassicaceae
<i>Bromus</i> sp.	Variety of grass species	Yes/No	Poaceae
<i>Convolvulus arvensis</i>	Field bindweed	No	Convolvulaceae
<i>Dichelostemma capitatum</i> ssp. <i>capitatum</i>	Blue dicks	Yes	Themidaceae
<i>Eriogonum</i> sp.	Buckwheat	Yes	Polygonaceae
<i>Erodium borty</i>	Broadleaf filaree	No	Geraniaceae
<i>Erodium cicutarium</i>	Redstem filaree	No	Geraniaceae
<i>Eschscholzia californica</i>	California poppy	Yes	Papaveraceae
<i>Hazardia</i> sp.	Goldenbush sp.	Yes	Asteraceae
<i>Juglans californica</i> var. <i>californica</i>	Southern Calif. black walnut	Yes	Juglandaceae
<i>Lupinus</i> sp.	Lupine	Yes	Fabaceae
<i>Malva parviflora</i>	Cheeseweed	No	Malvaceae
<i>Marrubium vulgare</i>	White horehound	No	Lamiaceae
<i>Medicago polymorpha</i>	Common burclover	No	Fabaceae
<i>Melilotus indicus</i>	Annual yellow sweetclover	No	Fabaceae
<i>Oxalis pes-caprae</i>	Bermuda buttercup	No	Oxalidaceae
<i>Pentagramma triangularis</i> ssp. <i>triangularis</i>	Goldenback fern	Yes	Pteridaceae
<i>Phacelia distans</i>	Phacelia	Yes	Boraginaceae
<i>Pinus</i> sp.	Pine sp.	No	Pinaceae
<i>Quercus agrifolia</i> var. <i>agrifolia</i>	Coast live oak	Yes	Fagaceae
<i>Quercus lobata</i>	Valley Oak	Yes	Fagaceae
<i>Rhus integrifolia</i>	Lemonade berry	Yes	Anacardiaceae
<i>Salix lasiolepis</i> var. <i>lasiolepis</i>	Arroyo willow	Yes	Salicaceae
<i>Salvia leucophylla</i>	Purple sage	Yes	Lamiaceae
<i>Sambucus mexicana</i>	Blue elderberry	Yes	Caprifoliaceae
<i>Schinus terebenthifolius</i>	Brazilian pepper tree	No	Anacardiaceae
<i>Silybum marianum</i>	Milk thistle	No	Asteraceae
Wildlife Species			
Reptiles			
<i>Sceloporus occidentalis</i>	Western fence lizard	Yes	
Birds			
<i>Haemorhous mexicanus</i>	House finch	Yes	
<i>Larus occidentalis</i>	Western gull	Yes	
<i>Psaltriparus minimus</i>	Bushtit	Yes	
<i>Corvus brachyrhynchos</i>	American crow	Yes	
<i>Chamaea fasciata</i>	Wrentit	Yes	
Mammals			
<i>Spermophilus beecheyi</i>	California ground squirrel	Yes	
<i>Sylvilagus bachmani</i>	Brush rabbit	Yes	



A target list of special-status plant and animal species that could potentially occur within the vicinity of the project site was developed based on a search of CDFW's California Natural Diversity Database (CNDDDB) records occurring within a 5-mile radius of the project site on March 13, 2015. Fourteen special-status plant and 18 animal species are known to occur within the vicinity of the project site. However, no Federally- or State-listed or any other special-status plant or animal species have been observed on-site and none are known to occur or have occurred on-site. In addition, the USFWS' Critical Habitat Portal (available at <http://criticalhabitat.fws.gov/crithab/>) also provides online service for information regarding threatened and endangered species final Critical Habitat designation across the U.S. According to the CNDDDB and the Critical Habitat Portal, three critical habitats are mapped within a five-mile radius of the project site for the following species: Braunton's milk vetch, Lyon's pentachaeta, and California red-legged frog. No critical habitat is mapped within the project site.

Species listed under the federal Endangered Species Act or California Special Concern Species were not observed on the project site and are not expected to occur as the project site is located in a generally developed area and has been previously graded and disturbed. No Federally-designated critical habitat for listed wildlife species is mapped within the project site, and no critical habitat would be affected by the project. Therefore, the proposed project would not have a substantial adverse effect on any species identified as a candidate, sensitive, or special-status species in local or regional plans or by the California Department of Fish and Wildlife (CDFW) or U.S. Fish and Wildlife Service (USFWS).

The larger trees and shrubs within the project site provide potentially suitable nesting habitat for a variety of bird species that are afforded protection under the federal Migratory Bird Treaty Act (MBTA - 16 United State Code Section 703-711) and California Fish and Game Code (CFG) Section 3503. The proposed project has the potential to impact migratory and other bird species if construction activities occur during the nesting season, which is typically February 1 through August 31. Construction-related disturbance may result in nest abandonment or premature fledging of the young. The proposed project could result in potentially significant impacts unless sufficient mitigation is incorporated. Therefore, Mitigation Measure BIO-1 would be required to reduce any potential impacts to migratory and resident nesting bird species to a less than significant level.

- BIO-1 Nesting Birds.** If vegetation clearing or other soil disturbance is to be initiated during the bird breeding season (February 1 through August 31), pre-construction/grading surveys shall be conducted by a qualified biologist. Surveys shall be conducted no more than one to two weeks prior to the initiation of clearance/construction work. If any active *non-raptor* bird nests are found, a suitable buffer area (varying from 250-300 feet), depending on the particular species found, shall be established from the nest, and that area shall be avoided until the nest becomes inactive (vacated). If any active *raptor* bird nests are found, a suitable buffer area of typically 250-500 feet from the nest shall be established, and that area shall be avoided until the nest becomes inactive (vacated). The limits of construction to avoid a nest shall be established in the field with flagging and stakes



or construction fencing. Construction personnel shall be instructed on the sensitivity of the area by a qualified biologist hired by the project proponent and endorsed by the City of Calabasas. Encroachment into buffers around active nests must be conducted at the discretion of a qualified biologist. The applicant shall record the results of the recommended protective measures described above to document compliance with applicable State and federal laws pertaining to the protection of nesting birds. Prior to the completion of construction, the applicant shall submit the above referenced documentation to the Community Development Director.

Implementation of mitigation measure BIO-1 would reduce potential impacts to sensitive or listed nesting bird species to a less than significant level.

POTENTIALLY SIGNIFICANT UNLESS MITIGATION INCORPORATED

b) Would the project have a substantial adverse effect on any riparian habitat or other sensitive natural community identified in local or regional plans, policies, or regulations, or by the California Department of Fish and Wildlife or U.S. Fish and Wildlife Service?

e) Would the project conflict with any local policies or ordinances protecting biological resources, such as a tree preservation policy or ordinance?

As discussed above, the biological resources observed on-site are typical of those found on properties with a disturbance history. Riparian habitat and other sensitive natural communities are not present on the project site. The project site contains both valley oak and coast live oak trees. The City of Calabasas Oak Tree Ordinance sets forth the policy of the City to require the preservation of all healthy oak trees unless reasonable and conforming use of the property justifies the removal, cutting, pruning, and/or encroachment into the Protected Zone of an oak tree. The City's Oak Tree Protection and Preservation Policy and guidelines were established to recognize oak trees as significant and valuable aesthetic and ecological resources. The Oak Tree Ordinance requires completion of an Oak Tree Report by an International Society of Arboriculture (ISA) Certified arborist for projects involving impacts to oak trees. An Oak Tree Report (see Appendix A) was prepared by L. Newman Design Group, Inc. and peer-reviewed by a certified arborist with Rincon Consultants. Nine oak trees are present on or near the project site boundaries. Five trees are *Quercus agrifolia* (coast live oak) and four trees are *Quercus lobata* (valley oak). No oak trees would be removed due to the project and no above-ground (branch) pruning is anticipated; however, the project would encroach into the protected zone of three oak trees and root pruning is anticipated. Therefore, the project would require an Oak Tree Permit per the Calabasas Municipal Code, which includes the submittal of an oak tree report prepared in accordance with the City's Oak Tree Preservation and Protection Guidelines. The project would be required to adhere to the measures outlined in the Oak Tree Report's Oak Tree Preservation Program in order to obtain an Oak Tree Permit. Measures include, but are not limited to, fencing along the protected zones of oak trees, hand trenching within the zones, root pruning in compliance with ISA pruning standards, and monitoring by a certified arborist of any work within the protected zones (see Appendix A). Therefore, impacts would be less than significant.



LESS THAN SIGNIFICANT IMPACT

c) Would the project have a substantial adverse effect on federally protected wetlands as defined by Section 404 of the Clean Water Act (including, but not limited to, marsh, vernal pool, coastal, etc.) through direct removal, filling, hydrological interruption, or other means?

No riparian habitats were observed on the project site. A retaining wall runs along the east side of the project site at the foot of the hill and may serve as a water channel. This retaining wall runs north to south and at the southern end turns into a water channel v-ditch before connecting with a concrete spillway. A total of four additional drainage v-ditch channels are located at the southern end of the project site. An additional concrete drainage channel runs along the east side of the Mobil gas station property and empties out on the southwest corner of the project site. However, no riparian habitat is associated with these channels, as all are concrete lined. As discussed in Section X, *Hydrology and Water Quality*, a Stormwater Pollution Prevention Plan (SWPPP) would be prepared for the proposed project. The SWPPP would specify Best Management Practices (BMPs) to be implemented by the contractor during construction to minimize stormwater runoff to the concrete channel and downstream impacts to water quality. In addition, the proposed project would be required to comply with the water quality requirements of the current Los Angeles County Municipal Separate Storm Sewer System (MS4) permit, which requires that the amount of runoff from the site must be the same before and after construction of a project, and the Los Angeles County Low Impact Development (LID) Ordinance (L.A. County Code, Title 12, Ch. 12.84 and Title 22, Ch. 22.52), which requires all infiltration water quality devices to be sized using the 0.75 inch storm or the 85th percentile storm, whichever is greater. Compliance with the MS4 permit and LID requirements would reduce on-site erosion from vegetated areas. Additionally, the project site is not located on or in the vicinity of a federally protected wetland (FWS wetlands Mapper, 2014). Therefore, the proposed project would have a less than significant impact.

LESS THAN SIGNIFICANT IMPACT

d) Would the project interfere substantially with the movement of any native resident or migratory fish or wildlife species or with established native resident or migratory wildlife corridors, or impede the use of native wildlife nursery sites?

Wildlife movement can be limited by roads, railroads, dams, canals, urban development, and agriculture. Fragmentation of large habitat areas into small, isolated segments has been shown to generally reduce biological diversity, eliminate disturbance-sensitive species, restrict genetic flow between populations of organisms, and may eventually lead to the loss of local floral or faunal assemblages. Wildlife corridors and habitat linkages are landscape elements that reduce the potential loss in local and regional biological diversity. City of Calabasas 2030 General Plan Conservation Element policies were created to ensure that new developments maintain the biotic habitat value of riparian areas, habitat linkages, and other special-status biological habitats. Policy IV-2 in the Conservation Element notes that loss of habitat linkages is unacceptable. Land uses that retain connectivity between moderate-sized patches of similar-value habitats across an entire parcel, and outward beyond the boundaries, provide better habitat linkage than do designs that set aside larger, but non-contiguous, areas of habitat.



The project site is adjacent to the regionally mapped Santa Monica – Sierra Madre Connection and portions of the project site that are outside of the project’s development footprint are identified as Los Angeles County Significant Ecological Areas (SEAs) (California Fish and Wildlife BIOS database, website accessed March 13, 2015; City of Calabasas 2030 General Plan Conservation Element, 2008; County of Los Angeles, GIS-NET3). The project site is located within the western portion the City of Calabasas mapped Wildlife Linkage and Corridor, as defined in the City of Calabasas 2030 General Plan Conservation Element. The 2030 General Plan envisions the site as a Business-Retail land use and the 2030 General Plan FEIR found that development under the 2030 General Plan would have less than significant impacts to wildlife movement corridors (Impact BIO-4) with implementation of Conservation Element Policies IV-2, which requires new development to maintain the biotic habitat value of habitat linkages and does not allow loss of habitat linkages.

The total width of the mapped corridor at the five-acre project site is approximately one mile (City of Calabasas 2030 General Plan Conservation Element, 2008). The proposed project would develop approximately 3.7 acres of the site. Development would be concentrated on previously disturbed areas of the project site near the frontage on Las Virgenes Road and the southern portion of the project site adjacent to the gas station. The 1.3 acres in the eastern and northern portions of the project site, which include the site’s natural hillsides, would remain undeveloped. The permanently developed area of the project site would be approximately 300 feet wide at the widest point. The project’s 300 foot-wide permanently developed footprint would constrict the City’s mapped 1.0-mile-wide corridor by approximately 6%. As required in Calabasas Municipal Code Section 17.20.100(H) (Fences, Walls and Hedges; Fencing for Wildlife Movement), fencing on the project site must be wildlife friendly. Fencing must be designed to be easily bypassed by all species of wildlife found within the Santa Monica Mountains. Wildlife friendly fencing would provide permeability through and over fencing for access to adjacent habitats and to retain connectivity of the habitats on-site with the habitats off-site.

In addition, the proposed project would introduce lighting and glare. New sources of lighting and glare are required to comply with City standards (Section 17.27.030 of the Calabasas Municipal Code). Because the project is within the City’s Wildlife Linkage and Corridor Area, it must incorporate lighting design features that limit roadway lighting from on-site sources to 0.6 fc on pavement, and sidewalk and bikeway lighting to 0.2 fc on pavement. Compliance with City standards for fencing and lighting in wildlife corridors would reduce impacts from project operation to wildlife movement and connectivity. Nonetheless, the mitigation listed below is necessary to reduce impacts to wildlife linkages and corridors to a less than significant level.

Planned or pending projects in the vicinity of the project site may also impact the western portion of the City of Calabasas Wildlife Linkage and Corridor, such as the Canyon Oaks project located south of the project site. The Canyon Oaks project is approximately 77 acres in size and would be located immediately south of the project site. Cumulatively, the Rondell Oasis Hotel project and the Canyon Oaks project may adversely affect the City of Calabasas Wildlife Linkage and Corridor; however, the proposed project would reduce the 1.0-mile-wide corridor by approximately 6% and its contribution to the cumulative impact to wildlife corridors in the area would not be cumulatively considerable.

POTENTIALLY SIGNIFICANT UNLESS MITIGATION INCORPORATED



Mitigation Measure

The following mitigation measures would reduce impacts to wildlife linkages and corridors to a less than significant level.

BIO-2 Sound Restrictions. Sound amplification equipment shall be shielded from open space areas to reduce effects on wildlife movement. Sound levels shall not exceed an equivalent noise level (Leq) of 65 dBA as measured at the edge of the project site.

Implementation of measure BIO-2 would reduce project impacts to wildlife corridors to a less than significant level.

f) Would the project conflict with the provisions of an adopted Habitat Conservation Plan, Natural Community Conservation Plan, or other approved local, regional, or state habitat conservation plan?

No adopted habitat conservation plans or natural community conservation plans apply in Calabasas (2030 General Plan FEIR, 2008). No impact would occur.

NO IMPACT

	Potentially Significant Impact	Potentially Significant Unless Mitigation Incorporated	Less than Significant Impact	No Impact
--	--------------------------------	--	------------------------------	-----------

V. CULTURAL RESOURCES

-- Would the project:

a) Cause a substantial adverse change in the significance of a historical resource as defined in §15064.5?	<input type="checkbox"/>	<input type="checkbox"/>	<input checked="" type="checkbox"/>	<input type="checkbox"/>
b) Cause a substantial adverse change in the significance of an archaeological resource as defined in §15064.5?	<input type="checkbox"/>	<input type="checkbox"/>	<input checked="" type="checkbox"/>	<input type="checkbox"/>
c) Directly or indirectly destroy a unique paleontological resource or site or unique geologic feature?	<input type="checkbox"/>	<input type="checkbox"/>	<input checked="" type="checkbox"/>	<input type="checkbox"/>
d) Disturb any human remains, including those interred outside of formal cemeteries?	<input type="checkbox"/>	<input type="checkbox"/>	<input checked="" type="checkbox"/>	<input type="checkbox"/>
e) Would the project cause a substantial adverse change in the significance of a tribal cultural resource as defined in Public Resources Code 21074?	<input type="checkbox"/>	<input type="checkbox"/>	<input checked="" type="checkbox"/>	<input type="checkbox"/>



a) Would the project cause a substantial adverse change in the significance of a historical resource as defined in §15064.5?

b) Would the project cause a substantial adverse change in the significance of an archaeological resource as defined in §15064.5?

c) Would the project directly or indirectly destroy a unique paleontological resource or site or unique geologic feature?

d) Would the project disturb any human remains, including those interred outside of formal cemeteries?

e) Would the project cause a substantial adverse change in the significance of a tribal cultural resource as defined in Public Resources Code 21074?

The project site is currently vacant and is not identified as a cultural resource sensitivity area in the General Plan Cultural Resources Element (2008). The project site was also previously graded. A Phase I Cultural Resources Investigation was prepared by McKenna et al. in November 2013 and a Cultural Resources Review was conducted by Historical Environmental Archaeological Research Team (HEART) in April 2011 for the Canyon Oaks property, south of the project site and east of the Agoura Road and Las Virgenes Road intersection. Both studies report no evidence of prehistoric or historic cultural resources, including archaeological, paleontological or other cultural resources on the Canyon Oaks site, which is adjacent to the project site.

There is no evidence that archaeological, paleontological, or tribal cultural resources, or human remains are present onsite. In the unlikely event that such resources are unearthed during construction, applicable regulatory requirements pertaining to the handling and treatment of such resources would be followed. If archaeological, paleontological, or tribal cultural resources are identified, as defined by Sections 2103.2 and 21074 of the Public Resources Code, the site would be required to be treated in accordance with the provisions of Section 21083.2 of the Public Resources Code as appropriate. If human remains are unearthed, State Health and Safety Code Section 7050.5 requires that no further disturbance shall occur until the County Coroner has made the necessary findings as to origin and disposition pursuant to Public Resources Code Section 5097.98. Due to the previous grading of the project site, existing standard monitoring during construction in conformance with current discipline standards, and the findings of recent cultural resource investigations on adjacent properties, impacts of the proposed project on archaeological, paleontological, tribal cultural, and historical resources would be less than significant.

Trailhead access to the Calabasas Historic Trail, also known as the Juan Bautista de Anza Historic Trail, is located 140 feet east of the project site (see Photo 16 in Figure 5d). The trail stretches for 1.4 miles from the east end of Calabasas Road west to Las Virgenes Road, roughly parallel to current Highway 101. This trail would eventually become part of El Camino Real, the road connecting the California Missions. The trail is eligible for historic designation as a historic landscape (City of Calabasas, 2012). Between 1774 and 1776, Juan Bautista de Anza led two overland expeditions from Sonora, Mexico to Alta California. The segment of the Anza Trail that passes through Calabasas has been identified as part of the original route and is part of the Juan Bautista de Anza National Historic Trail, which was designated by Congress in 1990. The



Anza National Historic Trail, including the Calabasas segment, was recognized again by the White House in 2000 as one of 16 Millennium Trails.

Parking for the existing trailhead access, approximately 140 feet east of the project site, is located off of Las Virgenes Road on Rondell Street, which is currently a dirt lot used for parking by many non-trail users. Currently, there is no legal access to the trail because users have to cross private property to reach the trail head. As a result, the proposed project would create trailhead access, dedicate five parking spaces to trailhead parking, and include improvements to the trailhead access, such as trash and recycle receptacles and dog waste pick-up sign, bags, and container. All the improvements would be located on the project site and would enhance the trail, without altering the trail or the landscape around the trail.

Due to the topography, the project site would be visible for approximately 900 feet of the 1.4 mile trail, or approximately 12% of the trail (see photos 17 through 19 in Figure 5e). For the majority of the 900 feet, the proposed hotel would not be visible, but the parking area and trailhead access would be visible. As shown in photos from the trail in Figure 5e, the proposed project would alter the southwestern view from the trail, which includes the dirt lot used for parking (Rondell Street), the previously graded pads of the project site, overhead utility lines, the 101 Freeway, and commercial uses across Las Virgenes Road. The proposed project may increase the developed nature of the view from the trail and increase use of the trail. However, because the view from the trail already includes commercial and residential development similar to the proposed project, this change would not create a detrimental impact to the trail’s eligibility for historic designation as a historic landscape.

LESS THAN SIGNIFICANT IMPACT

	Potentially Significant Impact	Potentially Significant Unless Mitigation Incorporated	Less than Significant Impact	No Impact
VI. GEOLOGY AND SOILS				
-- Would the project:				
a) Expose people or structures to potential substantial adverse effects, including the risk of loss, injury, or death involving:				
i) Rupture of a known earthquake fault, as delineated on the most recent Alquist-Priolo Earthquake Fault Zoning Map issued by the State Geologist for the area or based on other substantial evidence of a known fault?	<input type="checkbox"/>	<input type="checkbox"/>	<input checked="" type="checkbox"/>	<input type="checkbox"/>
ii) Strong seismic ground shaking?	<input type="checkbox"/>	<input type="checkbox"/>	<input checked="" type="checkbox"/>	<input type="checkbox"/>
iii) Seismic-related ground failure, including liquefaction?	<input type="checkbox"/>	<input type="checkbox"/>	<input checked="" type="checkbox"/>	<input type="checkbox"/>



	Potentially Significant Impact	Potentially Significant Unless Mitigation Incorporated	Less than Significant Impact	No Impact
VI. GEOLOGY AND SOILS				
-- Would the project:				
iv) Landslides?	<input type="checkbox"/>	<input type="checkbox"/>	<input checked="" type="checkbox"/>	<input type="checkbox"/>
b) Result in substantial soil erosion or the loss of topsoil?	<input type="checkbox"/>	<input type="checkbox"/>	<input checked="" type="checkbox"/>	<input type="checkbox"/>
c) Be located on a geologic unit or soil that is unstable as a result of the project, and potentially result in on- or off-site landslide, lateral spreading, subsidence, liquefaction, or collapse?	<input type="checkbox"/>	<input type="checkbox"/>	<input checked="" type="checkbox"/>	<input type="checkbox"/>
d) Be located on expansive soil, as defined in Table 1-B of the Uniform Building Code, creating substantial risks to life or property?	<input type="checkbox"/>	<input type="checkbox"/>	<input checked="" type="checkbox"/>	<input type="checkbox"/>
e) Have soils incapable of adequately supporting the use of septic tanks or alternative wastewater disposal systems where sewers are not available for the disposal of wastewater?	<input type="checkbox"/>	<input type="checkbox"/>	<input type="checkbox"/>	<input checked="" type="checkbox"/>

a.i) Expose people or structures to potential substantial adverse effects, including the risk of loss, injury, or death involving rupture of a known earthquake fault, as delineated on the most recent Alquist-Priolo Earthquake Fault Zoning Map issued by the State Geologist for the area or based on other substantial evidence of a known fault?

a.ii) Expose people or structures to potential substantial adverse effects, including the risk of loss, injury, or death involving strong seismic ground shaking?

a.iii) Expose people or structures to potential substantial adverse effects, including the risk of loss, injury, or death involving seismic-related ground failure, including liquefaction?

a.iv) Expose people or structures to potential substantial adverse effects, including the risk of loss, injury, or death involving landslides?

No faults traverse the project site and no active faults have been mapped within Calabasas; however, the City lies within a seismically active region that is prone to occasional earthquakes. According to the Southern California Earthquake Data Center Map (SCEDC), there are nine active faults and four potentially active faults within 25 miles of the City. Like much of California, the project site is subject to groundshaking from seismic activity emanating from a number of faults in the region. In addition, portions of the project site are potentially susceptible to liquefaction and earthquake-induced landslides (2030 General Plan Seismic Hazard Zones Map, 2014). The California Building Code (CBC) and the City of Calabasas Development Code

control building design and construction. Calabasas, along with all of Southern California and the Central Coast, is within Seismic Zone 4, the area of greatest risk and subject to the strictest building standards. New development would conform to the CBC (as amended at the time of permit approval) as required by law, and preparation of a final City-approved geotechnical study and remediation plan would be required prior to project approval. According to GeoSoils Consultants, Inc. and Willdan Engineering, the proposed project would be safe from the hazards of landslide, settlement, or slippage and would not adversely affect the stability of the adjacent properties nor be adversely affected by adjacent properties (Willdan Engineering and GeoSoils Consultants, Inc., 2015). Compliance with applicable standards during construction of the proposed project would reduce the potential impact to less than significant and no mitigation would be required.

LESS THAN SIGNIFICANT IMPACT

b) Would the project result in substantial soil erosion or the loss of topsoil?

Loose soils create conditions that can lead to erosion. The potential for erosion generally increases after soil has been disturbed by clearing and grading. As discussed in Section IV, *Air Quality*, dust control measures would be implemented during construction as required by the SCAQMD Rule 403 to minimize fugitive dust emissions. Measures to minimize fugitive dust emissions may include watering exposed surfaces and covering soil stockpiles. These measures are also effective for reducing soil erosion.

The California State Water Board adopted the most recent Construction General Permit (2009-0009-DWQ) on September 2, 2009. This permit became effective on July 1, 2010 and applies to construction sites greater than one acre in size. As required by the Construction General Permit, a SWPPP would be prepared for the proposed project. The SWPPP would specify BMPs to be implemented by the contractor during construction to minimize soil erosion, stormwater runoff and downstream impacts to water quality.

As described in Section IV, *Biological Resources*, the proposed project would be required to comply with the water quality requirements of the current MS4 permit, which requires that the amount of runoff from the site must be the same before and after construction of a project, and LID requirements, which require all infiltration water quality devices to be sized using the 0.75-inch storm or the 85th percentile storm, whichever is greater. Compliance with the MS4 permit and LID requirements would reduce on-site erosion from vegetated areas. As such, construction and operational impacts associated with sedimentation and erosion would be less than significant.

LESS THAN SIGNIFICANT IMPACT

c) Would the project be located on a geologic unit or soil that is unstable as a result of the project, and potentially result in on- or off-site landslide, lateral spreading, subsidence, liquefaction, or collapse?

Subsidence is the sudden sinking or gradual downward settling of the earth's surface with little or no horizontal movement. Subsidence is caused by a variety of activities, which include, but are not limited to, withdrawal of groundwater, pumping of oil and gas from underground, the collapse of underground mines, liquefaction, and hydrocompaction. Ground subsidence and



associated fissuring have occurred in different places in Los Angeles County, due to falling and rising groundwater tables. As discussed above, portions of the project site are also potentially susceptible to liquefaction and earthquake-induced landslides (2030 General Plan Seismic Hazard Zones Map, 2014). According to GeoSoils Consultants, Inc. and Willdan Engineering, the proposed project would be safe from the hazards of landslide, settlement, or slippage and would not adversely affect the stability of the adjacent properties nor be adversely affected by adjacent properties (Willdan Engineering and GeoSoils Consultants, Inc., 2015). Because the proposed project would be required to adhere to applicable CBC standards ensuring building safety, no significant subsidence-related impacts would result from the construction or operation of the proposed on-site uses. Therefore, impacts would be less than significant.

LESS THAN SIGNIFICANT IMPACT

d) Would the project be located on expansive soil, as defined in Table 1-B of the Uniform Building Code, creating substantial risks to life or property?

On-site soils consist of a Linne-Los Osos-Haploxerepts association, which are well drained and subject to expansion; thus, foundation and structural design would be required to incorporate measures prescribed in the CBC to address these design considerations and minimize related project impacts. Structural design measures would address depth, thickness and reinforcement requirements for concrete footings and the ground floor building slab. With implementation of standard design measures required in the CBC to address expansive soils, impacts would be less than significant.

LESS THAN SIGNIFICANT IMPACT

e) Would the project have soils incapable of adequately supporting the use of septic tanks or alternative wastewater disposal systems where sewers are not available for the disposal of wastewater?

The project would connect to the City's sewer system and would not require the use of septic tanks. Therefore, no impact would result and further analysis of this issue is not warranted.

NO IMPACT



	Potentially Significant Impact	Potentially Significant Unless Mitigation Incorporated	Less than Significant Impact	No Impact
--	--------------------------------	--	------------------------------	-----------

VII. GREENHOUSE GAS EMISSIONS

-- Would the project:

a) Generate greenhouse gas emissions, either directly or indirectly, that may have a significant impact on the environment?	<input type="checkbox"/>	<input type="checkbox"/>	<input checked="" type="checkbox"/>	<input type="checkbox"/>
b) Conflict with any applicable plan, policy, or regulation adopted for the purpose of reducing the emissions of greenhouse gases?	<input type="checkbox"/>	<input type="checkbox"/>	<input checked="" type="checkbox"/>	<input type="checkbox"/>

a) Would the project generate greenhouse gas emissions, either directly or indirectly, that may have a significant impact on the environment?

b) Would the project conflict with any applicable plan, policy, or regulation adopted for the purpose of reducing the emissions of greenhouse gases?

Climate change is the observed increase in the average temperature of the Earth’s atmosphere and oceans along with other substantial changes in climate (such as wind patterns, precipitation, and storms) over an extended period of time. Climate change is the result of numerous, cumulative sources of greenhouse gases (GHGs). GHGs contribute to the “greenhouse effect,” which is a natural occurrence that helps regulate the temperature of the planet. The majority of radiation from the Sun hits the Earth’s surface and warms it. The surface in turn radiates heat back towards the atmosphere, known as infrared radiation. Gases and clouds in the atmosphere trap and prevent some of this heat from escaping back into space and re-radiate it in all directions. This process is essential to supporting life on Earth because it warms the planet by approximately 60° Fahrenheit. Emissions from human activities since the beginning of the industrial revolution (approximately 250 years ago) may be adding to the natural greenhouse effect by increasing the gases in the atmosphere that trap heat, and as a result may be contributing to an average increase in the Earth’s temperature.

GHGs occur naturally and from human activities. Human activities that produce GHGs are the burning of fossil fuels (coal, oil and natural gas for heating and electricity, gasoline and diesel for transportation); methane from landfill wastes and raising livestock, deforestation activities; and some agricultural practices. GHGs produced by human activities include carbon dioxide (CO₂), methane (CH₄), nitrous oxide (N₂O), hydrofluorocarbons (HFCs), perfluorocarbons (PFCs), and sulfur hexafluoride (SF₆). Since 1750, it is estimated that the concentrations of carbon dioxide, methane, and nitrous oxide in the atmosphere have increased over by 36%, 148%, and 18% respectively, primarily due to human activity. Emissions of GHGs may affect the atmosphere directly by changing its chemical composition while changes to the land surface indirectly affect the atmosphere by changing the way in which the Earth absorbs gases from the atmosphere. Potential impacts of global climate change in California may include loss of snow



pack, sea level rise, more extreme heat days per year, more high ozone days, more large forest fires, and more drought years (CEC, March 2009).

California's major initiative for reducing GHG emissions is outlined in Assembly Bill 32 (AB 32), the "California Global Warming Solutions Act of 2006," signed into law in 2006. AB 32 codifies the statewide goal of reducing GHG emissions to 1990 levels by 2020 (essentially a 15% reduction below 2005 emission levels; the same requirement as under S-3-05), and requires ARB to prepare a Scoping Plan that outlines the main State strategies for reducing GHGs to meet the 2020 deadline. In addition, AB 32 requires ARB to adopt regulations to require reporting and verification of statewide GHG emissions.

Senate Bill (SB) 97, signed in August 2007, acknowledges that climate change is an environmental issue that requires analysis in California Environmental Quality Act (CEQA) documents. In March 2010, the California Resources Agency (Resources Agency) adopted amendments to the State CEQA Guidelines for the feasible mitigation of GHG emissions or the effects of GHG emissions. The adopted guidelines give lead agencies the discretion to set quantitative or qualitative thresholds for the assessment and mitigation of GHGs and climate change impacts.

Senate Bill (SB) 375, signed in August 2008, enhances the state's ability to reach AB 32 goals by directing ARB to develop regional GHG emission reduction targets to be achieved from vehicles for 2020 and 2035. In addition, SB 375 directs each of the state's 18 major Metropolitan Planning Organizations (MPO) to prepare a "sustainable communities strategy" (SCS) that contains a growth strategy to meet these emission targets for inclusion in the Regional Transportation Plan (RTP). On September 23, 2010, ARB adopted final regional targets for reducing GHG emissions from 2005 levels by 2020 and 2035.

The adopted *CEQA Guidelines* provide regulatory guidance on the analysis and mitigation of GHG emissions in CEQA documents, while giving lead agencies the discretion to set quantitative or qualitative thresholds for the assessment and mitigation of GHGs and climate change impacts. The 2008 SCAQMD threshold considers emissions of over 10,000 metric tons of carbon dioxide equivalent (CO₂E) per year from industrial development projects to be significant (SCAQMD, 2009). However, the SCAQMD's threshold applies only to stationary sources and is expressly intended to apply only when the SCAQMD is the CEQA lead agency. In the latest guidance provided by the SCAQMD's GHG CEQA Significance Threshold Working Group in September 2010, SCAQMD has considered a tiered approach to determine the significance of residential and commercial projects. The draft-tiered approach is outlined in the meeting minutes, dated September 29, 2010.

Tier 1 - If the project is exempt from further environmental analysis under existing statutory or categorical exemptions, there is a presumption of less than significant impacts with respect to climate change. If not, then the Tier 2 threshold should be considered.

Tier 2 - Consists of determining whether or not the project is consistent with a GHG reduction plan that may be part of a local general plan, for example. The concept embodied in this tier is equivalent to the existing concept of consistency in CEQA Guidelines section 15064(h)(3), 15125(d) or 15152(a). Under this Tier, if the proposed



project is consistent with the qualifying local GHG reduction plan, it is not significant for GHG emissions. If there is not an adopted plan, then a Tier 3 approach would be appropriate.

Tier 3 - Establishes a screening significance threshold level to determine significance. The Working Group has provided a recommendation of 3,000 tons of CO₂e per year for commercial projects.

The City of Calabasas has not adopted a Climate Action Plan. Because the City has not adopted any GHG emissions thresholds, the proposed project is evaluated based on the SCAQMD’s recommended Tier 3 screen level threshold of 3,000 metric tons CO₂e per year (SCAQMD, “Proposed Tier 3 Quantitative Thresholds – Option 1”, September 2010).

The GHG analysis has been conducted using the methodologies recommended by the California Air Pollution Control Officers Association [CAPCOA] (January 2008) *CEQA and Climate Change* white paper. The analysis focuses on CO₂, N₂O, and CH₄ as these are the GHG emissions that onsite development would generate in the largest quantities. Fluorinated gases, such as HFCs, PFCs, and SF₆, were also considered for the analysis. However, the quantity of fluorinated gases would not be significant since fluorinated gases are primarily associated with industrial processes. Calculations were based on the methodologies discussed in the CAPCOA white paper (January 2008) and included the use of the California Climate Action Registry General Reporting Protocol (January 2009).

Emissions associated with the proposed project were estimated using the California Emissions Estimator Model (CalEEMod) version 2013.2.2. Complete CalEEMod results and assumptions can be viewed in Appendix C.

Construction Emissions

Based on CalEEMod results, construction activity for the project would generate an estimated 740 metric tons of CO₂e (as shown in Table 8). Amortized over a 30-year period (the assumed life of the project), construction of the proposed project would generate about 25 metric tons of CO₂e per year.

Table 8
Estimated Construction
Emissions of Greenhouse Gases

	Emissions (metric tons CDE)
Total Emissions	740 metric tons
Amortized over 30 years	25 metric tons per year

See Appendix C for CalEEMod Results.

Operational Indirect and Stationary Direct Emissions

Operational emissions include area source, energy use, solid waste, water use, and transportation emissions. Table 9 combines the construction, operational and mobile GHG emissions associated with the proposed project. For the proposed project, the combined annual GHG emissions would total approximately 1,420 metric tons of CO₂e. The total amount of GHG emissions would be lower than the threshold of 3,000 metric tons of CO₂e per year. In addition,



the proposed hotel would be designed to achieve a LEED silver rating through use of water and energy efficient appliances, landscaping with native and drought-tolerant plants, construction waste management, building life-cycle impact reduction, and a pedestrian- and bicycle-friendly environment in order to further reduce GHG emissions.

**Table 9
 Combined Annual Emissions
 of Greenhouse Gases**

Emission Source	Annual Emissions CDE
Construction	25 metric tons
Operational <i>Area</i> <i>Energy</i> <i>Solid Waste</i> <i>Water</i>	<1 metric tons 291 metric tons 32 metric tons 17 metric tons
Mobile <i>CO₂ and CH₄</i> <i>N₂O</i>	1,003 metric tons 52 metric tons
Total Emissions from the Proposed Project	1,420 metric tons
<i>SCAQMD Proposed Tier 3 Threshold</i>	<i>3,000 metric tons</i>
Threshold exceeded?	No

Sources: See Appendix C for calculations and for GHG emission factor assumptions.

Senate Bill 375, signed in August 2008, requires the inclusion of sustainable communities' strategies in regional transportation plans for the purpose of reducing GHG emissions. In April 2012, SCAG adopted the 2012-2035 RTP/SCS. SCAG's RTP/SCS includes a commitment to reduce emissions from transportation sources by promoting compact and infill development and promoting alternative modes of transportation. A goal of the SCS is to "promote the development of better places to live and work through measures that encourage more compact development, varied housing options, bike and pedestrian improvements and efficient transportation infrastructure." The proposed hotel project would not conflict with any of these goals as it would allow for development of a commercially-designated site located along a major transportation corridor.

The proposed project would not conflict with any applicable plan, policy, or regulation adopted for the purpose of reducing emissions of GHGs and would be consistent with the objectives of the RTP/SCS, AB 32, SB 97, and SB 375.

LESS THAN SIGNIFICANT IMPACT



	Potentially Significant Impact	Potentially Significant Unless Mitigation Incorporated	Less than Significant Impact	No Impact
VIII. HAZARDS AND HAZARDOUS MATERIALS				
-- Would the project:				
a) Create a significant hazard to the public or the environment through the routine transport, use, or disposal of hazardous materials?	<input type="checkbox"/>	<input type="checkbox"/>	<input checked="" type="checkbox"/>	<input type="checkbox"/>
b) Create a significant hazard to the public or the environment through reasonably foreseeable upset and accident conditions involving the release of hazardous materials into the environment?	<input type="checkbox"/>	<input type="checkbox"/>	<input checked="" type="checkbox"/>	<input type="checkbox"/>
c) Emit hazardous emissions or handle hazardous or acutely hazardous materials, substances, or waste within ¼ mile of an existing or proposed school?	<input type="checkbox"/>	<input type="checkbox"/>	<input checked="" type="checkbox"/>	<input type="checkbox"/>
d) Be located on a site which is included on a list of hazardous material sites compiled pursuant to Government Code Section 65962.5 and, as a result, would it create a significant hazard to the public or the environment?	<input type="checkbox"/>	<input type="checkbox"/>	<input checked="" type="checkbox"/>	<input type="checkbox"/>
e) For a project located within an airport land use plan or, where such a plan has not been adopted, within two miles of a public airport or public use airport, would the project result in a safety hazard for people residing or working in the project area?	<input type="checkbox"/>	<input type="checkbox"/>	<input type="checkbox"/>	<input checked="" type="checkbox"/>
f) For a project within the vicinity of a private airstrip, would the project result in a safety hazard for people residing or working in the project area?	<input type="checkbox"/>	<input type="checkbox"/>	<input type="checkbox"/>	<input checked="" type="checkbox"/>
g) Impair implementation of or physically interfere with an adopted emergency response plan or emergency evacuation plan?	<input type="checkbox"/>	<input type="checkbox"/>	<input type="checkbox"/>	<input checked="" type="checkbox"/>
h) Expose people or structures to a significant risk of loss, injury, or death involving wildland fires, including where wildlands are adjacent to urbanized areas or where residences are intermixed with wildlands?	<input type="checkbox"/>	<input type="checkbox"/>	<input checked="" type="checkbox"/>	<input type="checkbox"/>



a) *Would the project create a significant hazard to the public or the environment through the routine transport, use, or disposal of hazardous materials?*

b) *Would the project create a significant hazard to the public or the environment through reasonably foreseeable upset and accident conditions involving the release of hazardous materials into the environment?*

The proposed hotel would not involve the routine transport, use or disposal of hazardous substances, other than minor amounts used for maintenance and landscaping. Minor amounts of potentially hazardous materials such as fuels, lubricants, and solvents could be used during construction of the project. However, the transport, use, and storage of hazardous materials during construction would be conducted in accordance with all applicable state and federal laws, such as the Hazardous Materials Transportation Act, Resource Conservation and Recovery Act, the California Hazardous Material Management Act, and the California Code of Regulations, Title 22. Adherence to these requirements would reduce impacts to a less than significant level.

LESS THAN SIGNIFICANT IMPACT

c) *Would the project emit hazardous emissions or handle hazardous or acutely hazardous materials, substances, or waste within ¼ mile of an existing or proposed school?*

The nearest existing schools are Lupin Hill Elementary School, located approximately one mile north of the project site, Muse private school located 0.5 miles south of the project site, and A.E. Wright Middle School, located approximately 0.9 miles south of the project site. The proposed hotel would not generate hazardous emissions and the project site is not located within ¼ mile of an existing or proposed school. Therefore, the project would not emit hazardous emissions or handle hazardous materials within one quarter mile of a school.

LESS THAN SIGNIFICANT IMPACT

d) *Would the project be located on a site which is included on a list of hazardous material sites compiled pursuant to Government Code Section 65962.5 and, as a result, would it create a significant hazard to the public or the environment?*

The following databases compiled pursuant to Government Code Section 65962.5 were checked (February 27, 2015) for known hazardous materials contamination at the project site:

- *Comprehensive Environmental Response, Compensation, and Liability Information System (CERCLIS) database*
- *Geotracker search for leaking underground storage tanks (LUSTs)*
- *Cortese list of Hazardous Waste and Substances Sites*
- *Department of Toxic Substances Control's Site Mitigation and Brownfields Database*

The project site does not appear on any of the above lists, but five LUST sites are within 1,000 feet of the project site. Two of the LUST sites are closed and one site is eligible for closure, indicating the sites are no longer hazards. The two remaining sites are both approximately 200 feet west of the project site and undergoing remediation for potential gasoline contamination.



Due to the distance between the LUSTs and the project site and their ongoing remediation, impacts related to hazardous material sites would be less than significant.

LESS THAN SIGNIFICANT IMPACT

e) For a project located within an airport land use plan or, where such a plan has not been adopted, within two miles of a public airport or public use airport, would the project result in a safety hazard for people residing or working in the project area?

f) For a project within the vicinity of a private airstrip, would the project result in a safety hazard for people residing or working in the project area?

There are no public or private airports on or adjacent to the project site. The nearest airport is Van Nuys Airport, located approximately 12 miles northeast of the project site. No impact related to airport hazards would occur.

NO IMPACT

g) Would the project impair implementation of or physically interfere with an adopted emergency response plan or emergency evacuation plan?

The project would conform to the site planning and project design standards contained in Calabasas Municipal Code Section 17.20.080, which requires that discretionary projects provide points of ingress and egress that include emergency access for police and fire vehicles as required by the Los Angeles County Consolidated Fire Districts (LACFD) and the city of Calabasas, and would ensure that emergency response access is maintained.

NO IMPACT

h) Would the project expose people or structures to a significant risk of loss, injury, or death involving wildland fires, including where wildlands are adjacent to urbanized areas or where residences are intermixed with wildlands?

The entire City of Calabasas, including the project site, is located within the Los Angeles County Consolidated Fire District's Very High Fire Hazard Severity Zone. This zone includes wildland fire hazard areas defined as watershed lands that contain native growth and vegetation (City Municipal Code, Section 17.20.130). The proposed project would adhere to standard requirements set forth by the City Municipal Code and the California Building Code (CBC) with City of Calabasas amendments, including driveway width requirements, the creation and maintenance of wildfire buffers, and sprinkler and alarm requirements. Impacts related to wildland fire would be less than significant with mandatory compliance with applicable building standards and regulations.

LESS THAN SIGNIFICANT IMPACT



	Potentially Significant Impact	Potentially Significant Unless Mitigation Incorporated	Less than Significant Impact	No Impact
IX. HYDROLOGY AND WATER QUALITY				
-- Would the project:				
a) Violate any water quality standards or waste discharge requirements?	<input type="checkbox"/>	<input type="checkbox"/>	<input checked="" type="checkbox"/>	<input type="checkbox"/>
b) Substantially deplete groundwater supplies or interfere substantially with groundwater recharge such that there would be a net deficit in aquifer volume or a lowering of the local groundwater table level (e.g., the production rate of pre-existing nearby wells would drop to a level which would not support existing land uses or planned uses for which permits have been granted)?	<input type="checkbox"/>	<input type="checkbox"/>	<input type="checkbox"/>	<input checked="" type="checkbox"/>
c) Substantially alter the existing drainage pattern of the site or area, including through the alteration of the course of a stream or river, in a manner which would result in substantial erosion or siltation on- or off-site?	<input type="checkbox"/>	<input type="checkbox"/>	<input checked="" type="checkbox"/>	<input type="checkbox"/>
d) Substantially alter the existing drainage pattern of the site or area, including the alteration of the course of a stream or river, or substantially increase the rate or amount of surface runoff in a manner which would result in flooding on- or off-site?	<input type="checkbox"/>	<input type="checkbox"/>	<input checked="" type="checkbox"/>	<input type="checkbox"/>
e) Create or contribute runoff water which would exceed the capacity of existing or planned stormwater drainage systems or provide substantial additional sources of polluted runoff?	<input type="checkbox"/>	<input type="checkbox"/>	<input checked="" type="checkbox"/>	<input type="checkbox"/>
f) Otherwise substantially degrade water quality?	<input type="checkbox"/>	<input type="checkbox"/>	<input checked="" type="checkbox"/>	<input type="checkbox"/>
g) Place housing within a 100-year flood hazard area as mapped on a federal Flood Hazard Boundary or Flood Insurance Rate Map or other flood hazard delineation map?	<input type="checkbox"/>	<input type="checkbox"/>	<input checked="" type="checkbox"/>	<input type="checkbox"/>
h) Place within a 100-year flood hazard area structures which would impede or redirect flood flows?	<input type="checkbox"/>	<input type="checkbox"/>	<input checked="" type="checkbox"/>	<input type="checkbox"/>



	Potentially Significant Impact	Potentially Significant Unless Mitigation Incorporated	Less than Significant Impact	No Impact
--	--------------------------------	--	------------------------------	-----------

IX. HYDROLOGY AND WATER QUALITY

-- Would the project:

- | | | | | |
|---|--------------------------|--------------------------|-------------------------------------|-------------------------------------|
| i) Expose people or structures to a significant risk of loss, injury, or death involving flooding, including flooding as a result of the failure of a levee or dam? | <input type="checkbox"/> | <input type="checkbox"/> | <input checked="" type="checkbox"/> | <input type="checkbox"/> |
| j) Result in inundation by seiche, tsunami, or mudflow? | <input type="checkbox"/> | <input type="checkbox"/> | <input type="checkbox"/> | <input checked="" type="checkbox"/> |

a) *Would the project violate any water quality standards or waste discharge requirements?*

e) *Would the project create or contribute runoff water which would exceed the capacity of existing or planned stormwater drainage systems or provide substantial additional sources of polluted runoff?*

f) *Would the project otherwise substantially degrade water quality?*

The project site is within the region covered by the Los Angeles County Municipal Storm Water NPDES Permit No. CAS004001 issued by the Los Angeles Regional Water Quality Control Board (LARWQCB). This permit governs non-point source discharges associated with storm water runoff. Regulations under the federal Clean Water Act require compliance with the NPDES storm water permit for projects disturbing more than one acre during construction. Per State regulations, the applicant would be required to file a Notice of Intent with the LARWQCB and prepare a SWPPP. The SWPPP would require the use of BMPs (such as gravel bags, silt fences, hay bales, check dams, hydro seed, mulch, and soil binders) during construction, which would prevent excessive storm water runoff pollution. The project developer would also be required to comply with the MS4 permit, which requires the integration of post-construction BMPs into the site’s overall drainage system and would further reduce the potential for pollutants to enter the storm drain system. In addition, the Los Angeles County Flood Control District (LACFCD) does not permit any increase in receiving water peak flows as a result of the project development. The project would be required to comply with the Los Angeles County Areawide MS4 permit, which requires that the amount of runoff from the site must be the same before and after construction of a project.

Spindler Engineering prepared a Hydrology Study for the proposed project in August 2014 (revised January 2015; see Appendix D). As shown in Figure 4, the proposed project would include a debris detention basin in the northern area of the project site that would be designed to detain 7 cubic feet per second (cfs) for a 50-year storm event, which would be the difference between pre- and post-project flows (see drainage details on Figure 7). In order to comply with the MS4 permit, the proposed project would include a rain water harvesting tank or ground water recharge tank that would capture first flush stormwater from impervious surfaces and reduce the amount of runoff and pollution that reaches the storm drain system. Because the



project would be required to include site drainage systems according to standards and provisions set forth by the City of Calabasas and County of Los Angeles, impacts related to water quality would be less than significant.

LESS THAN SIGNIFICANT IMPACT

c) Would the project substantially alter the existing drainage pattern of the site or area, including through the alteration of the course of a stream or river, in a manner which would result in substantial erosion or siltation on- or off-site?

d) Would the project substantially alter the existing drainage pattern of the site or area, including the alteration of the course of a stream or river, or substantially increase the rate or amount of surface runoff in a manner which would result in flooding on- or off-site?

The proposed project would not alter any watershed boundaries, impact a stream course or increase the quantity of water, erosion, or siltation in a stream or river. The project site currently drains through concrete drainages to storm drain inlets on Las Virgenes Road. The proposed project would include a drainage basin to capture the difference between pre- and post-project flows; therefore, the proposed project would not alter the drainage pattern on the site. Thus, while the project would add impervious surface to the site, it would not substantially affect runoff volumes or patterns on the site. In addition, as discussed above, LACFCD does not permit any increase in receiving water peak flows as a result of project development, and the project would be required to comply with this restriction. As such, the proposed project would not alter drainage patterns in a manner that would cause flooding, erosion, or siltation. Impacts would be less than significant.

LESS THAN SIGNIFICANT IMPACT

b) Would the project substantially deplete groundwater supplies or interfere substantially with groundwater recharge such that there would be a net deficit in aquifer volume or a lowering of the local groundwater table level (e.g., the production rate of pre-existing nearby wells would drop to a level which would not support existing land uses or planned uses for which permits have been granted)?

The Las Virgenes Municipal Water District would provide water to the project site and relies on imported water for its supplies. Therefore, the proposed project would not affect groundwater supplies or recharge. No impact would occur with respect to groundwater.

NO IMPACT

g) Would the project place housing within a 100-year flood hazard area as mapped on a federal Flood Hazard Boundary or Flood Insurance Rate Map or other flood hazard delineation map?

h) Would the project place within a 100-year flood hazard area structures which would impede or redirect flood flows?

i) Would the project expose people or structures to a significant risk of loss, injury, or death involving flooding, including flooding as a result of the failure of a levee or dam?



The project site is located in Flood Zone D, an area in which flood hazards are undetermined, but possible (FEMA Map No. 06037C1264F). The project site is not located within a known 100-year flood hazard zone (City of Calabasas 2030 General Plan, 2008). In addition, according to the 2030 General Plan FEIR (2008), the City of Calabasas is not in the dam inundation area for any major stream or river in the region. According to the Hydrology Study prepared for the proposed project, the project site includes two natural watershed tributaries that drain in a general westerly direction to an existing inlet near the northbound on-ramp to the 101 Freeway off Las Virgenes Road (see Appendix D). As described above, the proposed project would include an underground debris detention basin that would capture the difference between pre- and post-project stormwater flows and improve the existing network of concrete drainages (see Figure 4, Grading and Drainage Plan, and Figure 7, Drainage Details). Therefore, impacts with respect to flooding would be less than significant.

LESS THAN SIGNIFICANT IMPACT

j) Would the project result in inundation by seiche, tsunami, or mudflow?

The project site is not subject to risks related to seiche, tsunami or mudflows (2030 General Plan FEIR, 2008).

NO IMPACT

	Potentially Significant Impact	Potentially Significant Unless Mitigation Incorporated	Less than Significant Impact	No Impact
X. LAND USE AND PLANNING				
-- Would the project:				
a) Physically divide an established community?	<input type="checkbox"/>	<input type="checkbox"/>	<input type="checkbox"/>	<input checked="" type="checkbox"/>
b) Conflict with any applicable land use plan, policy, or regulation of an agency with jurisdiction over the project (including, but not limited to the general plan, specific plan, local coastal program, or zoning ordinance) adopted for the purpose of avoiding or mitigating an environmental effect?	<input type="checkbox"/>	<input type="checkbox"/>	<input type="checkbox"/>	<input checked="" type="checkbox"/>
c) Conflict with an applicable habitat conservation plan or natural community conservation plan?	<input type="checkbox"/>	<input type="checkbox"/>	<input type="checkbox"/>	<input checked="" type="checkbox"/>



a) *Would the project physically divide an established community?*

Development of the proposed project would not involve a road or other facility that would physically divide an established community. The project involves commercial development that is consistent with the 2030 General Plan land use designations for the site.

NO IMPACT

b) *Would the project conflict with any applicable land use plan, policy, or regulation of an agency with jurisdiction over the project (including, but not limited to the general plan, specific plan, local coastal program, or zoning ordinance) adopted for the purpose of avoiding or mitigating an environmental effect?*

The project site is currently designated Business-Retail (B-R) in the 2030 General Plan and zoned Commercial Retail (CR). The project site is located within the Las Virgenes Gateway Master Plan area. The B-R designation accommodates general shopping and commercial services with a basic land intensity or floor area ratio (FAR) of less than or equal to 0.2 and a maximum FAR of 0.4. Hotels are considered a commercial use and are permitted in the CR Zone with a CUP (City of Calabasas Municipal Code Section 17.11.010.f). In addition, the CR zone has a maximum allowable FAR of 0.40 for all buildings, a 78% maximum for site area coverage, and a 35-foot height limit, although additional height may be authorized by Development Plan (City of Calabasas Municipal Code Section 17.14.020). The proposed project would include a hotel that covers 10% of the net area of the project site with an FAR of 0.3575, while 48% of the net area of the project site would be undeveloped or landscaped. Because the proposed project would be four stories in height and would exceed 35 feet and include retaining walls exceeding 6 feet in height, it would require a Development Plan Permit (City of Calabasas Municipal Code Section 17.62.070). Assuming approval of a Development Plan Permit and CUP, no impact related to inconsistency with City plans and policies would occur.

NO IMPACT

c) *Would the project conflict with an applicable habitat conservation plan or natural community conservation plan?*

The proposed project would not conflict with any habitat conservation plan or natural community conservation plan as the project site is not subject to such plans.

NO IMPACT

	Potentially Significant Impact	Potentially Significant Unless Mitigation Incorporated	Less than Significant Impact	No Impact
--	---------------------------------------	---	-------------------------------------	------------------

XI. MINERAL RESOURCES

-- Would the project:

a) Result in the loss of availability of a known mineral resource that would be of value to the region and the residents of the state?

<input type="checkbox"/>	<input type="checkbox"/>	<input type="checkbox"/>	<input checked="" type="checkbox"/>
--------------------------	--------------------------	--------------------------	-------------------------------------



	Potentially Significant Impact	Potentially Significant Unless Mitigation Incorporated	Less than Significant Impact	No Impact
XI. MINERAL RESOURCES				
-- Would the project:				
b) Result in the loss of availability of a locally important mineral resource recovery site delineated on a local general plan, specific plan, or other land use plan?	<input type="checkbox"/>	<input type="checkbox"/>	<input type="checkbox"/>	<input checked="" type="checkbox"/>

a) Would the project result in the loss of availability of a known mineral resource that would be of value to the region and the residents of the state?

b) Would the project result in the loss of availability of a locally important mineral resource recovery site delineated on a local general plan, specific plan, or other land use plan?

The proposed project would not entail construction of structures or facilities for the purposes of extraction or exploration of mineral resources and the project would not result in the loss of availability of a mineral resource of local, regional, or statewide importance (2030 General Plan FEIR, 2008). No impact would occur with respect to mineral resources and further analysis of this issue is not warranted.

NO IMPACT

	Potentially Significant Impact	Potentially Significant Unless Mitigation Incorporated	Less than Significant Impact	No Impact
XII. NOISE				
-- Would the project result in:				
a) Exposure of persons to or generation of noise levels in excess of standards established in the local general plan or noise ordinance, or applicable standards of other agencies?	<input type="checkbox"/>	<input type="checkbox"/>	<input checked="" type="checkbox"/>	<input type="checkbox"/>
b) Exposure of persons to or generation of excessive groundborne vibration or groundborne noise levels?	<input type="checkbox"/>	<input type="checkbox"/>	<input checked="" type="checkbox"/>	<input type="checkbox"/>
c) A substantial permanent increase in ambient noise levels above levels existing without the project?	<input type="checkbox"/>	<input type="checkbox"/>	<input checked="" type="checkbox"/>	<input type="checkbox"/>
d) A substantial temporary or periodic increase in ambient noise levels in the project vicinity above levels existing	<input type="checkbox"/>	<input type="checkbox"/>	<input checked="" type="checkbox"/>	<input type="checkbox"/>



Potentially Significant Impact	Potentially Significant Unless Mitigation Incorporated	Less than Significant Impact	No Impact
--------------------------------------	--	------------------------------------	--------------

XII. NOISE

-- Would the project result in:
 without the project?

- | | | | | |
|---|--------------------------|--------------------------|--------------------------|-------------------------------------|
| e) For a project located within an airport land use plan or, where such a plan has not been adopted, within two miles of a public airport or public use airport, would the project expose people residing or working in the project area to excessive noise levels? | <input type="checkbox"/> | <input type="checkbox"/> | <input type="checkbox"/> | <input checked="" type="checkbox"/> |
| f) For a project within the vicinity of a private airstrip, would the project expose people residing or working in the project area to excessive noise? | <input type="checkbox"/> | <input type="checkbox"/> | <input type="checkbox"/> | <input checked="" type="checkbox"/> |

Noise level (or volume) is generally measured in decibels (dB) using the A-weighted sound pressure level (dBA). The A-weighting scale is an adjustment to the actual sound power levels to be consistent with that of human hearing response, which is most sensitive to frequencies around 4,000 Hertz (about the highest note on a piano) and less sensitive to low frequencies (below 100 Hertz).

Because of the logarithmic scale of the decibel unit, sound levels cannot be added or subtracted arithmetically. If a sound's physical intensity is doubled, the sound level increases by 3 dBA, regardless of the initial sound level. For example, 60 dBA plus 60 dBA equals 63 dBA. Where ambient noise levels are high in comparison to a new noise source, the change in noise level would be less than 3 dBA. For example, 70 dBA ambient noise levels are combined with a 60 dBA noise source the resulting noise level equals 70.4 dBA. Based on the logarithmic scale, a sound that is 10 dBA less than the ambient sound level has no effect on ambient noise. Because of the nature of the human ear, a sound must be about 10 dBA greater than the reference sound to be judged as twice as loud. In general, a 3 dBA change in community noise levels is noticeable, while 1-2 dBA changes generally are not perceived. Quiet suburban areas typically have noise levels in the range of 40-50 dBA, while arterial streets are in the 50-60+ dBA range. Normal conversational levels are in the 60-65 dBA range, and ambient noise levels greater than 65 dBA can interrupt conversations.

Noise that is experienced at any receptor can be attenuated by distance or the presence of noise barriers or intervening terrain. Sound from a single source (i.e., a point source) radiates uniformly outward as it travels away from the source in a spherical pattern. The sound level attenuates (or drops off) at a rate of 6 dBA for each doubling of distance. For acoustically absorptive, or soft, sites (i.e., sites with an absorptive ground surface, such as soft dirt, grass, or scattered bushes and trees), ground attenuation of about 1.5 dBA per doubling of distance normally occurs. A large object or barrier in the path between a noise source and a receiver can



substantially attenuate noise levels at the receiver. The amount of attenuation provided by this shielding depends on the size of the object, proximity to the noise source and receiver, surface weight, solidity, and the frequency content of the noise source. Natural terrain features (such as hills and dense woods) and human-made features (such as buildings and walls) can substantially reduce noise levels. Walls are often constructed between a source and a receiver specifically to reduce noise. A barrier that breaks the line of sight between a source and a receiver will typically result in at least 5 dBA of noise reduction.

On March 6, 2015, Rincon Consultants, Inc. performed three 15-minute weekday noise measurements at the project site using an ANSI Type II integrating sound level meter. The noise monitoring results are summarized in Table 10.

Table 10
Measured Noise Levels

#	Measurement Location	Approximate Distance from Centerline of Las Virgenes Road	Leq[15] (dBA) ¹
1	On Rondell Street, near on-ramp to northbound 101 Freeway	90 feet	69.2
2	On project site, near the approximate location of the hotel's westernmost rooms	160 feet	64.6
3	On project site, near the approximate location of the proposed pool	300 feet	59.5

Source: Rincon Consultants, Inc. Recorded during field visit using ANSI Type II Integrating sound level meter. See Appendix E for noise measurement results.

¹ *The equivalent noise level (Leq) is defined as the single steady A-weighted level that is equivalent to the same amount of energy as that contained in the actual fluctuating levels over a period of time (essentially, the average noise level). For this measurement the Leq was over a 15-minute period (Leq[15]).*

The equivalent noise level (Leq) measured at the project site over 15-minute periods (Leq[15]) ranged from 59.5 dBA near the approximate location of the pool to 69.2 on Rondell Street near the western boundary of the project site. The primary sources of roadway noise near the project site are automobiles traveling on Las Virgenes Road immediately west and the 101 Freeway north of the project site.

The City mapped CNEL noise exposure contours using the Federal Highway Traffic Noise Prediction Model for existing major noise sources, including freeways and primary arterial highways. Contour designations were formulated for conditions at the time the Noise Element was drafted. According to the contour map, the northern portion of the project site is located in the 70 dBA contour of the 101 Freeway, while the remainder of the project site falls within the existing 65 dBA contour of the freeway. The western portion of the project site is also located in the existing 70 dBA contour of Las Virgenes Road.

The City identifies the State Office of Noise Control land use compatibility guidelines as the standards for development within the City (2030 General Plan, 2008). Figure 12 shows the



ranges of noise exposure, for various land uses that are considered acceptable, conditionally acceptable, or unacceptable under the State Office of Noise Control guidelines and as adopted by the City of Calabasas General Plan Noise Element. An acceptable noise environment is one in which development may be permitted without requiring specific noise studies or specific noise-reducing features. A conditionally acceptable noise environment is one in which development should be permitted only after noise mitigation has been designed as part of the project, to reduce noise exposure to acceptable levels. In unacceptable noise environments, development generally should not be undertaken. For hotels, the normally acceptable range is up to 65 dBA, the conditionally acceptable range is from 60 to 70 dBA, and the normally unacceptable range is from 70 to 80 dBA. Noise levels measured on the project site range from conditionally acceptable on the portions of the site nearest to Rondell Street and the 101 Freeway and normally acceptable near the location of the hotel (see Table 10 above).

The City of Calabasas has adopted a noise ordinance (Ordinance No. 2010-265) that establishes ambient noise standards for all properties within various noise zones, using the hourly equivalent sound level, or Leq. This ordinance sets an exterior noise standard of 60-65 dBA between 7:00 A.M. and 10:00 P.M., depending on the residential zone, and 50 dBA between 10:00 P.M. and 7:00 A.M. for all residential zones (City of Calabasas Municipal Code, Section 17.20.160 D). Interior noise levels for all residential uses are 45 dBA between 7:00 A.M. and 10:00 P.M. and 40 dBA from 10:00 P.M. to 7:00 A.M. (City of Calabasas Municipal Code, Section 17.20.160 E). Commercial and special purpose zones have an exterior noise level standard of 65 dBA from 7:00 A.M. to 10:00 P.M. and 60 dBA from 10:00 P.M. to 7:00 A.M., with the exception that active recreational areas have a noise level standard of 70 dBA from 7:00 A.M. to 10:00 P.M. (City of Calabasas Municipal Code, Section 17.20.160 D).

The City's noise ordinance also exempts noise associated with construction activities between the hours of 7:00 A.M. and 6:00 P.M. during weekdays and 8:00 A.M. and 5:00 P.M. on Saturdays (City of Calabasas Municipal Code, Section 17.20.160 C).

Vibration is a unique form of noise because its energy is carried through buildings, structures, and the ground, whereas noise is simply carried through the air. Thus, vibration is generally felt rather than heard. The ground motion caused by vibration is measured as particle velocity in inches per second and is referenced as vibration decibels (VdB) in the U.S. The City has not adopted any thresholds or regulations addressing vibration.

The vibration velocity level threshold of perception for humans is approximately 65 VdB. A vibration velocity of 75 VdB is the approximate dividing line between barely perceptible and distinctly perceptible levels for many people (Federal Transit Administration, May 2006). The vibration thresholds established by the Federal Transit Administration (FTA) are 65 VdB for buildings where low ambient vibration is essential for interior operations (such as hospitals and recording studios), 72 VdB for residences and buildings where people normally sleep, including hotels, and 75 VdB for institutional land uses with primary daytime use (such as churches and schools). The threshold for the proposed project is 72 VdB for residences and hotels during hours when people normally sleep, as these are the only sensitive receptors in the vicinity of the project site. In terms of ground-borne vibration impacts on structures, the FTA states that ground-borne vibration levels in excess of 100 VdB would damage fragile buildings and levels in excess of 95 VdB would damage extremely fragile historic buildings.



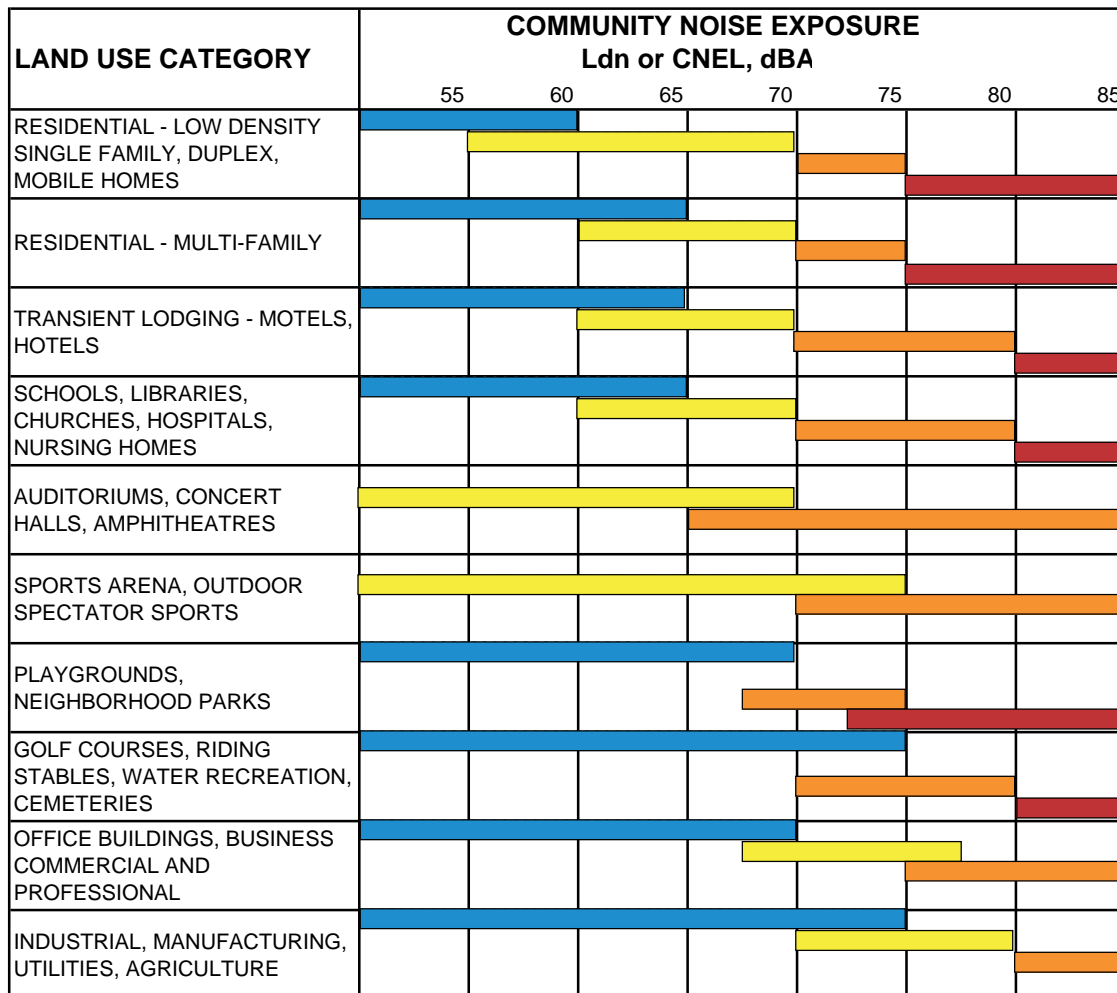

NORMALLY ACCEPTABLE
 Specified land use is satisfactory, based upon the assumption that any buildings involved are of normal conventional construction, without any special noise insulation requirements.

NORMALLY UNACCEPTABLE
 New construction or development should generally be discouraged. If new construction or development does proceed, a detailed analysis of the noise reduction requirements must be made and needed noise insulation features included in the design

CONDITIONALLY ACCEPTABLE
 New construction or development should be undertaken only after a detailed analysis of the noise reduction requirements is made and needed noise insulation features included in the design. Conventional construction, but with closed windows and fresh air supply systems or air conditioning will normally suffice.

CLEARLY UNACCEPTABLE
 New construction or development should generally not be undertaken.

Guidelines for the Preparation and Content of Noise Elements of the General Plan, California Office of Planning and Research, 2003.

Land Use Compatibility for Community Noise Environments

Figure 12

a) Would the project result in exposure of persons to or generation of noise levels in excess of standards established in the local general plan or noise ordinance, or applicable standards of other agencies?

c) Would the project result in a substantial permanent increase in ambient noise levels above levels existing without the project?

d) Would the project result in a substantial temporary or periodic increase in ambient noise levels in the project vicinity above levels existing without the project?

The entire project site is exposed to noise from the 101 Freeway, Las Virgenes Road, and the adjacent Mobil gas station and automatic car wash. According to the Noise Element of the City of Calabasas' General Plan (2008), the northern portion and the western edge of the project site is located in the 70 dBA noise contour of the 101 Freeway and Las Virgenes Road, while the remainder of the project site falls within the 65 dBA contour. Noise measurements taken onsite indicate that noise along the Las Virgenes Road frontage is approximately 69.2 dBA (see Table 10). Noise decreases to approximately 64.6 dBA near 160 feet from the centerline of Las Virgenes Road and 160 feet from the Mobil car wash and further decreases to 59.5 dBA near 300 feet from the Las Virgenes Road centerline and 160 feet from the carwash.

The proposed project's hotel use is within the 65 dBA noise contour for the 101 Freeway. A noise level exposure of 65 dBA would fall within the "normally acceptable" and "conditionally acceptable" ranges for hotel land uses. Moreover, as indicated in Table 10, two noise measurements taken at the location of the proposed hotel (location 2) and pool (location 3) were approximately 64.6 dBA and 59.5 dBA, which is lower than the Freeway 101 noise contour for this location. Additionally, the exterior noise in the proposed courtyard and pool area of the project would not exceed the exterior noise level standard of 65 dBA from 7:00 AM. to 10:00 PM and 60 dBA from 10:00 PM. to 7:00 AM because the proposed hotel building would shield the area and further attenuate roadway noise from the 101 Freeway and Las Virgenes Road (City of Calabasas Municipal Code, Section 17.20.160 D). Therefore, noise generated along the 101 Freeway and Las Virgenes Road would not significantly affect the hotel use on the project site.

Construction Noise

Noise levels from construction of the proposed project would result from construction of the structure and traffic noise from construction vehicles. Nearby noise-sensitive land uses, such as residences 800 feet south of the project site, would be exposed to temporary construction noise during development of the proposed project. Noise impacts are a function of the type of activity being undertaken and the distance to the receptor location. Construction activity is expected to occur over a period of approximately 13 months. Table 11 shows the typical noise levels at construction sites.



Table 11
Typical Noise Levels at Construction Sites

Equipment Onsite	Typical Level (dBA) 25 Feet from the Source	Typical Level (dBA) 100 Feet from the Source	Typical Level (dBA) 800 Feet from the Source
Air Compressor	87	75	57
Backhoe	86	74	56
Concrete Mixer	91	79	61
Crane, mobile	89	77	59
Dozer	91	79	61
Jack Hammer	94	82	64
Paver	95	83	65
Saw	82	70	52
Truck	94	82	64

*Noise levels assume a noise attenuation rate of 6dBA per doubling of distance.
 Source: Federal Transit Administration (FTA), May 2006*

Typical noise levels from individual pieces of construction equipment range from about 52 to 65 dBA at a distance of 800 feet. Such levels, which would occur intermittently during the 13-month construction period, would be similar to ambient sound levels in the area of the residences. However, as discussed above, pursuant to City of Calabasas Municipal Code Section 17.20.160 C, noise associated with construction activities is only allowed between the hours of 7:00 AM and 6:00 PM during weekdays and 8:00 AM and 5:00 PM on Saturdays. Therefore, construction would not occur during recognized sleep hours for residences.

Operational Noise

Operation of the proposed hotel would generate noise typically associated with commercial uses, such as rooftop ventilation and heating systems, delivery trucks, trash hauling, parking lot noise, and on-site circulation of motor vehicles. Noise levels generated by commercial development would not disturb the residents located approximately 800 feet south of the project site. The distance from the proposed hotel to off-site sensitive receptors and the presence of intervening structures and roadways would attenuate operational noise associated with commercial uses. Typical noise sources associated with parking lots include tire squeal, doors slamming, car alarms, horns, and engine start-ups. Noise from typical parking lot activities such as car alarms can reach up to 66 dBA at 50 feet; door slams up to 72 dBA at 50 feet; vehicle tire squeals up to 72 dBA at 50 feet; and vehicle start-ups up to 73 dBA at 50 feet. Noise levels within the parking area would fluctuate with the amount of automobile and human activity. More generally, noise levels would be highest during the day, when the largest number of employees and visitors would enter and exit the parking lot. The maximum source of noise from the parking area, vehicle start-ups, would be 73 dBA at 50 feet, attenuating over 800 feet to approximately 49 dBA at the nearest residences. Therefore, operational noise generated from commercial uses would not expose off-site sensitive receptors to noise levels above the exterior noise level standards.



As discussed under Section IV, *Biological Resources*, the project site is located within the western portion the City of Calabasas mapped Wildlife Linkage and Corridor, as defined in the City of Calabasas 2030 General Plan Conservation Element. The proposed project may expose the wildlife corridor to operational noise from the hotel. Walls along the eastern and southern boundaries of the project's developed area (see Figure 3, Site Plan) would reduce noise levels on adjacent natural areas from operation of the hotel and parking lot. Additionally, implementation of Mitigation Measure BIO-2 would require sound amplification equipment to be shielded and would reduce impacts to biological resources to a less than significant level.

According to the project traffic analysis (Appendix F), the proposed project would generate an estimated 1,038 new average daily trips (ADT), 67 new AM peak hour, and 76 new PM peak hour trips along study area roadway segments. Project-generated traffic would incrementally increase noise levels along these roadway segments. The increase in noise along these roadway segments was calculated using the maximum of A.M. and P.M. peak hour trips from the traffic analysis and noise generation rates from the TNM lookup tables (see Appendix E).

Table 12 compares pre- and post-project noise levels along project area roadway segments. As shown in Table 12, the greatest increase in project-generated traffic noise would be a 0.1 dBA increase along the Las Virgenes Road north of Agoura Road segment and the Agoura Road west of Las Virgenes Road segment. The greatest increase in cumulative plus project-generated traffic noise would be a 0.4 dBA increase at the Agoura Road west of Las Virgenes Road segment. As discussed above, a 3 dBA change in community noise levels is noticeable, while 1 to 2 dBA changes generally are not perceived. Therefore, an increase of 0.1 or 0.4 dBA would not result in an audible change in ambient noise at sensitive receptor locations along area roadways. Furthermore, an increase of 0.1 or 0.4 dBA would not exceed the 1 dBA threshold established by the FTA for roadways with an existing noise exposure of 65-70 dBA. As such, the proposed project would not result in a substantial permanent increase in ambient noise levels in the project site vicinity and impacts would be less than significant.



Table 12
Comparison of Pre-Project and Post-Project Traffic Noise
On Project Area Roadways

Roadway	Projected Noise Level ^a (dBA CNEL)			Change In Noise Level (dBA)		Significant?
	Existing (1)	Existing + Project (2)	Cumulative + Project (3)	Due to Project Traffic (2-1)	Due to Cumulative Traffic Growth (3-1)	
Las Virgenes Road north of Agoura Road	68.8	68.9	69.1	0.1	0.3	No
Las Virgenes Road south of Agoura Road	68.2	68.2	68.5	<0.1	0.3	No
Agoura Road west of Las Virgenes Road	67.7	67.8	68.1	0.1	0.4	No

Notes: TNM Look-Up Tables, see Appendix E.

^a Estimate of noise generated by traffic approximately 50 feet from the centerline of the roadway. Refer to Appendix E for TNM data sheets. Noise levels presented do not account for attenuation provided by existing topography, barriers or future barriers; therefore, actual noise levels at sensitive receptor locations influenced by study area roadways may in many cases be lower than presented herein.

LESS THAN SIGNIFICANT IMPACT

b) Would the project result in exposure of persons to or generation of excessive groundborne vibration or groundborne noise levels?

Operation of the proposed hotel would not perceptibly increase groundborne vibration or groundborne noise on the project site above existing conditions. Construction of the proposed project could potentially increase groundborne vibration on the project site, but construction effects would be temporary. The nearest sensitive receptors are residences at the Shea Colony approximately 800 feet south of the project site. Based on the information presented in Table 13, during construction, these residences would be exposed to maximum vibration levels of approximately 55 VdB because vibration, like noise, attenuates over distance.

Table 13
Vibration Source Levels for Construction Equipment

Equipment	Approximate VdB					
	25 Feet	50 Feet	60 Feet	75 Feet	100 Feet	800 Feet
Loaded Trucks	86	80	78	76	74	55
Jackhammer	79	73	71	69	67	48
Small Bulldozer	58	52	50	48	46	27

Source: Federal Railroad Administration, 1998

As discussed above, 100 VdB is the general threshold where minor damage can occur in fragile buildings. Because vibration levels would not reach 100 VdB, structural damage would not be



expected to occur as a result of construction activities. The vibration levels at residences to the south would not exceed the groundborne velocity threshold level of 72 VdB established by the Federal Transit Administration for residences and buildings where people normally sleep. In addition, as discussed above, the City of Calabasas only exempts noise associated with construction activities between the hours of 7:00 AM and 6:00 PM during weekdays and 8:00 AM and 5:00 PM on Saturdays from its Noise Ordinance restrictions (City of Calabasas Municipal Code, Section 17.20.160 C). Construction would not occur during recognized sleep hours for residences. As such, vibration effects from proposed project construction would be less than significant.

LESS THAN SIGNIFICANT IMPACT

e) For a project located within an airport land use plan or, where such a plan has not been adopted, within two miles of a public airport or public use airport, would the project expose people residing or working in the project area to excessive noise levels?

f) For a project within the vicinity of a private airstrip, would the project expose people residing or working in the project area to excessive noise?

The airport nearest to the project site is Van Nuys Airport, located approximately 12 miles northeast of the site. The project would not be subject to excessive noise levels associated with airport operations.

NO IMPACT

	Potentially Significant Impact	Potentially Significant Unless Mitigation Incorporated	Less than Significant Impact	No Impact
--	--------------------------------	--	------------------------------	-----------

XIII. POPULATION AND HOUSING

-- Would the project:

a) Induce substantial population growth in an area, either directly (for example, by proposing new homes and businesses) or indirectly (for example, through extension of roads or other infrastructure)?	<input type="checkbox"/>	<input type="checkbox"/>	<input checked="" type="checkbox"/>	<input type="checkbox"/>
b) Displace substantial numbers of existing housing, necessitating the construction of replacement housing elsewhere?	<input type="checkbox"/>	<input type="checkbox"/>	<input type="checkbox"/>	<input checked="" type="checkbox"/>
c) Displace substantial numbers of people, necessitating the construction of replacement housing elsewhere?	<input type="checkbox"/>	<input type="checkbox"/>	<input type="checkbox"/>	<input checked="" type="checkbox"/>

a) Would the project induce substantial population growth in an area, either directly (for example, by proposing new homes and businesses) or indirectly (for example, through extension of roads or other infrastructure)?



SCAG produces forecasts of regional population, which form the basis for growth projection in SCAG's 2012 RTP-SCS. SCAG's growth forecast projects a population of 24,400 for Calabasas in 2035, an increase of 457 from the estimated 2013 population of 23,943 (California Department of Finance, 2014). As discussed in Section 4.10 of the 2030 General Plan FEIR (2008), given that Calabasas is primarily built out and the General Plan includes numerous policies and objectives aimed at limiting further growth, no exceedance of SCAG population forecasts for the City is anticipated.

The proposed project would involve development of the project site in general accordance with the uses prescribed in the 2030 General Plan. The development of a four-story hotel with up to 127-rooms and a gross floor area of approximately 72,954 sf could cause an indirect increase in the City's population. SCAG's Employee Density Study (2001) states that, in Los Angeles County, hotels generate approximately one employee per 1,179 sf. Based on this factor, the project would generate an estimated 62 employees. The current City population is approximately 23,943, according to the most recent (2014) California Department of Finance estimate. Therefore, although most employees are expected to be drawn from the local workforce, the proposed project could result in a citywide population of approximately 24,005 persons if all the employees moved into the City from elsewhere. Therefore, development of the proposed project would not add population beyond that anticipated in the 2030 General Plan projection, which is consistent with SCAG's 2030 growth forecast (2030 General Plan FEIR, 2008). Impacts related to population growth would be less than significant.

LESS THAN SIGNIFICANT IMPACT

b) Would the project displace substantial numbers of existing housing, necessitating the construction of replacement housing elsewhere?

c) Would the project displace substantial numbers of people, necessitating the construction of replacement housing elsewhere?

The proposed project would not involve the demolition of any residential units. Thus, the project would not displace housing units or people, or necessitate the construction of replacement housing. No impact related to the displacement of people and housing would occur.

NO IMPACT



	Potentially Significant Impact	Potentially Significant Unless Mitigation Incorporated	Less than Significant Impact	No Impact
--	--------------------------------------	--	------------------------------------	--------------

XIV. PUBLIC SERVICES

a) Would the project result in substantial adverse physical impacts associated with the provision of new or physically altered governmental facilities, or the need for new or physically altered governmental facilities, the construction of which could cause significant environmental impacts, in order to maintain acceptable service ratios, response times or other performance objectives for any of the public services:

i) Fire protection?	<input type="checkbox"/>	<input type="checkbox"/>	<input checked="" type="checkbox"/>	<input type="checkbox"/>
ii) Police protection?	<input type="checkbox"/>	<input type="checkbox"/>	<input checked="" type="checkbox"/>	<input type="checkbox"/>
iii) Schools?	<input type="checkbox"/>	<input type="checkbox"/>	<input checked="" type="checkbox"/>	<input type="checkbox"/>
iv) Parks?	<input type="checkbox"/>	<input type="checkbox"/>	<input checked="" type="checkbox"/>	<input type="checkbox"/>
v) Other public facilities?	<input type="checkbox"/>	<input type="checkbox"/>	<input checked="" type="checkbox"/>	<input type="checkbox"/>

a (i) Would the project result in substantial adverse physical impacts associated with the provision of new or physically altered governmental facilities, or the need for new or physically altered governmental facilities, the construction of which could cause significant environmental impacts, in order to maintain acceptable service ratios, response times or other performance objectives for fire protection?

The LACFD provides fire protection services to the project site. The nearest fire station is Station #125, located at 5215 Las Virgenes Road, in Calabasas. The site is approximately one half mile (driving distance) from the fire station, with access via Las Virgenes Road.

The proposed project would incrementally increase demand for fire protection service. However, the proposed project would be required to pay standard development impact mitigation fees (L. Bagwell, pers. comm., March 2015). In addition, the applicant would be required to comply with the Fire Code and LACFD standards, including specific construction specifications, access design, location of fire hydrants, and other design requirements. Because the project site is within the current service area for Station #125, it would not require the construction of new or expanded fire protection facilities. Impacts related to fire services would be less than significant.

LESS THAN SIGNIFICANT IMPACT



a (ii) Would the project result in substantial adverse physical impacts associated with the provision of new or physically altered governmental facilities, or the need for new or physically altered governmental facilities, the construction of which could cause significant environmental impacts, in order to maintain acceptable service ratios, response times or other performance objectives for police protection?

The Los Angeles County Sheriff's Department (LASD) provides police protection service in Calabasas and to the project site. The nearest LASD station is the Malibu/Lost Hills Sheriff's Station located at 27050 Agoura Road in the City of Agoura, approximately 1.5 miles west of the project site. The Station's service area is approximately 178 square miles, which includes the cities of Agoura Hills, Calabasas, Hidden Hills, Malibu, and Westlake Village, as well as the surrounding communities of Chatsworth Lake Manor, Malibu Lake, Topanga, and West Hills (P. Davoren, pers. comm., June 11, 2015). The estimated resident population of the service area is 90,000. The Station is staffed by 107 sworn deputies and 78 civilian employees and staffing is expected to remain unchanged for the foreseeable future (P. Davoren, pers. comm., June 11, 2015). There are currently 40 patrol vehicles, 6 motorcycles, and 60 other law enforcement vehicles assigned to the Station. The Station is also supported by other Department assets, including helicopters, fixed-wing aircraft, emergency operations equipment, search and rescue equipment, and mounted patrol.

The Station's current service ratio is one deputy per 833 residents (P. Davoren, pers. comm., June 11, 2015). On average, the Station's response times throughout its service area is zero to ten minutes for emergent calls for service, zero to 20 minutes for priority calls for service, and zero to 60 minutes for routine calls for service. The LASD has stated concerns about potential long-term needs for additional staff and assets to meet future demands for service, but states that due to the relative proximity of the project site to the Station, the Station's response times to calls for service from the proposed project would fall within the times ranges described above. The proposed project would incrementally increase demand for police protection service. However, the site is within the current LASD service area and the LASD indicates that the proposed project would not adversely affect the Station's resources and operations (P. Davoren, pers. comm., June 11, 2015).

LESS THAN SIGNIFICANT IMPACT

a (iii) Would the project result in substantial adverse physical impacts associated with the provision of new or physically altered governmental facilities, or the need for new or physically altered governmental facilities, the construction of which could cause significant environmental impacts, in order to maintain acceptable service ratios, response times or other performance objectives for schools?

The project would not directly cause an increase in school age population since it involves the construction of a hotel. Thus, the proposed project would not require new or expanded schools to maintain acceptable service ratios or other performance objectives.

As of January 1987, State law allows school districts to levy three different levels of development fees directly on new residential, commercial, and industrial development (Government Code Section 65995). Districts set their own fees within this limit based on a nexus study establishing their funding requirements. Since Proposition 1A was passed by the voters and Government Code Section 65995(h) was adopted by the State Legislature in 1996, school fees generated by new development are deemed legally-sufficient mitigation of any impacts



based on generation of students on school facilities. The project site is located within the Las Virgenes Unified School District (LVUSD) and would be served by Calabasas High School, A. E. Wright Middle School, and Lupin Hill Elementary School.

LESS THAN SIGNIFICANT IMPACT

a (iv) Would the project result in substantial adverse physical impacts associated with the provision of new or physically altered governmental facilities, or the need for new or physically altered governmental facilities, the construction of which could cause significant environmental impacts, in order to maintain acceptable service ratios, response times or other performance objectives for parks?

The City of Calabasas maintains a parkland target ratio of 3 acres per 1,000 residents (City of Calabasas General Plan, 2008). As described in Section XIII, *Population and Housing*, the proposed project would not directly increase the population because it does not include residential uses, but may indirectly increase the population by 62 residents if all new employees relocated to the City. Employees may use existing park facilities; however increased demand would be nominal. The proposed project includes on-site amenities for hotel guests, including a pool, exercise room, and a trail connecting to the abutting Calabasas Historic Trail, also known as the Juan Bautista de Anza Historic Trail. The proposed project would relocate the existing trailhead access, create dedicated parking for the trail, and improve the trailhead with trash, recycle, and dog waste receptacles and signage. Impacts related to parks would be less than significant.

LESS THAN SIGNIFICANT IMPACT

a (v) Would the project result in substantial adverse physical impacts associated with the provision of new or physically altered governmental facilities, or the need for new or physically altered governmental facilities, the construction of which could cause significant environmental impacts, in order to maintain acceptable service ratios, response times or other performance objectives for other public facilities?

Library services are provided by the Calabasas Library located at 200 Civic Center Way in Calabasas. The Calabasas Library was built in 2008 and serves 41,780 registered users (Calabasas Library, 2013). As of 2013, the Library employed 23 full and part time staff members and had over 60,000 print materials available, as well as electronic books, downloadable audio books, magazines, and online databases (Calabasas Library, 2013). As described in Section XIII, *Population and Housing*, the proposed project would not directly increase the population because it does not include residential uses, but may indirectly increase the population by 62 residents if all new employees relocated to the City. Employees may use existing library facilities; however, even with such an increase in residential population demand for library services would increase by only 0.1% (the percentage increase of adding 62 new registered users to the 41,780 existing library users). Additional library facilities would not be needed.

LESS THAN SIGNIFICANT IMPACT



	Potentially Significant Impact	Potentially Significant Unless Mitigation Incorporated	Less than Significant Impact	No Impact
--	--------------------------------------	--	------------------------------------	--------------

XV. RECREATION

- | | | | | |
|--|--------------------------|--------------------------|-------------------------------------|--------------------------|
| a) Would the project increase the use of existing neighborhood and regional parks or other recreational facilities such that substantial physical deterioration of the facility would occur or be accelerated? | <input type="checkbox"/> | <input type="checkbox"/> | <input checked="" type="checkbox"/> | <input type="checkbox"/> |
| b) Does the project include recreational facilities or require the construction or expansion of recreational facilities which might have an adverse physical effect on the environment? | <input type="checkbox"/> | <input type="checkbox"/> | <input checked="" type="checkbox"/> | <input type="checkbox"/> |

a) Would the project increase the use of existing neighborhood and regional parks or other recreational facilities such that substantial physical deterioration of the facility would occur or be accelerated?

b) Does the project include recreational facilities or require the construction or expansion of recreational facilities which might have an adverse physical effect on the environment?

Please see the discussion above under Section XIV.a.iv, *Public Services*. Impacts related to recreation would be less than significant.

LESS THAN SIGNIFICANT IMPACT

	Potentially Significant Impact	Potentially Significant Unless Mitigation Incorporated	Less than Significant Impact	No Impact
--	--------------------------------------	--	------------------------------------	--------------

XVI. TRANSPORTATION/TRAFFIC

-- Would the project:

- | | | | | |
|--|--------------------------|--------------------------|-------------------------------------|--------------------------|
| a) Conflict with an applicable plan, ordinance or policy establishing a measure of effectiveness for the performance of the circulation system, taking into account all modes of transportation, including mass transit and non-motorized travel and relevant components of the circulation system, including but not limited to intersections, streets, highways, and freeways, pedestrian and bicycle paths, and mass transit? | <input type="checkbox"/> | <input type="checkbox"/> | <input checked="" type="checkbox"/> | <input type="checkbox"/> |
|--|--------------------------|--------------------------|-------------------------------------|--------------------------|



	Potentially Significant Impact	Potentially Significant Unless Mitigation Incorporated	Less than Significant Impact	No Impact
XVI. TRANSPORTATION/TRAFFIC				
-- Would the project:				
b) Conflict with an applicable congestion management program, including, but not limited to level of service standards and travel demand measures, or other standards established by the county congestion management agency for designated roads or highways?	<input type="checkbox"/>	<input type="checkbox"/>	<input checked="" type="checkbox"/>	<input type="checkbox"/>
c) Result in a change in air traffic patterns, including either an increase in traffic levels or a change in location that results in substantial safety risks?	<input type="checkbox"/>	<input type="checkbox"/>	<input type="checkbox"/>	<input checked="" type="checkbox"/>
d) Substantially increase hazards due to a design feature (e.g., sharp curves or dangerous intersections) or incompatible use (e.g., farm equipment)?	<input type="checkbox"/>	<input type="checkbox"/>	<input checked="" type="checkbox"/>	<input type="checkbox"/>
e) Result in inadequate emergency access?	<input type="checkbox"/>	<input type="checkbox"/>	<input checked="" type="checkbox"/>	<input type="checkbox"/>
f) Conflict with adopted policies, plans, or programs regarding public transit, bikeways, or pedestrian facilities, or otherwise substantially decrease the performance or safety of such facilities?	<input type="checkbox"/>	<input type="checkbox"/>	<input checked="" type="checkbox"/>	<input type="checkbox"/>

a) Would the project conflict with an applicable plan, ordinance or policy establishing a measure of effectiveness for the performance of the circulation system, taking into account all modes of transportation, including mass transit and non-motorized travel and relevant components of the circulation system, including but not limited to intersections, streets, highways, and freeways, pedestrian and bicycle paths, and mass transit?

Overland Traffic Consultants, Inc. prepared a traffic impact analysis for the proposed project (December 2014; see Appendix F). Trip generation estimates were developed utilizing trip generation rates and equations from *Trip Generation, 9th Edition* (Institute of Transportation Engineers, 2012). As shown in Table 14, the proposed project would generate approximately 1,038 daily vehicle trips, including 67 AM and 76 PM peak hour trips.



Table 14
Estimated Project Traffic Trip Generation

Land Use	Quantity	Weekday Peak Hour		Total Daily Trips
		AM	PM	
Hotel	127 rooms	67	76	1,038

Source: Overland Traffic Consultants, Inc., 2014; See Appendix F for full traffic analysis.

Level of Service (LOS) calculations were performed at the following intersections:

- *Las Virgenes Road and Mureau Road*
- *Las Virgenes Road and Southbound 101 Freeway Ramps*
- *Las Virgenes Road and Northbound 101 Freeway Ramps/Rondell Street*
- *Las Virgenes Road and Agoura Road*
- *Lost Hills Road and Agoura Road*

The following City of Calabasas Traffic Impact Analysis scenarios were evaluated:

- *Existing (2014) traffic conditions*
- *Existing + project traffic conditions*
- *Future (2016) + cumulative impacts*
- *Future (2016) + project traffic conditions*

The significance of the potential impacts of project-generated traffic was identified using the traffic impact criteria set forth in the City of Calabasas’ 2030 General Plan (December 2008) for City intersections. The minimum acceptable LOS at an intersection in the City is LOS C except at freeway interchanges and the two lane segment of Calabasas Road that traverses Old Town Calabasas. The performance level for freeway interchange locations is LOS D and the Old Town Calabasas section of Calabasas Road is LOS F.

The City of Calabasas has developed policies to address potential traffic impacts created by new development. Policy VI-2 states a need to limit the intensity and traffic generation of new development in the City to that which would compromise attainment of the maintenance of roadway level of service standards indicated above. Police VI-3 states that where existing or projected traffic volumes at General Plan buildout prevent a project from complying with VI-2, the development should be limited in intensity during the peak hours to not exceed the criteria shown in Table 15. Exceeding these limits is defined as a significant traffic impact and mitigation would be required to reduce the level of impact below these thresholds.



Table 15
Criteria for Significant Traffic Impact

Existing or Future Intersection LOS	Final ICU Value	Project-related increase in ICU value
D	0.81 – 0.90	+0.020
E	0.91 – 1.00	+0.015
F	> 1.0	+0.010 or more

Source: Overland Traffic Consultants, Inc., 2014; See Appendix F for full traffic analysis.

The existing (2014) LOS conditions for the five study area intersections are shown in Table 16.

Table 16
Level of Service for Existing (2014) Conditions

No.	Intersection	Peak Hour	Existing	
			ICU/Delay	LOS
1	Las Virgenes Road and Mureau Road ^a	AM	0.506	A
		PM	0.641	B
2	Las Virgenes Road and Northbound 101 Freeway Ramps/Rondell Street ^b	AM	24.0	C
		PM	18.7	B
3	Las Virgenes Road and Southbound 101 Freeway Ramps ^b	AM	11.5	B
		PM	21.1	C
4	Las Virgenes Road and Agoura Road ^a	AM	0.610	B
		PM	0.599	A
5	Lost Hills Road and Agoura Road ^a	AM	0.501	A
		PM	0.601	B

Source: Overland Traffic Consultants, Inc., 2014; See Appendix F for full traffic analysis.

^a Intersections analyzed using ICU volume/capacity ratios

^b Intersections analyzed using HCM Delay seconds per vehicle

The study area intersections are projected to operate within acceptable LOS during the peak hours for existing + project traffic conditions as shown on Table 17.



Table 17
Traffic Conditions for Existing + Project

No.	Intersection	Peak Hour	Existing		Existing + Project			Significant Impact?
			ICU/Delay	LOS	ICU/Delay	LOS	Change	
1	Las Virgenes Road and Mureau Road ^a	AM	0.506	A	0.509	A	+0.003	No
		PM	0.641	B	0.646	B	+0.005	No
2	Las Virgenes Road and Northbound 101 Freeway Ramps/Rondell Street ^b	AM	24.0	C	24.8	C	+0.8	No
		PM	18.7	B	18.8	B	+0.1	No
3	Las Virgenes Road and Southbound 101 Freeway Ramps ^b	AM	11.5	B	11.6	C	+0.1	No
		PM	21.1	C	22.4	C	+1.3	No
4	Las Virgenes Road and Agoura Road ^a	AM	0.610	B	0.613	B	+0.003	No
		PM	0.599	A	0.603	B	+0.004	No
5	Lost Hills Road and Agoura Road ^a	AM	0.501	A	0.504	A	+0.003	No
		PM	0.601	B	0.602	B	+0.001	No

Source: Overland Traffic Consultants, Inc., 2014; See Appendix F for full traffic analysis.

^a Intersections analyzed using ICU volume/capacity ratios

^b Intersections analyzed using HCM Delay seconds per vehicle

Future traffic volume projections were developed to analyze the traffic conditions after completion of other planned land developments including the proposed project. Ambient growth represents projects being developed outside of the analysis area or projects not currently identified which may add traffic to the area intersections. The ambient growth rate used for the project was based on the SCAG Profile of the City of Calabasas dated May 2013. Growth between years 2000 and 2012 was 10.9% which equates to an average of 0.91% per year (10.9%/12 years = 0.91%/year). This was rounded to 1% per year.

The future cumulative analysis includes other development projects located within the study area that are either under construction or planned. As part of this analysis, the related project information was obtained from the City of Calabasas and Los Angeles County and is detailed in the traffic analysis in Appendix F. Future analysis includes worst case assumptions of traffic generation (all projects being constructed) and does not incorporate intersection improvements proposed and required by any of the other cumulative projects. The future cumulative traffic conditions without the proposed project at study area intersections are shown in Table 18.



**Table 18
 Future Cumulative Traffic Conditions without Project**

No.	Intersection	Peak Hour	Existing		Future (2016) without Project		
			ICU/Delay	LOS	ICU/Delay	LOS	Growth
1	Las Virgenes Road and Mureau Road ^a	AM	0.506	A	0.518	A	+0.012
		PM	0.641	B	0.676	B	+0.035
2	Las Virgenes Road and Northbound 101 Freeway Ramps/Rondell Street ^b	AM	24.0	C	28.5	C	+4.5
		PM	18.7	B	19.4	B	+0.7
3	Las Virgenes Road and Southbound 101 Freeway Ramps ^b	AM	11.5	B	12.8	B	+1.3
		PM	21.1	C	24.2	C	+3.1
4	Las Virgenes Road and Agoura Road ^a	AM	0.610	B	0.693	B	+0.083
		PM	0.599	A	0.734	C	+0.135
5	Lost Hills Road and Agoura Road ^a	AM	0.501	A	0.517	A	+0.016
		PM	0.601	B	0.631	B	+0.030

Source: Overland Traffic Consultants, Inc., 2014; See Appendix F for full traffic analysis.

^a Intersections analyzed using ICU volume/capacity ratios

^b Intersections analyzed using HCM Delay seconds per vehicle

The study area intersections are projected to operate within acceptable LOS during the peak hours for future (2016) + project traffic conditions, as shown in Table 19.

**Table 19
 Future Cumulative Traffic Conditions with Project**

No.	Intersection	Peak Hour	Future (2016) without Project		Future (2016) with Project			Significant Impact?
			ICU/Delay	LOS	ICU/Delay	LOS	Change	
1	Las Virgenes Road and Mureau Road ^a	AM	0.518	A	0.521	A	+0.003	No
		PM	0.676	B	0.681	B	+0.005	No
2	Las Virgenes Road and Northbound 101 Freeway Ramps/Rondell Street ^b	AM	28.5	C	29.7	C	+1.2	No
		PM	19.4	B	19.7	B	+0.3	No
3	Las Virgenes Road and Southbound 101 Freeway Ramps ^b	AM	12.8	B	13.2	B	+0.4	No
		PM	24.2	C	26.1	C	+1.9	No
4	Las Virgenes Road and Agoura Road ^a	AM	0.693	B	0.698	B	+0.005	No
		PM	0.734	C	0.738	B	+0.004	No
5	Lost Hills Road and Agoura Road ^a	AM	0.517	A	0.518	A	+0.001	No
		PM	0.631	B	0.631	B	+0.000	No

Source: Overland Traffic Consultants, Inc., 2014; See Appendix F for full traffic analysis.

^a Intersections analyzed using ICU volume/capacity ratios

^b Intersections analyzed using HCM Delay seconds per vehicle

As shown in Tables 18 and 19, all five study intersections are currently operating at LOS C or better during the peak hours. The forecast change in operations during the AM and PM peak hours in comparing the existing to existing plus project conditions and the project to future plus cumulative conditions are determined to be less than significant at all five study intersections.



Therefore, project-related and cumulative traffic impacts would be less than significant based on the City of Calabasas intersection impact threshold criteria

LESS THAN SIGNIFICANT IMPACT

b) Would the project conflict with an applicable congestion management program, including, but not limited to level of service standards and travel demand measures, or other standards established by the county congestion management agency for designated roads or highways?

f) Would the project conflict with adopted policies, plans, or programs regarding public transit, bikeways, or pedestrian facilities, or otherwise substantially decrease the performance or safety of such facilities?

The Congestion Management program (CMP) was adopted to monitor regional traffic growth and related transportation improvements. The CMP designated a transportation network including all state highways and some arterials within the County to be monitored by local jurisdictions. If LOS standards deteriorate on the CMP network, then local jurisdictions must prepare a deficiency plan to be in conformance with the program. Local jurisdictions found to be in nonconformance with the CMP risk the loss of state gas tax funding.

For purposes of the CMP LOS analysis, an increase in the freeway volume by 150 vehicles per hour during the AM or PM peak hours in any direction requires further analysis. A substantial change in freeway segments is defined as an increase or decrease of 2% in the demand to capacity ratio when at LOS F. For purposes of CMP intersections, an increase of 50 vehicles or more during the AM or PM peak requires further analysis. The intersection of Pacific Coast Highway (PCH) and Malibu Canyon is the nearest CMP intersection. This intersection is approximately 10 miles from the project site. It is anticipated that less than eight vehicle trips would be passing through the intersection during peak hours and the proposed project's traffic impact would not exceed the CMP intersection threshold.

The proposed project may add approximately 12 single direction freeway trips in the project area 101 Freeway during the peak hours. This is below the CMP significance thresholds of 150 vehicles per hour for a potential significant freeway impact. As demonstrated in Table 20, no significant cumulative freeway traffic impact would occur. Therefore, project-related traffic impacts to the CMP would be less than significant.

The proposed project would be limited to site-specific improvements and would not damage the performance or safety of any public transit, bikeway or pedestrian facilities. Conversely, the proposed project would maintain the quality of the pedestrian environment with landscaping along Las Virgenes Road and a pedestrian path from the proposed hotel entrance to the bus stop on Las Virgenes Road. Public transportation in the project area is provided by the City of Calabasas, Metro and the LADOT. Calabasas Public Transportation provides shuttle service via routes 1, 2, and 5, and trolley service. Line 1 operates throughout the City of Calabasas seven days a week. Metro provides transit service between Warner Center and the Thousand Oaks Transit Center via Route 161 with direct service to the site as it travels along Las Virgenes Road. LADOT provides the Commuter Express line 423 connecting Newbury Park, Thousand Oaks, Agoura Hills, Calabasas, Woodland Hills and Encino with downtown Los Angeles. An existing transit stop is provided directly in front of the project site on the north east side of the



intersection of Las Virgenes Road and Rondell Street. Transit facilities include a bench, shade cover, transit signs and trash receptacle.

The proposed project would generate approximately 1,038 weekday daily trips, including 67 A.M. peak hour trips and 76 P.M. peak hour trips. Per CMP (2004) guidelines, person trips can be estimated by multiplying the total trips generated by 1.4. The trips assigned to transit may be calculated by multiplying the person trips generated by 3.5%. The proposed project would generate approximately 51 daily, 3 AM peak hour, and 4 PM peak hour daily trips. The proposed project would incrementally increase ridership, but would not adversely affect the current ridership of the transit services in the area.

The proposed project includes seven bicycle parking spaces. Sidewalks are provided along all key roadways in the project site vicinity and pedestrian crosswalks with walk lights are provided at signalized intersections in the project area. The project would also designate 6 parking spaces for the transit stop along Las Virgenes Road. The project would have no impact with respect to adopted policies, plans, or programs regarding public transit, bikeways, or pedestrian facilities, and would not otherwise substantially reduce the performance or safety of such facilities.

LESS THAN SIGNIFICANT IMPACT



**Table 20
 Freeway CMP Analysis**

Location	Time Period	Freeway Capacity	Existing 2014			Future (2016) without Project			Added Project Traffic	Future (2016) with Project			Impact	Significant?
			Volume	D/C	LOS	Volume	D/C	LOS		Volume	D/C	LOS		
Ventura Freeway	Daily		192,500			196,389			156	196,545				
	Peak Hour	20,000	14,700	0.735	D	14,997	0.750	C	12	15,009	0.750	C	0.0%	No
Location	Time Period	Freeway Capacity	Existing 2014			Future (2030) without Project			Added Project Traffic	Future (2030) with Project			Impact	Significant?
			Volume	D/C	LOS	Volume	D/C	LOS		Volume	D/C	LOS		
Ventura Freeway	Daily					223,300			156	223,456				
	Peak Hour	20,000				17,052	0.853	D	12	17,064	0.853	D	0.0%	No

Source: Overland Traffic Consultants, Inc., 2014; See Appendix F for full traffic analysis.

Note: D/C = demand over capacity



c) *Would the project result in a change in air traffic patterns, including either an increase in traffic levels or a change in location that results in substantial safety risks?*

Van Nuys Airport is the airport nearest to the project site, approximately 12 miles northeast. Implementation of the proposed project would have no effect on air traffic patterns, including either an increase in traffic levels or a change in location that results in safety risks. No impact would occur.

NO IMPACT

d) *Would the project substantially increase hazards due to a design feature (e.g., sharp curves or dangerous intersections) or incompatible use (e.g., farm equipment)?*

e) *Would the project result in inadequate emergency access?*

The project does not include any design features or incompatible uses that would increase traffic hazards. As a condition of project approval, the project would be required to provide adequate emergency access, based on Article III of the City Development Code, which includes specific site planning and project design standards intended to address such issues as traffic hazards and emergency access. In addition, the project would be subject to the LACFD and LASD review, prior to approval, to ensure that access needs are met. The project would not affect existing pedestrian facilities or conflict with adopted policies plans or programs regarding public transit. As such, impacts relating to traffic hazards and emergency access would be less than significant.

LESS THAN SIGNIFICANT IMPACT

	Potentially Significant Impact	Potentially Significant Unless Mitigation Incorporated	Less than Significant Impact	No Impact
--	---------------------------------------	---	-------------------------------------	------------------

XVII. UTILITIES AND SERVICE SYSTEMS

-- Would the project:

a) Exceed wastewater treatment requirements of the applicable Regional Water Quality Control Board?	<input type="checkbox"/>	<input type="checkbox"/>	<input checked="" type="checkbox"/>	<input type="checkbox"/>
b) Require or result in the construction of new water or wastewater treatment facilities or expansion of existing facilities, the construction of which could cause significant environmental effects?	<input type="checkbox"/>	<input type="checkbox"/>	<input checked="" type="checkbox"/>	<input type="checkbox"/>
c) Require or result in the construction of new storm water drainage facilities or expansion of existing facilities, the construction of which could cause significant environmental effects?	<input type="checkbox"/>	<input type="checkbox"/>	<input checked="" type="checkbox"/>	<input type="checkbox"/>



	Potentially Significant Impact	Potentially Significant Unless Mitigation Incorporated	Less than Significant Impact	No Impact
--	--------------------------------	--	------------------------------	-----------

XVII. UTILITIES AND SERVICE SYSTEMS

-- Would the project:

d) Have sufficient water supplies available to serve the project from existing entitlements and resources, or are new or expanded entitlements needed?	<input type="checkbox"/>	<input type="checkbox"/>	<input checked="" type="checkbox"/>	<input type="checkbox"/>
e) Result in a determination by the wastewater treatment provider which serves or may serve the project that it has adequate capacity to serve the project's projected demand in addition to the provider's existing commitments?	<input type="checkbox"/>	<input type="checkbox"/>	<input checked="" type="checkbox"/>	<input type="checkbox"/>
f) Be served by a landfill with sufficient permitted capacity to accommodate the project's solid waste disposal needs?	<input type="checkbox"/>	<input type="checkbox"/>	<input checked="" type="checkbox"/>	<input type="checkbox"/>
g) Comply with federal, state, and local statutes and regulations related to solid waste?	<input type="checkbox"/>	<input type="checkbox"/>	<input checked="" type="checkbox"/>	<input type="checkbox"/>

a) Would the project exceed wastewater treatment requirements of the applicable Regional Water Quality Control Board?

b) Would the project require or result in the construction of new water or wastewater treatment facilities or expansion of existing facilities, the construction of which could cause significant environmental effects?

e) Would the project result in a determination by the wastewater treatment provider which serves or may serve the project that it has adequate capacity to serve the project's projected demand in addition to the provider's existing commitments?

Wastewater generated in Calabasas is treated at the Tapia Water Reclamation Facility (TWRP), operated by Las Virgenes Municipal Water District (LVMWD). The TWRP has a capacity of 16 million gallons per day (mgd) and currently treats an average of 9.5 mgd (LVMWD, 2011). Therefore, there is a surplus capacity of 6.5 mgd. Wastewater generation factors from the City of Los Angeles CEQA Thresholds Guide were used to estimate the proposed project's wastewater generation. As shown in Table 21, the proposed project would generate about 16,510 gallons of wastewater per day (0.017 mgd).



**Table 21
 Projected Wastewater Generation**

Land Use	Units	Wastewater Generation Factor	Total Wastewater Flow (Gallons Per Day)
Hotel	127 rooms	130 gpd/room	16,510

gpd = gallons per day sf = square feet

Source: City of Los Angeles, CEQA Thresholds Guide Document, 2006.

Wastewater generated by the proposed project would account for approximately 0.3% of the Tapia Water Reclamation Facility’s available treatment capacity. Therefore, impacts related to wastewater treatment would be **less than significant** and further analysis of these issues is not warranted.

LESS THAN SIGNIFICANT IMPACT

c) Would the project require or result in the construction of new storm water drainage facilities or expansion of existing facilities, the construction of which could cause significant environmental effects?

As discussed in Section IX, *Hydrology and Water Quality*, the project site currently consists of pervious surfaces. The area of impervious surface would increase with the proposed project. Stormwater drainage in the County is provided by a network of regional drainage channels and local drainage facilities. Surface water is deposited into regional channels, which are owned and maintained by the County. The proposed project would be required to comply with the Los Angeles County Areawide MS4 permit, which requires that the amount of runoff from the site must be the same before and after construction of a project. The proposed project would include a drainage basin to capture the difference between pre- and post-project flows; therefore, the proposed project would not increase peak runoff into the storm drain system. The on-site storm drain system would be designed, installed, and maintained per County of Los Angeles Department of Public Works standards. Because the project would be required to include site drainage systems meeting standards and provisions set forth by the City of Calabasas and the County of Los Angeles, impacts would be less than significant.

LESS THAN SIGNIFICANT IMPACT

d) Would the project have sufficient water supplies available to serve the project from existing entitlements and resources, or are new or expanded entitlements needed?

The Las Virgenes Municipal Water District (LVMWD) provides water service in Calabasas. The reliability of the LVMWD’s water supply is currently dependent on the reliability of its imported water supplies, which are managed and delivered by the Metropolitan Water District of Southern California (MWD). As shown in Table 22, the proposed project would generate demand for about 19,812 gallons of water per day or 22 acre-feet per year.



**Table 22
 Project Water Demand**

Land Use	Units	Demand Factor	Demand (Gallons Per Day)	Demand (Acre-Feet Per Year)
Hotel	127 rooms	156 gpd/room	19,812	22

gpd = gallons per day

One acre-foot = 325,850 gallons

Source: City of Los Angeles, CEQA Thresholds Guide Document, 2006.

Water demand is assumed to be 120% of wastewater generation, as shown in Table 21, in order to account for landscape irrigation.

Table 23 compares LVMWD water supplies to forecast demand under normal year conditions and multiple dry years based on the LVMWD’s 2010 Urban Water Management Plan. The LVMWD has sufficient water supplies to meet forecast demand for the normal year as well as dry years 1, 2, and 3 of a multiple dry year scenario.

**Table 23
 LVMWD Water Supply and Demand in Normal Year
 and Single and Multiple Dry Years (Acre Feet)**

Normal Year	2015	2020	2025	2030	2035
Supply Totals	46,553	49,591	54,434	54,163	52,845
Demand Totals	28,829	28,219	30,280	32,304	33,252
Reserves (Supply – Demand)	17,724	21,372	24,154	21,859	19,953
Multiple Dry Year No. 1	2015	2020	2025	2030	2035
Supply Totals	34,132	35,979	38,479	39,498	39,384
Demand Totals	33,981	33,261	35,690	38,077	39,193
Reserves (Supply – Demand)	152	2,718	2,788	1,421	190
Multiple Dry Year No. 2	2015	2020	2025	2030	2035
Supply Totals	33,986	36,484	38,973	39,730	39,615
Demand Totals	33,837	33,747	36,168	38,300	39,423
Reserves (Supply – Demand)	149	2,737	2,806	1,430	191
Multiple Dry Year No. 3	2015	2020	2025	2030	2035
Supply Totals	33,839	36,988	39,468	39,961	39,846
Demand Totals	33,693	34,233	36,645	38,523	39,653
Reserves (Supply – Demand)	147	2,755	2,823	1,438	192

Source: Las Virgenes Municipal Water District, 2010 Urban Water Management Plan, June 2011.

The proposed project would generate demand for about 22 acre-feet of water per year. The proposed project is consistent with the level of development that was anticipated for the project



site under the 2030 General Plan and the LVMWD 2010 UWMP water demand forecasts account for growth anticipated under the 2030 General Plan. Consequently, the increase in water demand associated with the proposed project can be accommodated with existing and planned supplies.

Due to the current state-wide drought, the State Water Resources Control Board (SWRCB) adopted new water conservation regulations (Resolution 2014-0038) in July 2014, including select prohibitions for all water users and required actions for all water agencies. On April 1, 2015, Governor Brown issued Executive Order B-29-15, which ordered the SWRCB to impose restrictions to achieve a statewide 25% reduction in potable urban water usage through February 28, 2016. Executive Order B-29-15 states that “these restrictions will require water suppliers to California’s cities and towns to reduce usage as compared to the amount used in 2013” (State of California, Executive Order B-29-15, April 2015). The SWRCB adopted an emergency conservation regulation in accordance with the Governor’s directive on May 5, 2015, the provisions of which went into effect on May 18, 2015 (SWRCB, June 2015). According to SWRCB data, the LVMWD must cut its water usage by 36% (State Water Resources Control Board, June 11, 2015).

In response to the drought, the LVMWD has adopted a number of water conservation measures. Measures include restricting outdoor irrigation to two days a week and prohibiting irrigation between 10 A.M. and 5 P.M. and during or within 24 hours of rainfall. Irrigation runoff into streets, gutters, or other adjacent properties is also prohibited, as is the washing down of sidewalks and driveways. Additional measures include requiring a trigger nozzle for home car washing and requiring fountains and water features to use a recirculating system. Lastly, hotels and motels must give multi-night guests the option to reuse towels and linens during their stay to cut down on water used by washing machines. Violations of water conservation measures may be subject to a fine ranging from \$100 for the second violation to \$500 for the fourth violation by the LVMWD. For the fifth violation, LVMWD may terminate service to a property or install a flow restriction device.

Additionally, in response to the need for greater water-use efficiency and to encourage water use reduction during droughts, LVMWD is developing a "budget-based water rate" billing structure that provides each customer with a personalized water budget designed to meet their specific indoor and outdoor water needs. The new program will replace the District’s existing "fixed tier" rate structure in 2016.

Despite the current drought conditions, the increase in water demand associated with the proposed project can be accommodated with existing and planned supplies. The proposed project would be required to comply with any existing or future restrictions on water use that the LVMWD implements, which may include additional restrictions on landscape irrigation and promotion of non-potable water use, such as grey water, as described in SWRCB’s Resolution 2014-0038. The proposed project would also be subject to the LVMWD’s budget-based water rate billing structure, which is designed to encourage water use reductions. Impacts to water supply would, therefore, be less than significant.

LESS THAN SIGNIFICANT IMPACT



f) *Would the project be served by a landfill with sufficient permitted capacity to accommodate the project’s solid waste disposal needs?*

g) *Would the project comply with federal, state, and local statutes and regulations related to solid waste?*

The Calabasas Sanitary Landfill, located adjacent to U.S. Highway 101 on Lost Hills Road, would receive solid waste generated by the proposed project. The total capacity of the Calabasas Landfill is 69.3 million cubic yards and its remaining capacity is approximately 18.1 million cubic yards (CalRecycle, SWIS, 2014). An average of 581 tons of waste is deposited in the landfill daily, with a permitted maximum daily capacity of 3,500 tons per day (CalRecycle, 2013 Landfill Summary Tonnage Report, 2014). Thus, the average daily surplus is 2,919 tons per day. As shown in Table 24, the proposed project would generate about 508 pounds, or 0.3 tons, of solid waste per day before mandated diversion.

**Table 24
 Project Solid Waste Generation**

Land Use	Area	Generation Factor	Solid Waste Generated (lbs/day)	Solid Waste Generated (tons/day)
Hotel	127 rooms	4 lbs/room/day	508	0.3

* Note solid waste generated as shown herein does not include mandated diversion requirements.

sf = square feet

Source: CalRecycle, 2013. <http://www.calrecycle.ca.gov/wastechar/wastegenrates/Residential.htm>,
<http://www.calrecycle.ca.gov/WasteChar/WasteGenRates/Commercial.htm>,
<http://www.calrecycle.ca.gov/WasteChar/WasteGenRates/Service.htm>.

The proposed project would be subject to federal, state, and local regulations related to solid waste, recycling, and water conservation, including the City’s 75% waste diversion rate goal, which would reduce the total amount generated to about 127 pounds per day or 0.06 tons per day. The Calabasas Landfill has a surplus of 2,919 tons per day, which the proposed project would reduce by 0.002%. Therefore, the landfill has adequate capacity to serve the proposed project. Impacts would be less than significant.

LESS THAN SIGNIFICANT IMPACT



	Potentially Significant Impact	Potentially Significant Unless Mitigation Incorporated	Less than Significant Impact	No Impact
--	--------------------------------	--	------------------------------	-----------

XVIII. MANDATORY FINDINGS OF SIGNIFICANCE

a) Does the project have the potential to substantially reduce the habitat of a fish or wildlife species, cause a fish or wildlife population to drop below self- sustaining levels, eliminate a plant or animal community, reduce the number or restrict the range of a rare or endangered plant or animal or eliminate important examples of the major periods of California history or prehistory?	<input type="checkbox"/>	<input checked="" type="checkbox"/>	<input type="checkbox"/>	<input type="checkbox"/>
b) Does the project have impacts that are individually limited, but cumulatively considerable? (“Cumulatively considerable” means that the incremental effects of a project are considerable when viewed in connection with the effects of past projects, the effects of other current projects, and the effects of probable future projects)?	<input type="checkbox"/>	<input type="checkbox"/>	<input checked="" type="checkbox"/>	<input type="checkbox"/>
c) Does the project have environmental effects which will cause substantial adverse effects on human beings, either directly or indirectly?	<input type="checkbox"/>	<input type="checkbox"/>	<input checked="" type="checkbox"/>	<input type="checkbox"/>

a) Does the project have the potential to substantially reduce the habitat of a fish or wildlife species, cause a fish or wildlife population to drop below self- sustaining levels, eliminate a plant or animal community, reduce the number or restrict the range of a rare or endangered plant or animal or eliminate important examples of the major periods of California history or prehistory?

As discussed under Section IV, *Biological Resources*, and Section V, *Cultural Resources*, implementation of the proposed project would have a less than significant impact on cultural resources and a potentially significant impact to wildlife corridors unless mitigation is incorporated. Implementation of mitigation measures BIO-1 and BIO-2 would reduce impacts to biological resources to a less than significant level.

LESS THAN SIGNIFICANT IMPACT

b) Does the project have impacts that are individually limited, but cumulatively considerable? (“Cumulatively considerable” means that the incremental effects of a project are considerable when viewed in connection with the effects of past projects, the effects of other current projects, and the effects of probable future projects)?



As described in the discussion of environmental checklist Sections I through XVII, the project would have no impact or a less than significant impact with respect to all environmental issues. Cumulative impacts of several resource areas have been addressed in the individual resource sections above: Aesthetics, Air Quality, Biological Resources, Greenhouse Gases, Utilities and Service Systems (water supply and solid waste), and Transportation/Traffic (See CEQA Guidelines Section 15064(h)(3)). Some of the other resource areas (agricultural and mineral) were determined to have no impact in comparison to existing conditions and therefore would not contribute to cumulative impacts. The Canyon Oaks project located south of the proposed project may affect other resource areas, however, these cumulative impacts were considered in the context of biological resources. As such, cumulative impacts would be less than significant (not cumulatively considerable).

LESS THAN SIGNIFICANT IMPACT

c) Does the project have environmental effects which will cause substantial adverse effects on human beings, either directly or indirectly?

In general, impacts to human beings are associated with air quality, hazards and hazardous materials, and noise impacts. As detailed in the preceding sections, the proposed project would not result, either directly or indirectly, in adverse hazards related to air quality, hazardous materials or noise. Compliance with applicable rules and regulations would reduce potential impacts on human beings to a less than significant level.

LESS THAN SIGNIFICANT IMPACT



REFERENCES

Bibliography

Calabasas, City of, 2030 General Plan, December 2008.

Calabasas, City of, 2030 General Plan Final Environmental Impact Report (FEIR), December 2008.

Calabasas, City of, June 2012, Historic Place of the Month: The De Anza Trail, website: <http://www.cityofcalabasas.com/historic/june2012.html>. Accessed March 2015.

Calabasas, City of. Municipal Code, <http://library.municode.com/index.aspx?clientId=16235&stateId=5&stateName=California>, accessed online March 2015.

Calabasas, City of. Website: Projects, Plans & Reports in the City of Calabasas. Accessed at <http://www.cityofcalabasas.com/projects.html>. Accessed on May 2015.

Calabasas Library, 2013, Library 2012-2013 Annual Report, <http://www.cityofcalabasas.com/library/pdf/annualreport2012-2013.pdf>, accessed March 2015.

California Air Pollution Control Officers Association (CAPCOA), *CEQA & Climate Change*, January 2008, website: <http://www.capcoa.org/wp-content/uploads/downloads/2010/05/CAPCOA-White-Paper.pdf>, accessed March 2015.

California Air Resources Board, State and National Area Designations Maps, <http://www.arb.ca.gov/degis/adm/adm.htm>, accessed March 2015.

California Department of Finance, Population Estimates for Cities, Counties, and the State with Annual Percent Change – January 2014.

California Division of Land Resource Protection, Farmland Mapping and Monitoring Program, <http://www.consrv.ca.gov/dlrp/FMMP/index.htm>, accessed online February 2015.

California Climate Action Registry (CCAR) General Reporting Protocol, *Reporting Entity-Wide Greenhouse Gas Emissions*, Version 3.1, January 2009.

California Energy Commission, *Environmental Health and Equity Impacts from Climate Change and Mitigation Policies in California: A Review of the Literature*, March 2009.

California Energy Commission, Cal-Adapt website: <http://cal-adapt.org/>. Accessed March 2015.

California Fish and Wildlife, BIOS Database Version 5.26.19a, website: <https://map.dfg.ca.gov/bios/>. Accessed March 13, 2015.



CalRecycle, 2013 Landfill Summary Tonnage Report, 2014.

CalRecycle, Solid Waste Information System (SWIS), 2014,
<http://www.calrecycle.ca.gov/SWFacilities/Directory/Search.aspx>, accessed March 2015.

Caltrans, California Scenic Highway Program, 2012,
http://www.dot.ca.gov/hq/LandArch/scenic_highways/scenic_hwy.htm, accessed March 2015.

Comprehensive Environmental Response, Compensation, and Liability Information System (CERCLIS) database, <http://www.epa.gov/superfund/sites/cursites/>, accessed online March 2015.

Cortese list of Hazardous Waste and Substances Sites,
http://www.dtsc.ca.gov/SiteCleanup/Cortese_List.cfm, accessed online March 2015.

County of Los Angeles Fire Department, <http://www.fire.lacounty.gov/>, accessed online March 2015.

Department of Toxic Substances Control's Site Mitigation and Brownfields Database
<http://www.epa.gov/enviro/html/bms/index2.html>, accessed online March 2015.

Federal Railroad Administration, *Human Response to Different Levels of Groundborne Vibration*, 1998.

Federal Transit Administration (FTA), *Transit Noise and Vibration Impact Assessment*, May 2006.

Geotracker search for leaking underground fuel tanks, Spills-Leaks-Investigations-Cleanups (SLIC) and Landfill sites, <http://geotracker.swrcb.ca.gov/search/>, accessed online March 2015.

Institute of Transportation Engineers (ITE), *Trip Generation*, 9th Edition, 2012.

Las Virgenes Municipal Water District, 2010 Urban Water Management Plan, June 2011.

Las Virgenes Unified School District, <http://corp.lvusd.org/> accessed online March 2015.

Los Angeles, City of, CEQA Thresholds Guide Document, Exhibit M.2-12
(<http://environmentla.com/programs/thresholdsguide.htm>), 2006.

Los Angeles, County of, GIS-NET3 Significant Ecological Areas. Accessed at
http://rpgis.isd.lacounty.gov/GIS-NET3_Public/Viewer.html. Accessed June 16, 2015.

McKenna, et al., A Cultural Resources Investigation for the Proposed Canyon Oaks Project Area in the City of Calabasas, Los Angeles County, California, November 8, 2013.



Overland Traffic Consultants, Inc., Traffic Impact Analysis for Rondell Oasis Hotel, December 2014.

South Coast Air Quality Management District (SCAQMD), CEQA Air Quality Handbook, 1993.

SCAQMD, White Paper on Potential Control Strategies to Address Cumulative Impacts from Air Pollution, Appendix D – Cumulative Impact Analysis Requirements Pursuant to CEQA, August 2003. Website: <http://www.aqmd.gov/docs/default-source/Agendas/Environmental-Justice/cumulative-impacts-working-group/cumulative-impacts-white-paper-appendix.pdf?sfvrsn=4>

SCAQMD, Final Localized Significance Threshold Methodology, revised July 2008. Website: <http://www.aqmd.gov/docs/default-source/ceqa/handbook/localized-significance-thresholds/final-lst-methodology-document.pdf?sfvrsn=2>

SCAQMD, Draft AQMD Staff CEQA Greenhouse Gas Significance Threshold, August 2008. Website: http://www.aqmd.gov/ceqa/handbook/GHG/2008/aug27mtg/GHGproposal_augmtg.pdf

SCAQMD, Greenhouse Gas CEQA Significance Threshold Stakeholder Working Group Meeting #8: “Staff’s Interim GHG Proposal, 2009. Website: <http://www.aqmd.gov/docs/default-source/ceqa/handbook/greenhouse-gases-%28ghg%29-ceqa-significance-thresholds/year-2008-2009/ghg-meeting-8/ghg-meeting-8-main-presentation.pdf?sfvrsn=2>

South Coast Air Quality Management District, Greenhouse Gas CEQA Significance Threshold Stakeholder Working Group Meeting #15: “Proposed Tier 3 Quantitative Thresholds – Option 1”, September 2010. Website: <http://www.aqmd.gov/ceqa/handbook/GHG/2010/sept28mtg/ghgmtg15-web.pdf>

SCAQMD, *Air Quality Management Plan*, 2012. Website: <http://www.aqmd.gov/aqmp/2012aqmp/index.htm>

Southern California Association of Governments (SCAG), Employment Density Study Summary Report, October 2001. Website: <http://www.mwcog.org/uploads/committee-documents/YV5WXFhW20110503134223.pdf>. Accessed on February 27, 2015.

SCAG, Regional Transportation Plan 2012-2035, Growth Forecast Appendix, April 2012.

State of California. Executive Order B-29-15. Accessed April 9, 2015. Accessed at http://gov.ca.gov/docs/4.1.15_Executive_Order.pdf.

State Water Resources Control Board. State Water Board. Drought Year Water Actions, Proposed Emergency Conservation Regulation Schedule. Accessed April 9, 2015. Accessed at http://www.waterboards.ca.gov/waterrights/water_issues/programs/drought/executive_order_schedule.shtml.



State Water Resources Control Board. Urban Water Suppliers Conservation Tiers. June 11, 2015. Accessed at http://www.waterboards.ca.gov/water_issues/programs/conservation_portal/docs/supplier_tiers.pdf. Accessed on June 16, 2015.

State Water Resources Control Board. Emergency Conservation Regulation. Accessed June 16, 2015. Accessed at http://www.waterboards.ca.gov/water_issues/programs/conservation_portal/emergency_regulation.shtml

U.S. Environmental Protection Agency (EPA), *Noise from Construction Equipment and Operations, Building Equipment, and Home Appliances*, 1971.

Willdan Engineering and GeoSoils Consultants, Inc., Response to City of Calabasas Review Letter, Rondell Oasis Hotel, February 5, 2015.

Persons Contacted

Buck, Lorraine, Planning Analyst, Los Angeles County Fire Department, contacted on March 10, 2015.

Beder, Kelly, Business Services, Las Virgenes Unified School District, contacted on March 10, 2015.

Davoren, Patrick S., Captain Malibu/Lost Hills Station, County of Los Angeles Sheriff's Department, letter dated June 11, 2015.



Appendix A
Oak Tree Report



OAK TREE REPORT

SUBJECT

26300 Rondell Street Project

PREPARED FOR

Rondell Oasis, LLC
P.O. Box 6528
Malibu, CA 90264

PREPARED BY

L. NEWMAN DESIGN GROUP, INC.
ASLA, California State License #2464
ISA Certified Arborist WE-6820A
31300 Via Colinas, Suite 104
Westlake Village, CA 91362-3992
E-Mail: *lndg@lndg.net*
Ph.: (818) 991-5056
Fx.: (818) 991-3478



Date: April 27, 2015
Revised Date: June 8, 2015
LNDG Project No.: 200-545

COPYRIGHT NOTICE

This Document is Owned by and is the Sole and Exclusive Property of L. NEWMAN DESIGN GROUP, INC. All Information Contained in the Document is for Use on the Specified Project and shall not be Used/Copied without the Expressed Written Permission of L. NEWMAN DESIGN GROUP, INC.

OBJECTIVES

The objective of this report is to discuss the anticipated impact on this project's oak tree resource within or near the limit of work for this project. This involved:

1. Ascertaining the impacts that will occur due to the proposed grading and construction (refer to **OAK TREE LOCATION MAP**);
2. Providing guidance to minimize encroachments of the saved trees.

METHODS of STUDY

Qualifications of the oak trees were accomplished by the use of our standard visual survey, as completed by L. NEWMAN DESIGN GROUP, INC. (LNDG) on April 6, 2015. The following was performed:

1. Live tree trunks were measured at 4½' above mean natural grade and they were assessed for plant quality. Trees included in the tree inventory were within or near the limit of work and had reached the status of a protected tree, i.e., those that had at least a 2-inch trunk diameter or, measured at 12 inches above grade, at least a 1-inch trunk diameter);
2. The trees were tagged with numbered, metal tags. These tags are affixed to the sides of the trees and correspond to those numbers on the **OAK TREE LOCATION MAP**;
3. Drip lines (the outermost edge of the tree's canopy) were field measured at eight compass directions equidistant around the circumference of the tree. The minimum clearance from the present grade to the bottom of the canopy at each of the points was estimated.
4. All of the inventoried trees were previously land surveyed, except for trees 3, 4, and 5, and are shown on the topographic map/grading plan (scale: 1"=30'). The locations of 3, 4, and 5 were estimated by LNDG in the field. Refer to the **OAK TREE LOCATION MAP** included herein for the tree locations.

PROJECT LOCATION

The site, 26300 Rondell Street, is located east of the existing Las Virgenes freeway eastbound onramp in the City of Calabasas.

OAK SPECIES

There are 9 oak trees addressed in this phase of the project. 5 are *Quercus agrifolia* (coast live oak) and 4 are *Quercus lobata* (valley oak).

OAK TREE ORDINANCE (excerpted from the City's Oak Tree Preservation and Protection Guidelines.)

The City lies in a unique area of Los Angeles County, the beauty of which is greatly enhanced by the presence of large numbers of majestic Oak trees. Development of the area has resulted in the removal of a great number of these trees. Further uncontrolled and indiscriminate destruction of Oak trees would detrimentally affect the safety and welfare of the citizens of Calabasas. This preservation program outlined in this Ordinance contributes to the welfare and aesthetics of the community and retains the great historical and environmental value of these trees.

This ordinance sets forth the policy of the City to require the preservation of all healthy Oak trees unless reasonable and conforming use of the property justifies the removal, cutting, pruning and/or encroachment into the Protected Zone of an Oak tree. The Protected Zone shall mean that area within the dripline of an Oak tree and extending there from to a point at least 5' outside the dripline, or 15' from the trunk(s) of a tree, whichever distance is greater.

The major thrust of the Oak Tree Policy was established to recognize Oak trees as significant, historical, aesthetic and valuable ecological resources, and as one of the most picturesque trees in Los Angeles County, lending beauty and charm to the natural and man-made landscape, enhancing the value of property, and the character of the communities in which they exist. In addition, the Oak Tree Policy intends to create favorable conditions for the preservation and propagation of this unique, threatened plant heritage, particularly those trees which may be classified as 'Heritage Oak Trees', for the benefit of current and future residents of Calabasas. It is the intent of the Oak Tree Policy to maintain and enhance the general health, safety, and welfare by assisting in counteracting air pollution, and in minimizing soil erosion and other related environmental damages. The Oak Tree Policy is also intended to preserve and enhance property values by conserving and adding to the distinctive and unique aesthetic character of many areas of Calabasas in which Oak trees are indigenous.

RESULTS of STUDY

1. **Physiological Condition of the Oaks**

The physiological condition of the oak trees is detailed in the **SUMMARY of FIELD OBSERVATIONS**. The trees are generally healthy. All recommendations made in this report are based on the condition of the trees as of the date of the field work.

2. **Summary of Data/Plan Review**

- A. Oak trees 1 and 6 – 9 are located outside of the property line of this project. Only trees 1, 2 and 7 will be encroached by grading at the perimeter of the site development. No oak trees will be removed.
- B. The following 3 trees will be encroached by the project:

Tree #	Reason for Encroachment
1	This tree will be encroached on the east side of the trunk by the edge of the proposed pavement, 10 feet from the trunk. The grading operation and construction of the parking lot will take the encroachment a few feet closer to the trunk. The new pavement will be at grade so the impact to the tree should be minor. The estimated area of encroachment will be approximately 3,400 square feet or 43% of the area of the protected zone. Pruning will be limited to that root pruning necessary to grade and construct the parking lot.
2	This tree will be encroached slightly by the construction of the concrete v-ditch at the top of the proposed manufactured slope at the perimeter of protected zone. The area of the encroachment will be approximately 400 square feet, 5% of the area of the protected zone. The extent of the excavation for the v-ditch will be 40 feet from the trunk. Pruning will be limited to that root pruning necessary to grade and construct the v-ditch.
7	A proposed deflection wall is proposed that will be constructed approximately 35 feet for the trunk. The area of this construction will be 650 square feet, approximately 8% of the area of the protected zone. Pruning will be limited to that root pruning necessary to excavate for the wall footing and swale.

- C. Drip lines on the **OAK TREE LOCATION MAP** graphically represent the dripline measurements made in the field.
- D. Oak trees 1, 2, 6 and 7 are heritage trees.

OAK TREE PRESERVATION PROGRAM

1. **General Oak Tree Protection**

- A. Copies of the oak tree report and the City of Calabasas' approved oak tree permit shall be kept on-site during all construction.
- B. The applicant's oak tree consultant shall be notified 48 hours prior to the commencement of any work within the protected zone of any oak tree. Any work done within the protected zone of any protected oak tree that requires an observer to insure protection against damage to the oak trees shall be under the observation of a certified arborist.
- C. Trees that are to be preserved on the site during construction shall be fenced at the location of their protected zones or at the limit of grading with a temporary chain link fence prior to commencement of grading.
- D. Trees shall be protected from construction and paving machinery including but not limited to wounding of branches and roots, compaction of soil within the protected zone, and damage to the foliage by engine exhaust.
- E. No activity, such as vehicles, equipment, or building materials storage, deposit of debris and trash, or parking shall be allowed within the protected zones of any oak tree at any time.

2. **Grading within the Protected Zones of Oak Trees**

- A. Hand trenching shall be done at the limit of the proposed grading to uncover roots within the protected zones of oak trees to be preserved in place allowing them to be properly and cleanly pruned prior to grade work. This work shall be done under the observation of **LNDG**.
- B. The City requirement to hand-dig any approved excavation within the drip line of oak trees is designed to avoid irreparable root damage. The purpose is to locate and expose roots that must be pruned and to carefully prune them, thereby avoiding the ripping and tearing caused with the use of backhoe or other excavation equipment. Therefore, a **WORK PROCEDURES PROGRAM** is proposed to execute the work with precise and controlled methodology that avoids indiscriminant damage.

WORK PROCEDURES PROGRAM SPECIFICS

1. **Preparation Phase**

- A. During the pre-construction on-site survey and staking to provide layout control for the proposed improvements, the precise location of any improvement directly affecting any oak tree that is to be preserved in place shall be identified with monument stakes.

2. **Execution Phase**

A. Protective Fencing:

See “General Oak Tree Protection” above for the intent of the fencing plan. The oak trees that are to be preserved on the site shall be kept fenced during the construction operation (as shown on the Oak Tree Location Map) with a 5-foot high, temporary, chain-link fence for protection at all times when construction activities are taking place. The chain-link fence must be in place prior to the commencement of grading. The fence shall remain during all phases of construction. Damaged fencing shall be immediately replaced or repaired.

B. Pruning:

Pruning shall be performed before grading to avoid conflict between oak trees and excavation/grading equipment. This action should eliminate the potential for broken branches resulting from equipment. No above-ground (branch) pruning is anticipated. Pruning shall be done in strict compliance with ISA pruning standards.

C. Excavation:

It is not possible to develop this site without some conflict between the trees and the proposed improvements. The conflict relates to both the aerial canopy and the root structure of oak trees. The goal is to minimize and to control such damage. This can be accomplished as follows:

- i. Define the area of excavation and the direction of the pioneering for the excavation that occurs within the drip line of an oak tree.
- ii. After pruning roots as described in Section 2B above, it may be necessary to utilize small equipment to remove the soil above the primary root structure under the immediate direction of LNDG. Stop this effort upon encountering roots of significant size.
- iii. Prune roots to the required depth using standard, sterile, mechanical root pruning equipment accompanied by hand work. In the case of a roadbed, prune the roots on each side of the road as close to the improvements as possible. In the case of the storm sewer Improvements, cut the roots on each side of the proposed trench in a similar way to the required depth. Follow excavation by hand pruning (with sterilized equipment) the exposed roots.
- iv. This method will minimize root damage from excavation equipment pulling on roots in a lateral direction from their path of travel. Pruned roots shall be hand sawn, using sterilized equipment, with a clean cut, at a 45 degree angle facing downward and shall not be sealed.
- v. Place all excavation spoils outside of the protected zone of the tree.

D. Other protective measures:

- i. Protect oak trees by not wounding them. Nailing of any thing to a tree must be avoided.
- ii. The potential for breaking of branches by mechanical equipment should be anticipated. Notify LNDG with a request for an evaluation and recommendation.
- iii. It is important to leave the natural leaf litter that exists beneath an oak tree.
- iv. No chemicals such as herbicides shall be used upstream and within one hundred feet of any oak tree protected zone.

- v. Oak trees do not usually require supplemental watering but in during the current drought, the irrigation of tree 1 may be recommended because of the anticipated impact to its root system.
- vi. If grading is completed other than during the rainy season, dust deposited on the foliage of oaks must be hosed off so that the growth processes of the tree are not disrupted.

NOTICE OF DISCLAIMER:

This report represents the independent opinion of the signatory consultant (L. NEWMAN DESIGN GROUP, INC.). The tree(s) discussed herein was/were generally reviewed for physical, biological function and aesthetic conditions. This examination was conducted in accordance with presently accepted industry procedures, which are a ground-plane macro-visual observation only. No extensive micro-biological, soil-root excavations, upper crown examination nor internal tree investigations were conducted and therefore, the reporting herein reflects the overall visual appearance of the tree(s) on the date reviewed and no warranty is implied as to the potential failure, health or demise of any part or of whole of any tree described in the report. Records may not remain accurate after our inspection due to unknown causes of changeable deterioration of the reviewed site.

Sincerely,

L. NEWMAN DESIGN GROUP, INC.
ASLA, California State License #2464



John Oblinger
ISA Certified Arborist WE-6820A
ISA Tree Risk Assessor Qualified

OAK TREE PHOTOGRAPHS



Oak tree 1 facing northwest.



Oak tree 2 facing southeast.



Oak trees 3,4, and 5 facing southeast.



Oak tree 6 southeast.

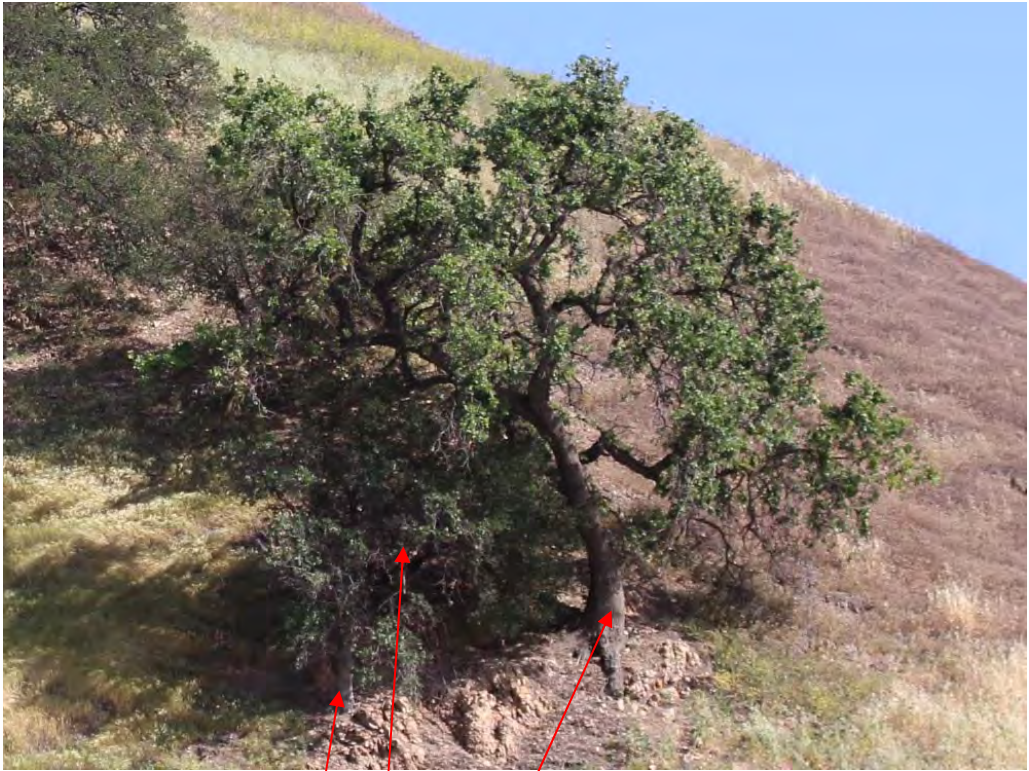

Oak trees 9,8, and 7 facing southeast.



Oak trees 9 to 2 and other trees beyond range of project, facing southeast.

SUMMARY of FIELD OBSERVATIONS

INSPECTION NOTICE

The following information was observed on the date(s) indicated herein, and should only be considered true at the time of field inspection.

SUMMARY OF FIELD OBSERVATIONS

SPECIES	TREE NUMBER									
	1	2	3	4	5	6	7	8	9	
FORM	<i>Quercus agrifolia</i>		X	X	X	X		X		
	<i>Quercus lobata</i>	X					X	X		X
	<i>Quercus berberidifolia</i>									
	TREE HT. (ESTIMATED)	25'	45'	8'	8'	9'	25'	30'	15'	12'
LEAN (ANGLE)										
TRUNK DIAMETERS	12"	48"	13 1/4"	2"	1 3/4"	36"	20"	7"	10"	
	9"		16"				16"	7"		
	8"		1"							
	4"									
PHYSICAL CONDITION	TRUNK CAVITY		X				X			X
	TRUNK EXUDATION									
	TRUNK DAMAGE									
	BURIED ROOT COLLAR									
	EXPOSED ROOTS							X	X	
	WEAK CROTCH(ES)						X			
	FUNGAL DISEASE									
	INSECT/MITE DAMAGE		X							
	NEW/OLD FIRE DAMAGE		O				O			
	BRANCH CAVITIES	X					X			
	MAINSTEM DIEBACK									
	TWIG/BRANCH DIEBACK	X	X				X			
	EPICORMIC GROWTH						X			
	THIN FOLIAGE	X					X			X
	VIGOR (GOOD/MOD/POOR)	M	M	G	G	G	M	M	G	M
TERRAIN - SLOPED/LEVEL	S	S	S	S	S	S	S	S	S	
RATING	HERITAGE	X	X				X	X		
	HEALTH	G	C	B	B	B	C	C	C	C
	AESTHETICS/COMFORMITY	C	B	B	B	B	C	C	C	C
TREAT- MENT	REMOVE DEADWOOD									
	INSECT/DISEASE TREAT									

Topped by utility peering

3' trunk until it divides at top

Pre hive. Trunk is hollow. Structurally weak. Not accessible. No top.

DRIP LINE MEASUREMENTS

INSPECTION NOTICE

The following information was observed on the date(s) indicated herein, and should only be considered true at the time of field inspection.

DRIPLINE MEASUREMENTS

TREE No.	N	NE	E	SE	S	SW	W	NW
1	21	11	11	6	25	15	12	20
HEIGHT TO CANOPY	15	9	9	15	18	18	18	15
2	35	36	36	35	33	35	35	35
HEIGHT TO CANOPY	8	3	1	1	1	6	1	1
3	4	4	4	4	4	4	4	4
HEIGHT TO CANOPY	1	1	1	1	1	1	1	1
4	3	3	3	3	3	3	3	3
HEIGHT TO CANOPY	1	1	1	1	1	1	1	1
5	4	4	4	4	3	3	2	3
HEIGHT TO CANOPY	1	1	1	1	1	1	1	1
6	18	27	20	8	7	30	20	18
HEIGHT TO CANOPY	10	8	2	2	6	6	6	8
7	20	20	25	23	26	22	20	20
HEIGHT TO CANOPY	15	15	15	15	1	5	15	15
8	10	5	5	6	6	11	15	13
HEIGHT TO CANOPY	6	2	2	1	1	1	2	8
9	5	4	3	3	5	8	8	8
HEIGHT TO CANOPY	6	6	3	4	4	6	6	6
HEIGHT TO CANOPY								

JOB No.

DATE:

PAGE No

DEFINITIONS

SUMMARY of FIELD OBSERVATIONS DEFINITIONS

INTRODUCTION

Familiarity with the following definitions is necessary to the basic understanding of the tree ordinance, this tree report, and of the procedures used to evaluate the trees and the site conditions. There are numerous diseases and insects that frequently attack trees. A long discourse in plant pathology or entomology is not a prerequisite to develop a basic understanding of the effects of disease and insects upon living plant tissue but a basic knowledge of disease and insects should include an understanding of the following definitions:

FORM

1. **Tree Number** - each protected tree in the field has been assigned a number that corresponds to a tree location on the "Tree Location Map".
2. **Species** - is the type of tree that is being evaluated.
3. **Number of Trunks** - as measured in accordance to the ordinance existing at the time of evaluation.
4. **Diameter of Trunks** - as measured at 4½' above mean natural grade.
5. **Tree Height** - is the approximate height of each numbered, evaluated tree.
6. **Leaning** - is the direction the tree is inclined from the natural vertical position.

PHYSICAL CONDITION

1. **Trunk Cavity/Damage** - A **Cavity** is a hollow area in the trunk, usually due to wood decay. **Damage** is a damaged area on the trunk, usually due to an external force onto the tree.
2. **Exposed Roots** - roots exposed near tree; e.g. in creek bed.
3. **Exfoliating Bark** - the flaking off of bark from trunk, branches and/or twigs.
4. **Water Pocket** - pockets formed at branch crotches that can hold water and possibly weaken the tree's structure (possible hazard).
5. **Exudation** - the issuance or expelling of liquid, usually from wounds.
6. **Fruiting Bodies** - are the external signs (i.e. mushrooms, conks) of internal wood decay.
7. **Insect/Mite Damage** - is some form of damage to the parts of the tree caused by insects or mites (i.e. scale, caterpillars, weevils, borers, mites, etc.).
8. **Galls/Oak Pit Scale** - **Galls** are abnormal growth (tumors) on the tree, which may be caused by insects, mites, bacteria, etc. **Oak Pit Scale** has a severe weakening effect on the twigs, sometimes resulting in their death. When the scale settles on the twig, a swelling of the twig tissue occurs so that the insect, in effect, is in a pit, hence, the name.
9. **Fire Damage** - each tree is rated on the amount of burn it has received. These are:

<u>Category</u>	<u>Percent of Tree Burned</u>
Slight (S)	0% - 25%
Moderate (M)	26% - 75%
Heavy (H)	76% - 100%
Complete (C)	Burned to the ground

DEFINITIONS

General Trees

Page 2 of 3

- A. A check mark only, indicates a sign of past fire damage;
 - B. The trees with slight damage have an excellent chance of recovering to their original form. Trees with moderate damage have a good chance of recovery with alterations in form. Heavy percentage of burn on trees will significantly alter their form and lower their probability of survival to half;
 - C. The "complete" category is for those trees that burned to the ground.
10. **Mainstem Dieback** - death of healthy mainstems from the growing tip back.
11. **Branch Cavities** - hollow areas in the trunk or limbs in the upper tree, usually due to the decay of wood.
12. **Weak Crotches** - poorly formed branch attachments.
13. **Twig/Branch Dieback** - death of unhealthy twigs from the growing tip back.
14. **Exocormic Growth** - excessive growth along main limbs, rather than on twigs.
15. **Thin Foliage** - defoliation and twig dieback throughout the canopy.
16. **Vigor** - is the capacity of a tree for growth and survival. Below are the ratings:
Good (G) - New tip growth; good leaf color; relatively smooth bark free from cracks/decay;
Moderate (M) - Some new tip growth; medium leaf color; some dead wood; thinning crown;
Poor (P) - No new tip growth; poor leaf color; abnormal bark; much dead wood; heavily thinned crown.
A vigorous tree will more easily ward off disease and/or insect attacks, and should recover from impacts more quickly than a weak tree.
17. **Terrain** - refers to the topography of the land where the tree is found.
18. **Potential Hazard** - any tree may be more or less a hazard to people depending on its location and/or health.

RATINGS

1. The **Health** of the trees was visually determined from a macroscopic inspection of signs and symptoms of disease. The following describes our system:
- A. **Outstanding** - A healthy and vigorous tree characteristic of its species and free of any visible signs of disease or pest infestation;
 - B. **Above Average** - A healthy and vigorous tree. However, there are minor visible signs of disease and pest infestation;
 - C. **Average** - Although healthy in overall appearance, there is a normal amount of disease and/or pest infestation;
 - D. **Below Average/Poor*** - This tree is characterized by exhibiting a greater degree of disease and/or pest infestation or structural instability than normal and appears to be in a state of decline. This tree also exhibits extensive signs of dieback;
 - E. **Dead*** - This tree exhibits no signs of life whatsoever at the time of field evaluation.
*A tree rating of "D" and lower is in a low stage of vigor and naturally a meaningful level of recovery is doubtful. Removal should be considered if it is within the proposed project development.
2. The **Aesthetic/Conformity** quality of the trees was visually determined from an overall inspection of appearance. The following describes our system:
- A. **Outstanding** - The tree is visually symmetrical, having the ideal form & appearance for the species;
 - B. **Average** - The tree, though non-symmetrical, has an appealing form for the species with very little dieback of foliage or twigs/branches;
 - C. **Below Average** - The tree is non-symmetrical for the species with an unappealing form and/or has much dieback of foliage and twigs/branches;

DEFINITIONS

General Trees

Page 3 of 3

- D. **Poor** - The tree has few positive characteristics and may detract from the beauty of the landscape.

TREATMENT

1. **Remove Dead Wood** - if noticeable dead wood in the canopy makes tree unattractive, it can be removed.
2. **Remove Wire, etc.** - if anything has been physically attached to the tree, it should be removed.
3. **Insect/Disease Treatment** - see TREE PRESERVATION PROGRAM within this report for explanation.
4. **Cable/Brace** - can extend the time the tree remains healthy, attractive and hazard free.
5. **None** - no treatment is recommended.
6. **Remove Tree** - if the tree can't be saved through any type of treatment, it should be removed.

REMARKS (Some other terms that may be used)

1. **Basal Growth** - is leaf growth generating from around base of trunk.
2. **Exposed Buttress Roots** - when soil is absent at the base of the tree.
3. **Heart Rot** - is decomposition of heartwood (the central portion of a twig/branch/trunk).
4. **Powdery Mildew** - are leaves that are covered by a white powdery growth generally when new growth becomes wet for long periods of time; leaves may be distorted, stunted and drop prematurely.
5. **Cankers** - are rough swellings with depressed centers resulting in death of tissue that later cracks open and exposes the wood underneath in twigs, branches, and/or trunks.
6. **Chlorotic Leaves** - leaf veins remain normally green, but the tissue between veins becomes yellow, which is usually caused by nutrient deficiencies.
7. **Mottling** - are leaves that have a variegated pattern of green and yellow.
8. **Defoliation** - is a premature leaf drop.
9. **Bark Beetle Frass** - are wood fragments mixed in the insect's excrement.
10. **Witches Broom** - is an abnormal growth cluster of twigs that may be caused by pruning, insects, mites, fungus, etc.
11. **Mistletoe** - is a leafy evergreen perennial parasite with dark green leathery leaves.
12. **Crowded** - is a tree within the canopy of an adjacent tree or canopy.
13. **Shading Out** - is the defoliation and twig dieback inside the canopy due to the lack of sunlight.

OAK TREE LOCATION MAP

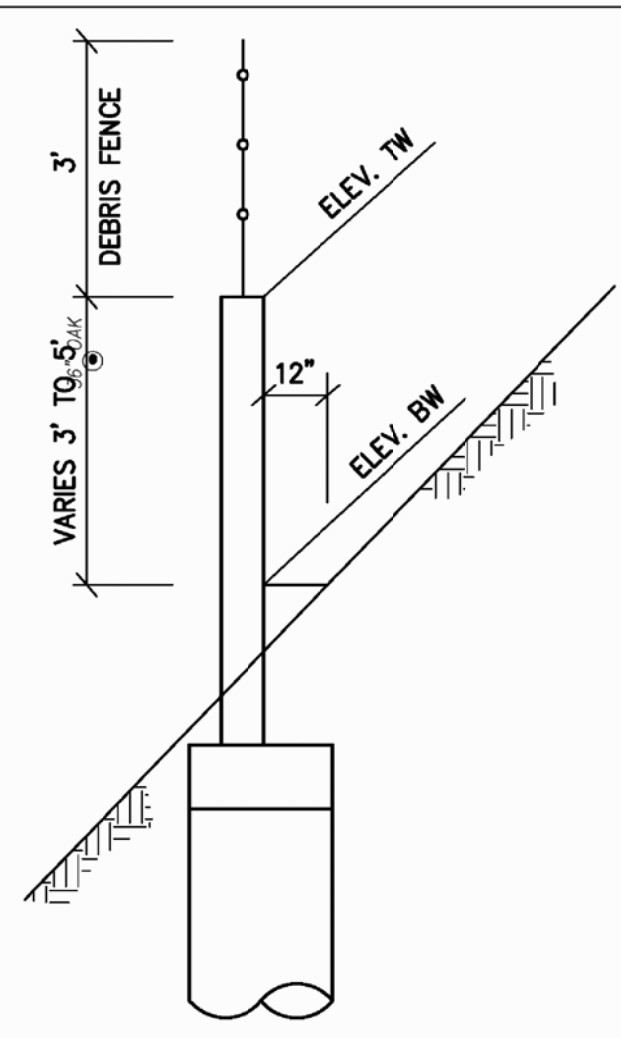
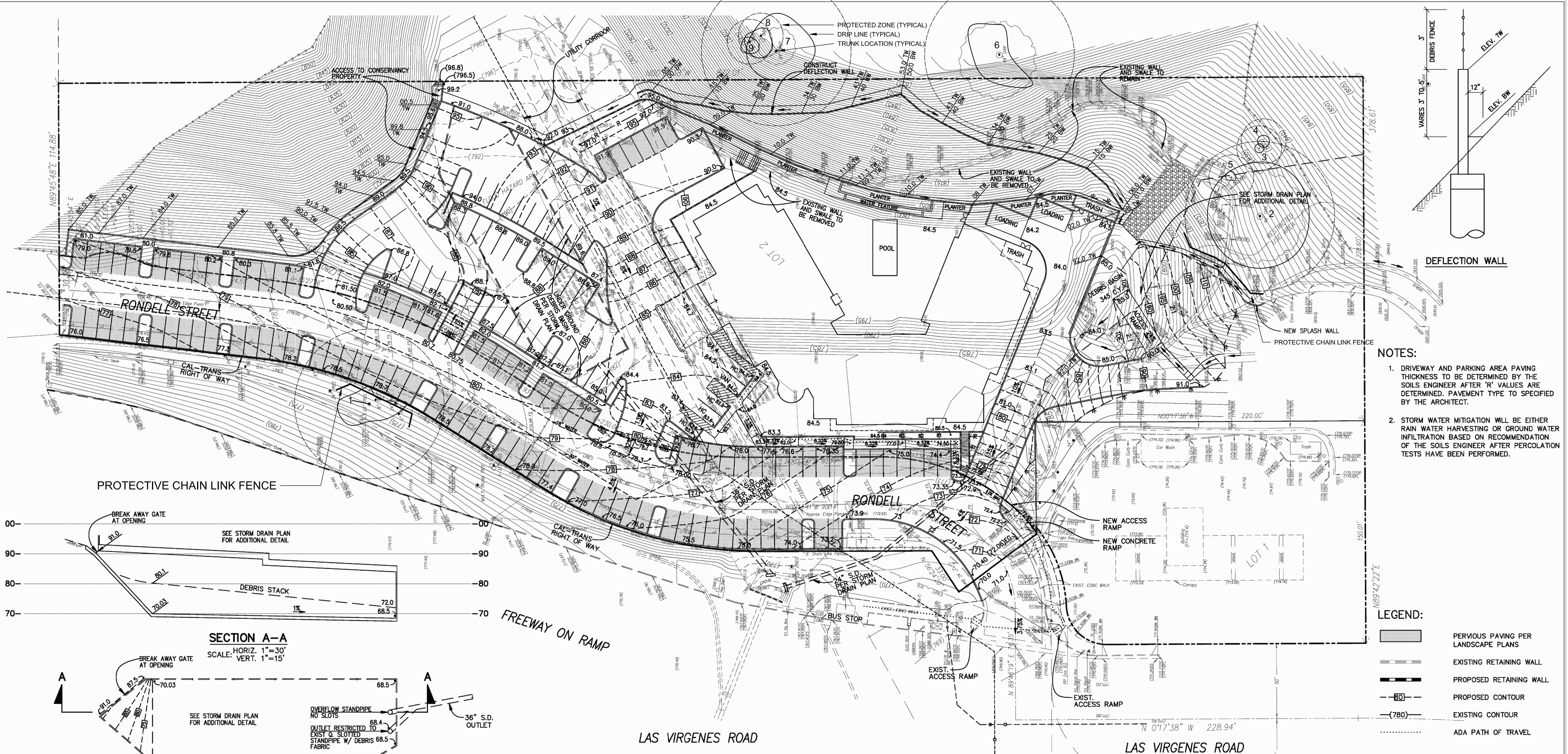

- NOTES:**
- DRIVEWAY AND PARKING AREA PAVING THICKNESS TO BE DETERMINED BY THE SOILS ENGINEER AFTER 'R' VALUES ARE DETERMINED. PAVEMENT TYPE TO SPECIFIED BY THE ARCHITECT.
 - STORM WATER MITIGATION WILL BE EITHER RAIN WATER HARVESTING OR GROUND WATER INFILTRATION BASED ON RECOMMENDATION OF THE SOILS ENGINEER AFTER PERCOLATION TESTS HAVE BEEN PERFORMED.

- LEGEND:**
- PERVIOUS PAVING PER LANDSCAPE PLANS
 - EXISTING RETAINING WALL
 - PROPOSED RETAINING WALL
 - PROPOSED CONTOUR
 - EXISTING CONTOUR
 - ADA PATH OF TRAVEL

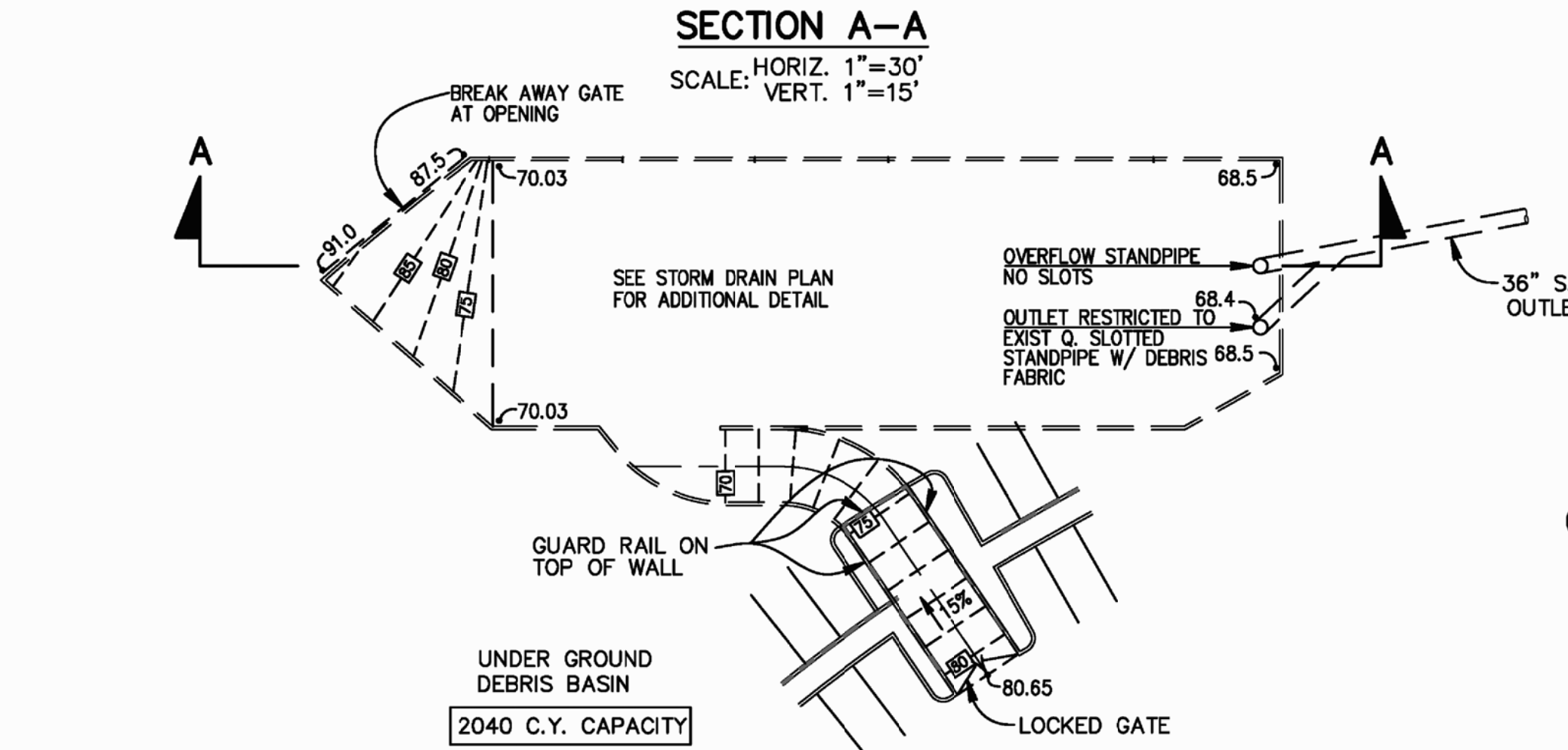
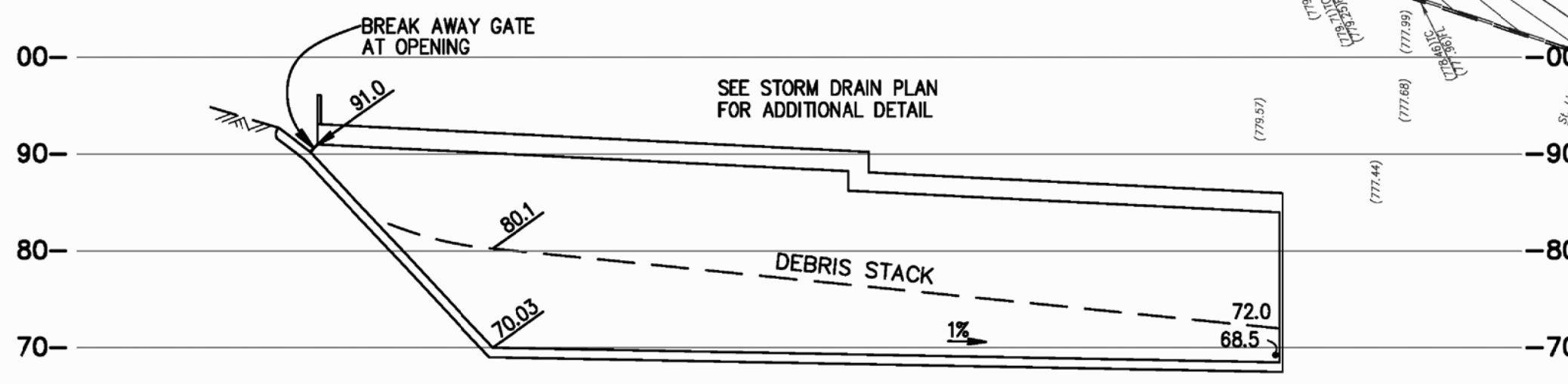

GRADING SUMMARY
 CUT= 24,416 C.Y.
 FILL= 3,403 C.Y.
 EXPORT= 21,013 C.Y.

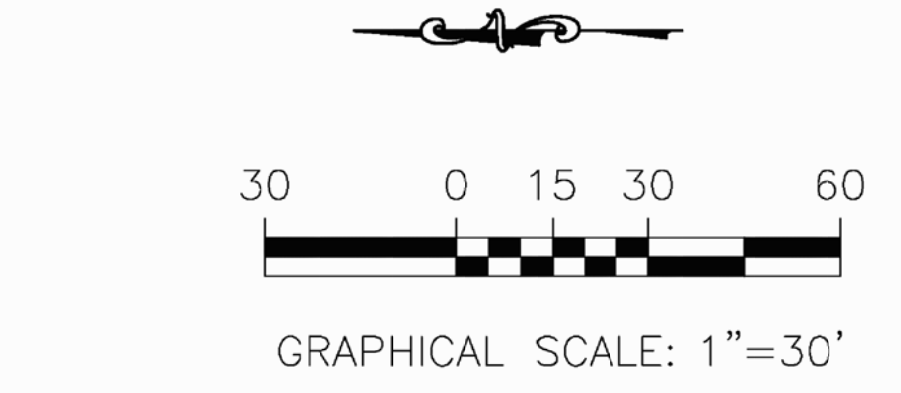

APPROVED FOR CONSTRUCTION:
 ROBERT YALDA, P.E.
 CITY ENGINEER/PUBLIC WORKS DIRECTOR
 DATE _____

REVISIONS				
No.	DESCRIPTION	REVISED BY:	APPROVED BY:	DATE

RECORD DRAWING

I HEREBY CERTIFY THAT THE WORK SHOWN ON DRAWING No. _____ SHEET No. _____ THROUGH _____, MARKED AS "RECORD DRAWING", HAS BEEN CONSTRUCTED IN CONFORMANCE WITH LINES AND GRADES AS SHOWN ON SAID PLANS, DRAWINGS, REFERENCED SPECIFICATIONS, AND APPROVED CHANGE ORDERS, AS INDICATED IN THE REVISION BLOCK.

SIGNATURE _____ DATE _____
 NAME _____ INSPECTOR _____

AS-BUILT DRAWING

I HEREBY CERTIFY THAT THE WORK SHOWN HEREON, MARKED AS "AS-BUILT", HAS BEEN CONSTRUCTED IN CONFORMANCE WITH LINES AND GRADES AS SHOWN ON SAID PLANS, DRAWINGS, REFERENCED SPECIFICATIONS, AND APPROVED CHANGE ORDERS, AS INDICATED IN THE REVISION BLOCK.

PROJECT ENGINEER'S SIGNATURE _____ DATE _____
 PROJECT ENGINEER'S NAME _____ CITY LAND DEVELOPMENT REP. _____

GRADING PLAN

26300 RONDELL STREET
 TRACK NUMBER / PARCEL NUMBER

DESIGNED BY: _____
 CHECKED BY: _____
 DRAWN BY: _____
 SCALE: 1"=30"
 SHEET NO. 3 of 5

PREPARED FOR:
 RONDELL OASIS, LLC
 P.O. BOX 6528
 MALIBU, CA 90264

APRIL 7, 2015
 REV. JUNE 8, 2015
 JOB # 200-545

L. Newman Design Group, Inc.

CITY OF CALABASAS PUBLIC WORKS DEPARTMENT
 100 CIVIC CENTER WAY
 CALABASAS, CA 91302
 PHONE 818.224.1600
 FAX 818.223.7339
 WWW.CITYOFCALABASAS.COM

Appendix B

Sight Line Study



NADEL RESIDENTIAL & COMMERCIAL, INC
 1990 S. BUNDY DRIVE
 SUITE 400
 LOS ANGELES, CA 90025
 T. 310.825.2100
 F. 310.825.0182
WWW.NADELARC.COM
 LOS ANGELES
 COSTA MESA
 SAN DIEGO
 LAS VEGAS



PROFESSIONAL STAMPS:
 CONSULTANT:

CLIENT:
RONDELL OASIS, LLC

P.O. BOX 6528
 MALIBU, CA 90264

PROJECT:
RONDELL OASIS HOTEL

PROJECT ADDRESS:
 29300 RONDELL STREET
 CALIFORNIA

PUBLIC AGENCY SUBMITTAL:	N/A
ISSUED FOR BIDDING:	N/A
ISSUED FOR CONSTRUCTION:	N/A
REVISIONS:	
ISSUE NO.:	ISSUE DATE:

NADEL PROJECT NO.:	1326
PROJECT DATE:	04.22.2015
ISSUES:	
DRAWING TITLE:	

CONCEPTUAL SET

SITE LINE STUDY
 SITE PLAN

A1.01A

PLOT DATE: Apr 22, 2015 - 2:04pm

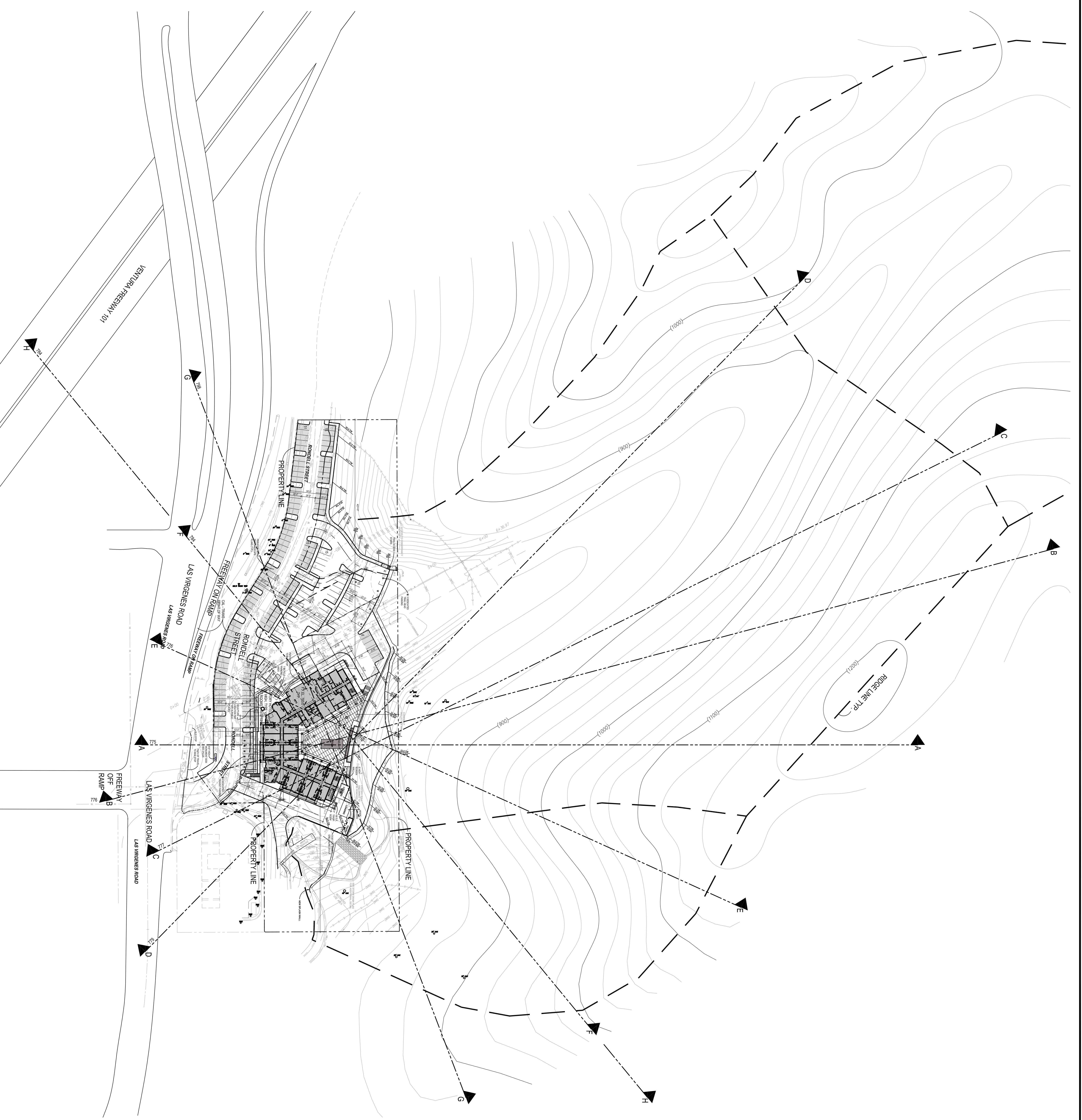

NOTE:
 FOR SECTION A-A AND B-B SEE A10.01B
 FOR SECTION C-C AND D-D SEE A10.01C
 FOR SECTION E-E AND F-F SEE A10.01D
 FOR SECTION G-G AND H-H SEE A10.01E

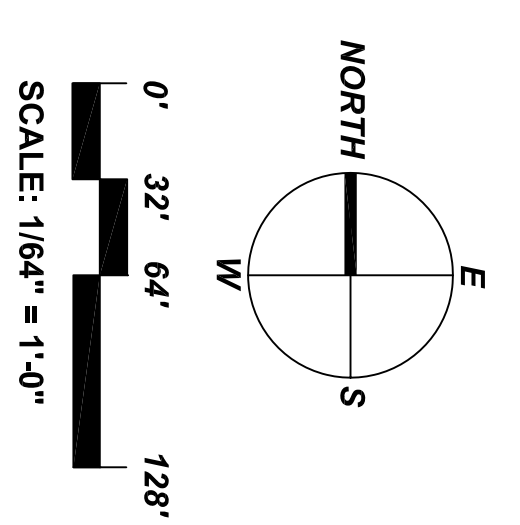

SITE LINE STUDY SITE PLAN

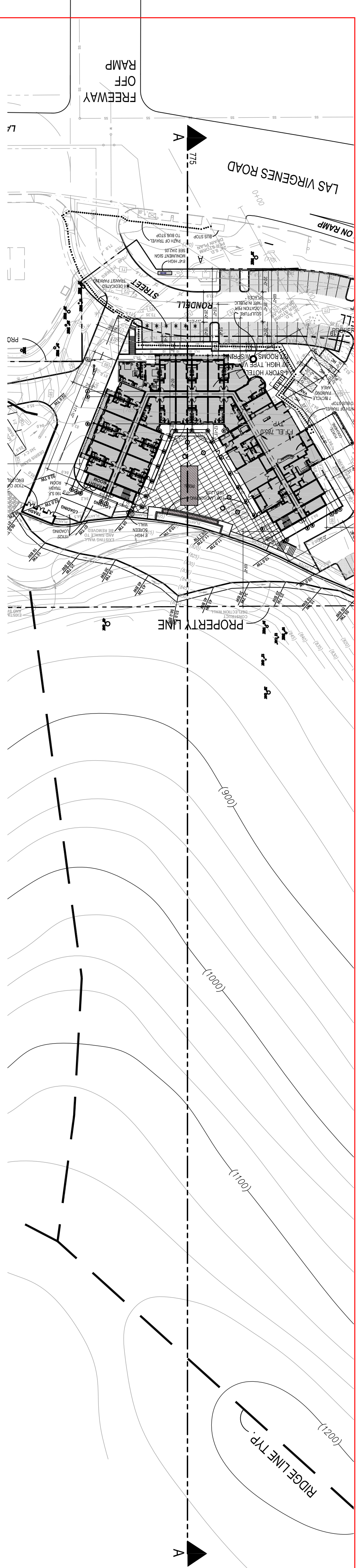

SITE LINE PLAN FOR SECTION A-A

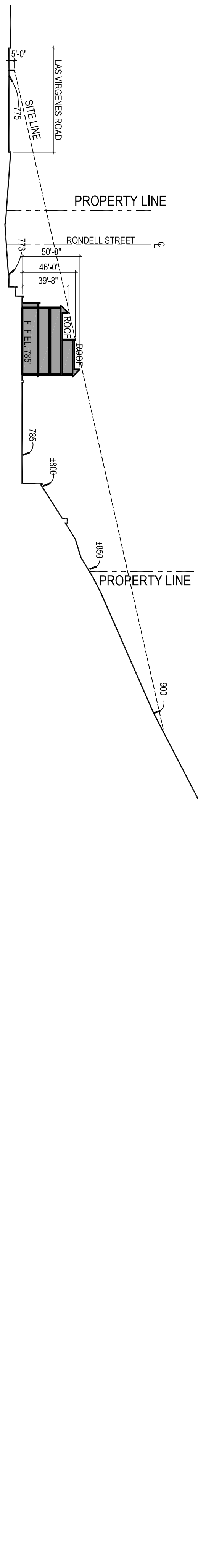

SECTION A-A

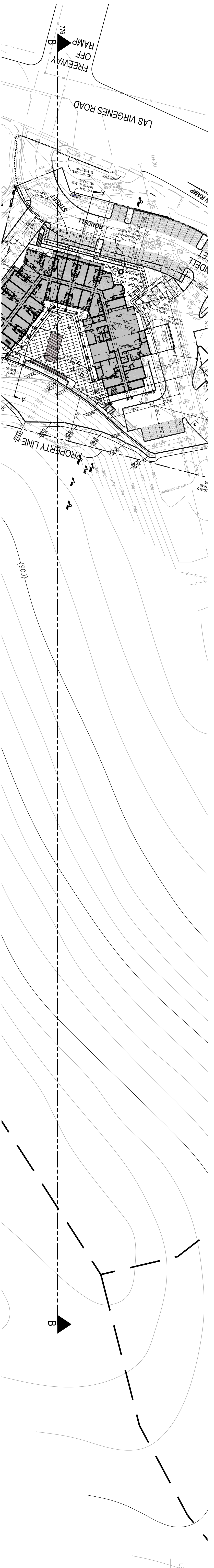
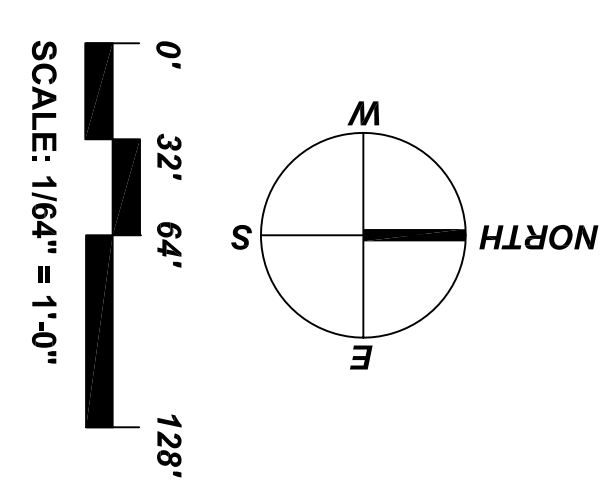

SITE LINE PLAN FOR SECTION B-B

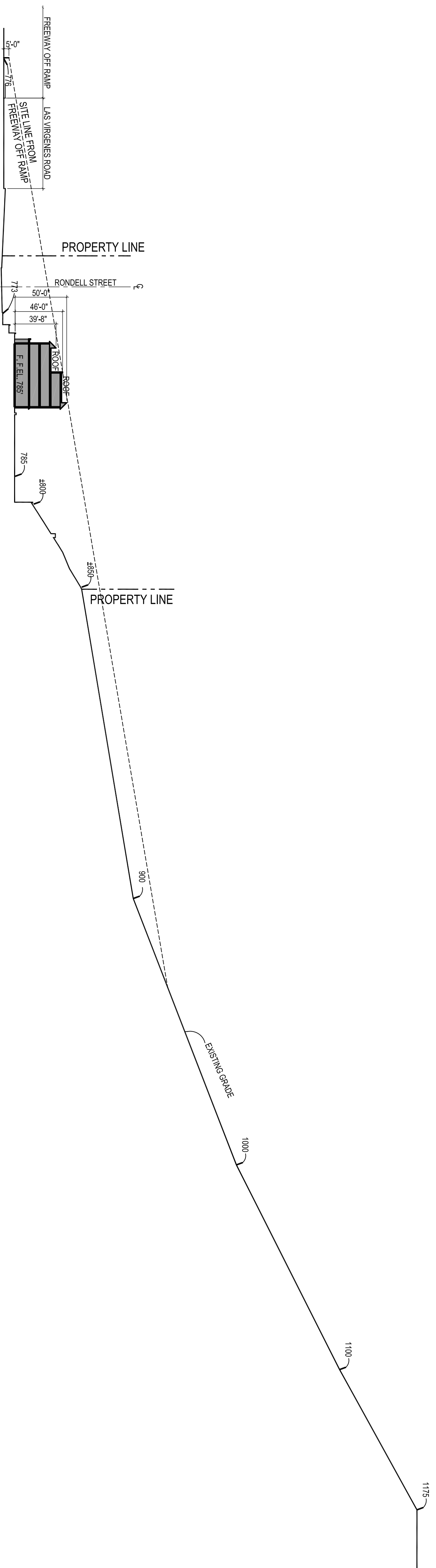

SECTION B-B

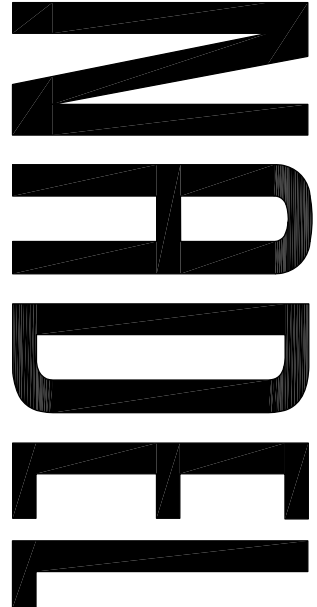
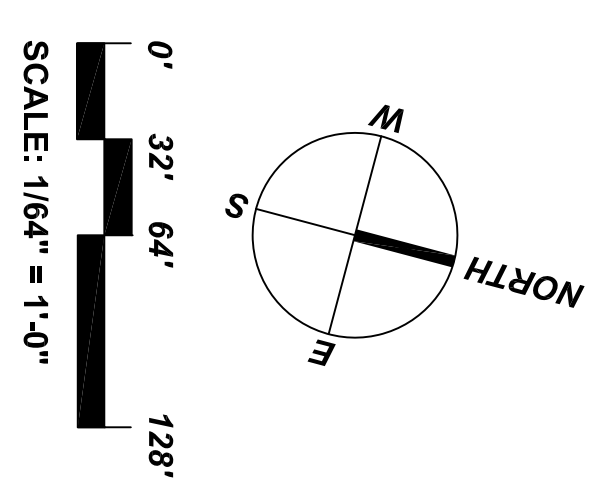

NADEL RESIDENTIAL & COMMERCIAL, INC
 1990 S. BUNDY DRIVE
 SUITE 400
 LOS ANGELES, CA 90025
 T. 310.825.2100
 F. 310.825.0182
WWW.NADELARC.COM
 LOS ANGELES
 COSTA MESA
 SAN DIEGO
 LAS VEGAS



CONSULTANT:

CLIENT:
RONDELL OASIS, LLC

P.O. BOX 6528
 MALIBU, CA 90264

PROJECT:
RONDELL OASIS HOTEL

PROJECT ADDRESS:
 29300 RONDELL STREET
 CALIFORNIA, CALIFORNIA

PUBLIC AGENCY SUBMITTAL:	N/A
ISSUED FOR BIDDING:	N/A
ISSUED FOR CONSTRUCTION:	N/A
REVISIONS:	
ISSUE DESCRIPTION:	ISSUE DATE:
NO.:	DATE:

MODEL PROJECT No.:	13256
PROJECT DATE:	04/22/2015
ISSUE DATE:	
DRAWING TITLE:	

CONCEPTUAL SET

SITE LINE STUDY
 SECTION A-A
 AND SECTION B-B

A1.01B

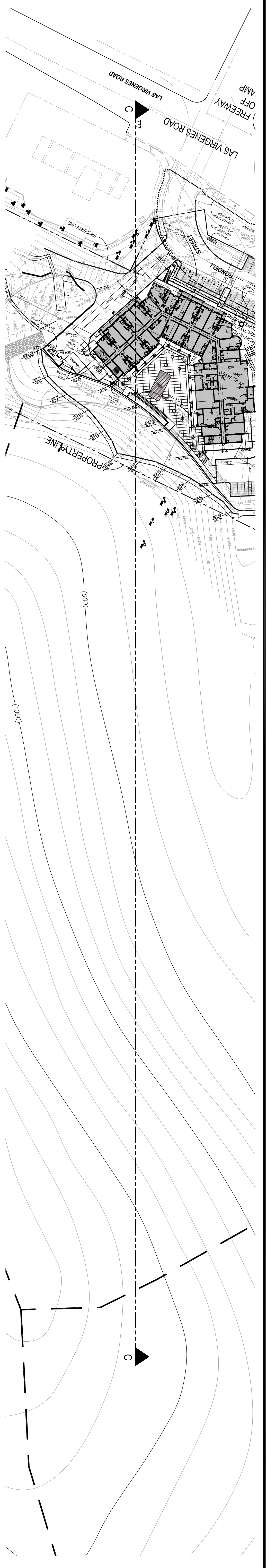

SITE LINE PLAN FOR SECTION C-C

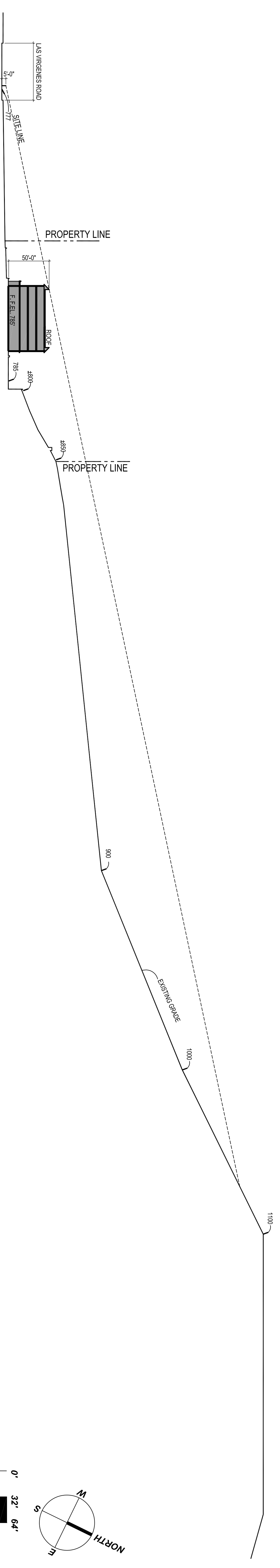

SECTION C-C

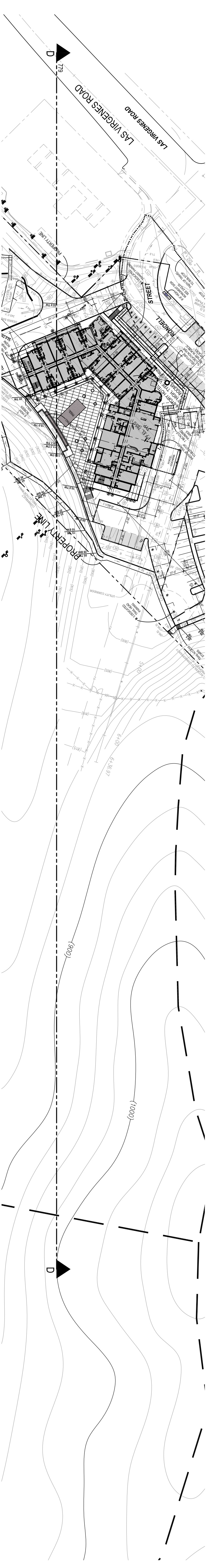

SITE LINE PLAN FOR SECTION D-D

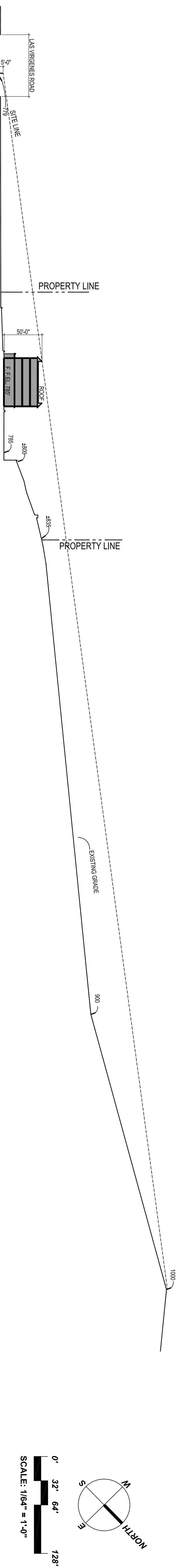

SECTION D-D

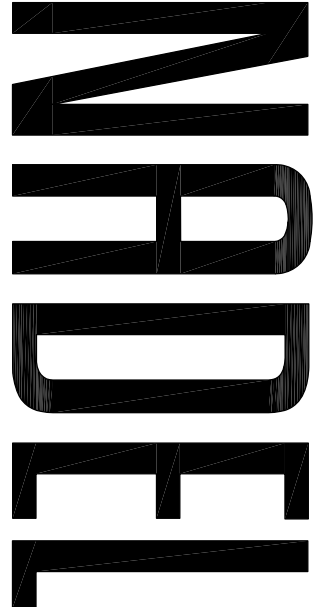

NADEL RESIDENTIAL & COMMERCIAL, INC
 1990 S. BUNDY DRIVE
 SUITE 400
 LOS ANGELES, CA 90025
 T. 310.825.2100
 F. 310.825.0182
WWW.NADELARC.COM
 LOS ANGELES
 COSTA MESA
 SAN DIEGO
 LAS VEGAS



CONSULTANT:

CLIENT:
RONDELL OASIS, LLC

P.O. BOX 6528
 MALIBU, CA 90264

PROJECT:
RONDELL OASIS HOTEL

PROJECT ADDRESS:
 29300 RONDELL STREET
 CALIFORNIA

PUBLIC AGENCY SUBMITTAL:	N/A
ISSUED FOR BIDDING:	N/A
ISSUED FOR CONSTRUCTION:	N/A
REVISIONS:	
ISSUE NO.:	ISSUE DATE:
ISSUE DESCRIPTION:	

MODEL PROJECT NO.:	1326
PROJECT DATE:	04.22.2015
ISSUE NO.:	ISSUE DATE:
DRAWING TITLE:	

CONCEPTUAL SET

A1.01C



SITE LINE PLAN FOR SECTION E-E

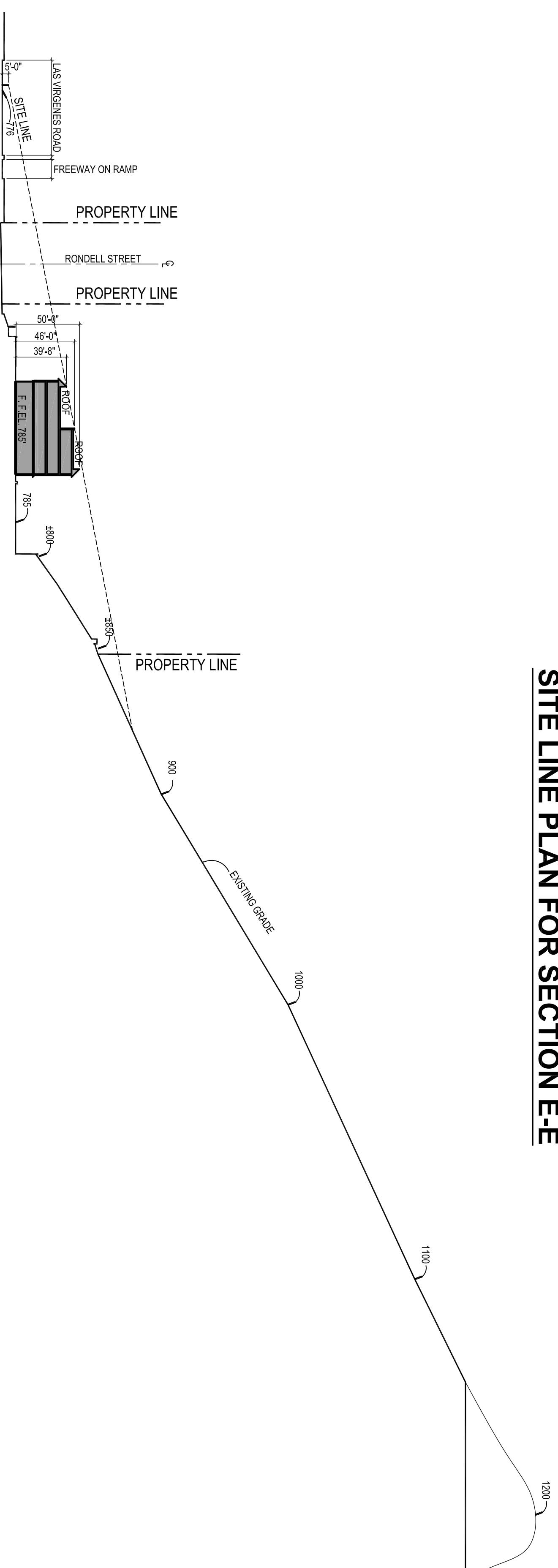

SECTION E-E

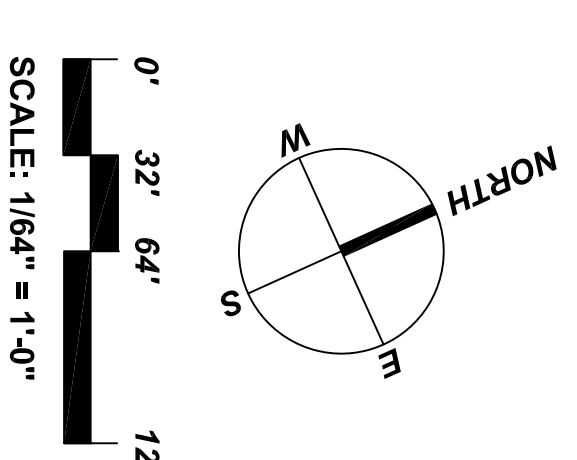

SITE LINE PLAN FOR SECTION F-F

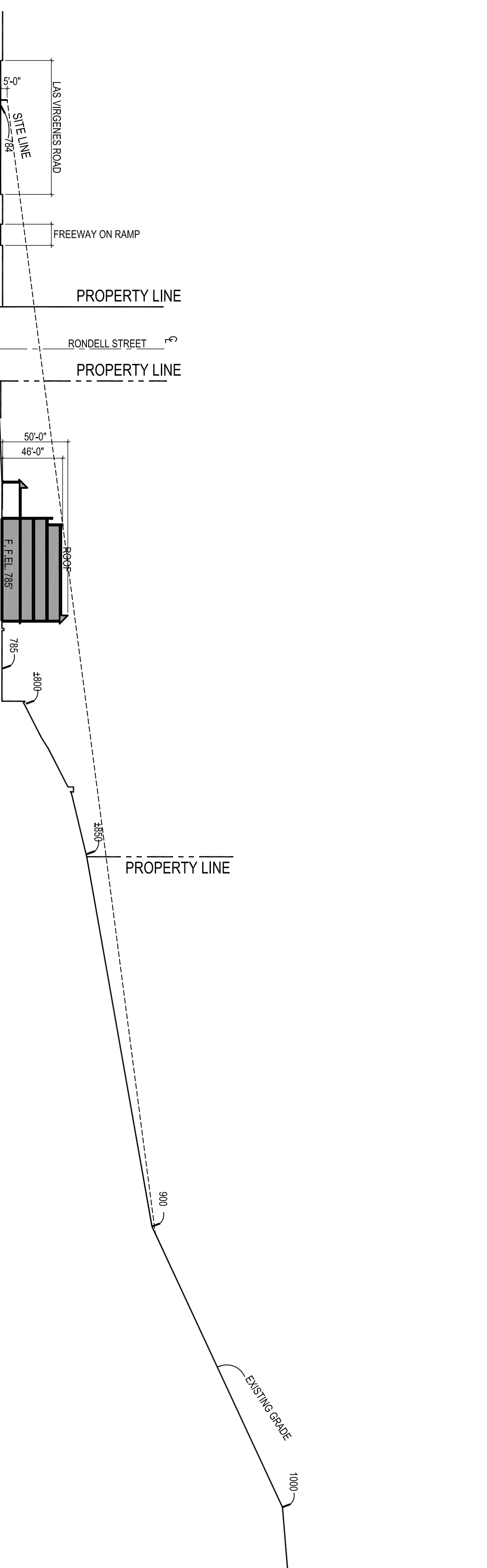

SECTION F-F

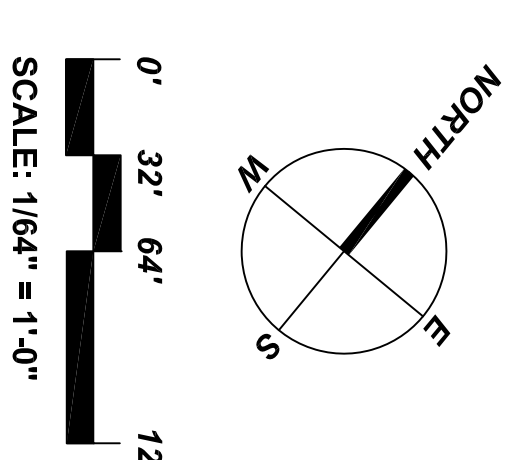

NADEL

NADEL RESIDENTIAL & COMMERCIAL, INC
 1990 S. BUNDY DRIVE
 SUITE 400
 LOS ANGELES, CA 90025
 T. 310.825.2100
 F. 310.825.0182
 WWW.NADELARC.COM
 LOS ANGELES
 COSTA MESA
 SAN DIEGO
 LAS VEGAS

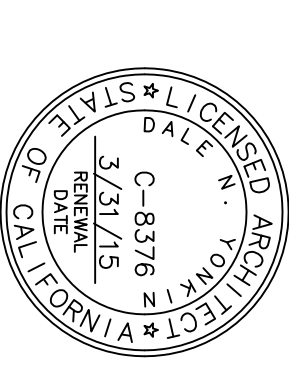

CONSULTANT:

CLIENT:
RONDELL OASIS, LLC

P.O. BOX 6528
 MALIBU, CA 90264

PROJECT:
RONDELL OASIS HOTEL

PROJECT ADDRESS:
 29300 RONDELL STREET
 CALIFORNIA

PUBLIC AGENCY SUBMITTAL:	N/A
ISSUED FOR BIDDING:	N/A
ISSUED FOR CONSTRUCTION:	N/A
REVISIONS:	
ISSUE NO.:	
ISSUE DESCRIPTION:	
ISSUE DATE:	

MODEL PROJECT NO.:	13256
PROJECT DATE:	04.22.2015
DRAWING TITLE:	ISSUE

CONCEPTUAL SET

SITE LINE STUDY
 SECTION E-E
 AND SECTION F-F

A1.01D

PLOT DATE: Apr 22, 2015 - 2:13pm

ALL DIMENSIONS AND VERTICALS ARE APPROXIMATE. THE ORIGINAL AND UNPUBLISHED WORK OF THE ARCHITECT AND THE SAME MAY NOT BE REPRODUCED, USED OR DISCLOSED WITHOUT THE WRITTEN CONSENT OF THE ARCHITECT. COPYRIGHT © 2015, NADEL RESIDENTIAL & COMMERCIAL, INC. ALL RIGHTS RESERVED.



SITE LINE PLAN FOR SECTION G-G

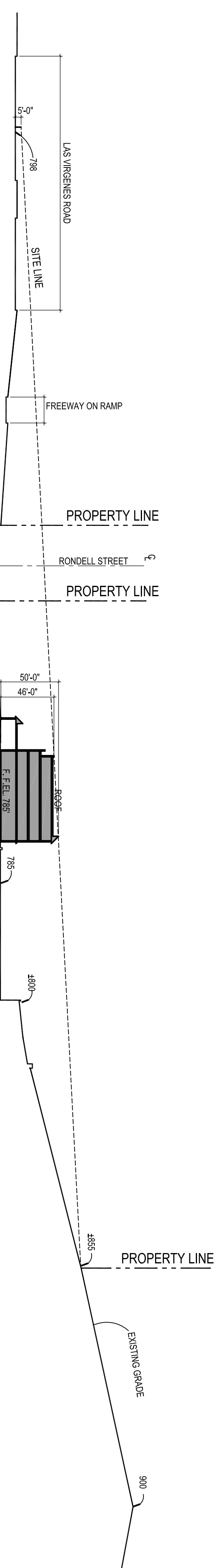

SECTION G-G

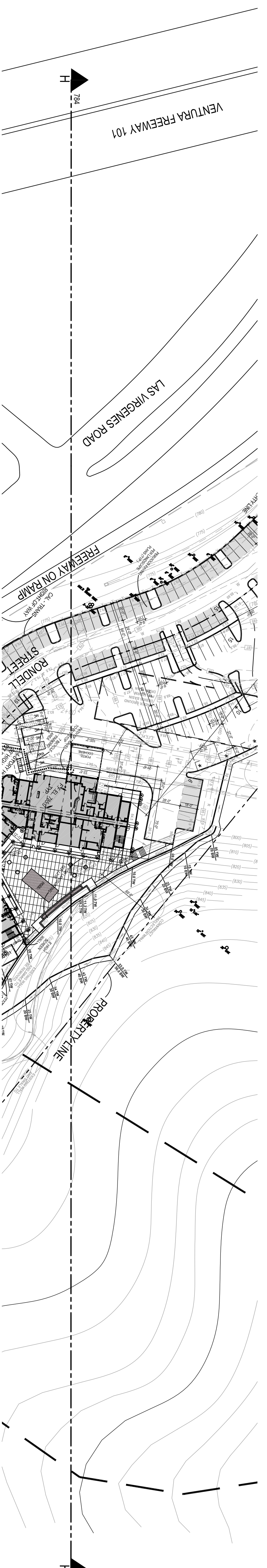
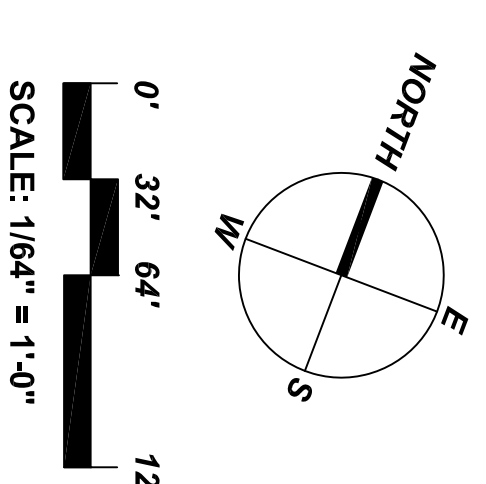

SITE LINE PLAN FOR SECTION H-H

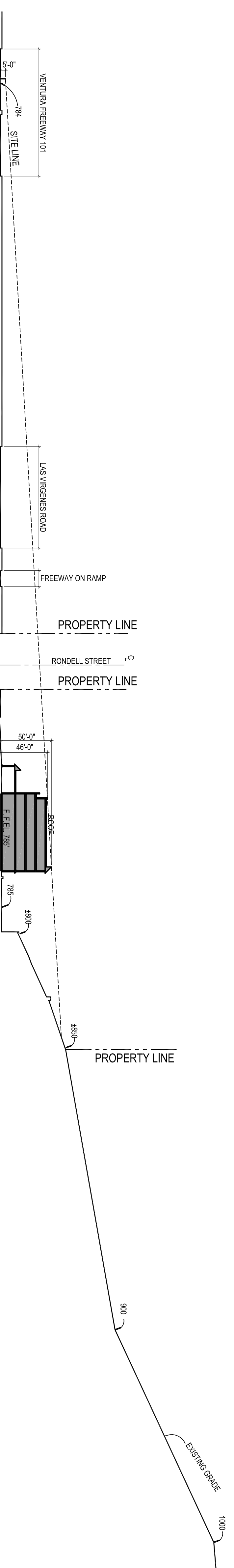

SECTION H-H

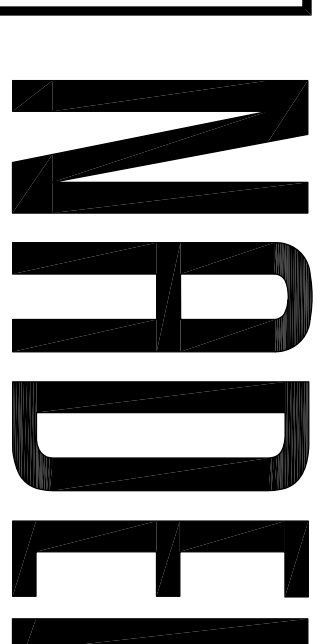
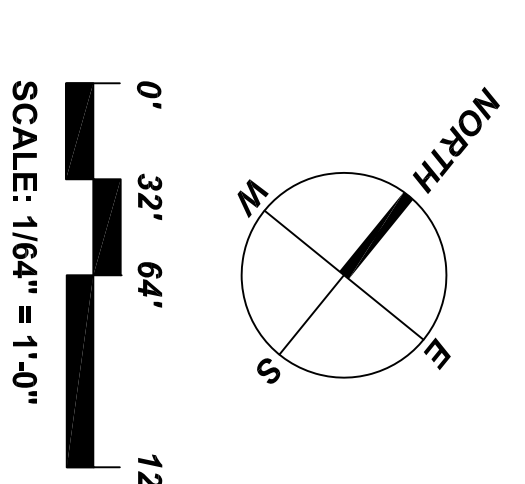

NADEL RESIDENTIAL & COMMERCIAL, INC
 1990 S. BUNDY DRIVE SUITE 400
 LOS ANGELES, CA 90025
 T. 310.825.2100 F. 310.825.0182
WWW.NADELARC.COM
 LOS ANGELES COSTA MESA SAN DIEGO LAS VEGAS

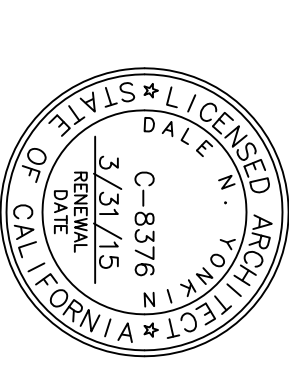

CONSULTANT:

CLIENT:
RONDELL OASIS, LLC

P.O. BOX 6528
 MALIBU, CA 90264

PROJECT:
RONDELL OASIS HOTEL

PROJECT ADDRESS:
 29300 RONDELL STREET
 CALIFORNIA CALIFORNIA

PUBLIC AGENCY SUBMITTAL:	N/A
ISSUED FOR BIDDING:	N/A
ISSUED FOR CONSTRUCTION:	N/A
REVISIONS:	
ISSUE NO.:	
ISSUE DESCRIPTION:	
ISSUE DATE:	

MODEL PROJECT No.: 13256
 PROJECT DATE: 04.22.2015
 DRAWING TITLE:

CONCEPTUAL SET

SITE LINE STUDY
 SECTION G-G
 AND SECTION H-H

A1.01DE

PLOT DATE: Apr 22, 2015 - 2:16pm

ALL DIMENSIONS AND VERTICAL CURVES APPEARING HEREIN CONSTITUTE THE ORIGINAL AND UNPUBLISHED WORK OF THE ARCHITECT AND THE SAME MAY NOT BE REPRODUCED, USED OR PUBLISHED WITHOUT THE WRITTEN CONSENT OF THE ARCHITECT. COPYRIGHT © 2015 NADEL RESIDENTIAL & COMMERCIAL, INC. ALL RIGHTS RESERVED.

Appendix C

Air Quality Model Results



Rondell Oasis Hotel Project

South Coast AQMD Air District, Annual

1.0 Project Characteristics

1.1 Land Usage

Land Uses	Size	Metric	Lot Acreage	Floor Surface Area	Population
Parking Lot	151.00	Space	1.36	60,400.00	0
Hotel	127.00	Room	3.64	72,954.00	0

1.2 Other Project Characteristics

Urbanization	Urban	Wind Speed (m/s)	2.2	Precipitation Freq (Days)	31
Climate Zone	9			Operational Year	2018
Utility Company	Southern California Edison				
CO2 Intensity (lb/MWhr)	630.89	CH4 Intensity (lb/MWhr)	0.029	N2O Intensity (lb/MWhr)	0.006

1.3 User Entered Comments & Non-Default Data

Project Characteristics - Operational year would be 2017, however, for the purposes of CalEEMod, the operational year input must be a year after all construction ends.

Land Use - Square feet of total building area from Nadel Residential & Commercial Inc., Site Plan, 2/13/2015. Project site approximately 5 acres.

Construction Phase - Applicant provided construction schedule.

Grading - Export from applicant provided grading quantities. Construction would occur on approximately 3.5 acres of the project site.

Architectural Coating - Use of low-VOC paint (150 g/L for nonflat coatings) as required by SCAQMD Rule 1113.

Vehicle Trips - Default vehicle trip rates consistent with Traffic Impact Analysis prepared by Overland Traffic Consultants, Inc. (December 2014).

Woodstoves - Project does not include woodstoves or wood burning fireplaces.

Area Coating - Use of low-VOC paint (150 g/L for nonflat coatings) as required by SCAQMD Rule 1113.

Energy Use -

Construction Off-road Equipment Mitigation - Compliance with SCAQMD Fugitive Dust Rule 403. Assumes that equipment used would comply with current EPA and ARB Tier 3 standards for nonroad diesel engines.

Area Mitigation - Use of low-VOC paint (150 g/L for nonflat coatings) as required by SCAQMD Rule 1113. Project would include at most one natural gas hearth and no wood burning hearths or woodstoves.

Trips and VMT -

Table Name	Column Name	Default Value	New Value
tblArchitecturalCoating	EF_Nonresidential_Exterior	250.00	150.00
tblArchitecturalCoating	EF_Nonresidential_Interior	250.00	150.00
tblAreaCoating	Area_EF_Nonresidential_Exterior	250	150
tblAreaMitigation	UseLowVOCPaintNonresidentialInteriorValue	250	150
tblConstEquipMitigation	NumberOfEquipmentMitigated	0.00	1.00
tblConstEquipMitigation	NumberOfEquipmentMitigated	0.00	1.00
tblConstEquipMitigation	NumberOfEquipmentMitigated	0.00	1.00
tblConstEquipMitigation	NumberOfEquipmentMitigated	0.00	3.00
tblConstEquipMitigation	NumberOfEquipmentMitigated	0.00	1.00
tblConstEquipMitigation	NumberOfEquipmentMitigated	0.00	1.00
tblConstEquipMitigation	NumberOfEquipmentMitigated	0.00	2.00
tblConstEquipMitigation	NumberOfEquipmentMitigated	0.00	2.00
tblConstEquipMitigation	NumberOfEquipmentMitigated	0.00	2.00

tblConstEquipMitigation	NumberOfEquipmentMitigated	0.00	4.00
tblConstEquipMitigation	NumberOfEquipmentMitigated	0.00	10.00
tblConstEquipMitigation	NumberOfEquipmentMitigated	0.00	1.00
tblConstEquipMitigation	Tier	No Change	Tier 3
tblConstEquipMitigation	Tier	No Change	Tier 3
tblConstEquipMitigation	Tier	No Change	Tier 3
tblConstEquipMitigation	Tier	No Change	Tier 3
tblConstEquipMitigation	Tier	No Change	Tier 3
tblConstEquipMitigation	Tier	No Change	Tier 3
tblConstEquipMitigation	Tier	No Change	Tier 3
tblConstEquipMitigation	Tier	No Change	Tier 3
tblConstEquipMitigation	Tier	No Change	Tier 3
tblConstEquipMitigation	Tier	No Change	Tier 3
tblConstEquipMitigation	Tier	No Change	Tier 3
tblConstEquipMitigation	Tier	No Change	Tier 3
tblConstructionPhase	NumDays	18.00	101.00
tblConstructionPhase	NumDays	230.00	240.00
tblConstructionPhase	NumDays	8.00	99.00
tblConstructionPhase	NumDays	18.00	21.00
tblConstructionPhase	NumDays	5.00	42.00
tblConstructionPhase	PhaseEndDate	12/1/2016	2/13/2017
tblConstructionPhase	PhaseEndDate	8/15/2017	5/8/2017
tblConstructionPhase	PhaseEndDate	10/21/2016	9/13/2016
tblConstructionPhase	PhaseEndDate	3/14/2017	3/9/2017
tblConstructionPhase	PhaseEndDate	6/12/2017	7/13/2016
tblConstructionPhase	PhaseStartDate	7/14/2016	9/26/2016
tblConstructionPhase	PhaseStartDate	9/14/2016	6/7/2016
tblConstructionPhase	PhaseStartDate	6/7/2016	4/28/2016

tblConstructionPhase	PhaseStartDate	2/14/2017	2/9/2017
tblConstructionPhase	PhaseStartDate	5/9/2017	6/9/2016
tblGrading	AcresOfGrading	49.50	3.50
tblGrading	MaterialExported	0.00	13,820.00
tblLandUse	LandUseSquareFeet	184,404.00	72,954.00
tblLandUse	LotAcreage	4.23	3.64
tblProjectCharacteristics	OperationalYear	2014	2018

2.0 Emissions Summary

2.2 Overall Operational**Unmitigated Operational**

	ROG	NOx	CO	SO2	Fugitive PM10	Exhaust PM10	PM10 Total	Fugitive PM2.5	Exhaust PM2.5	PM2.5 Total	Bio- CO2	NBio- CO2	Total CO2	CH4	N2O	CO2e
Category	tons/yr										MT/yr					
Area	0.5602	3.0000e-005	3.6000e-003	0.0000		1.0000e-005	1.0000e-005		1.0000e-005	1.0000e-005	0.0000	6.9000e-003	6.9000e-003	2.0000e-005	0.0000	7.3000e-003
Energy	9.8400e-003	0.0895	0.0752	5.4000e-004		6.8000e-003	6.8000e-003		6.8000e-003	6.8000e-003	0.0000	290.0705	290.0705	0.0107	3.6200e-003	291.4172
Mobile	0.5255	1.3877	5.4538	0.0134	0.9023	0.0193	0.9216	0.2415	0.0178	0.2593	0.0000	1,002.5180	1,002.5180	0.0385	0.0000	1,003.3264
Waste						0.0000	0.0000		0.0000	0.0000	14.1140	0.0000	14.1140	0.8341	0.0000	31.6303
Water						0.0000	0.0000		0.0000	0.0000	1.0221	13.1422	14.1643	0.1056	2.6000e-003	17.1886
Total	1.0955	1.4772	5.5325	0.0139	0.9023	0.0262	0.9284	0.2415	0.0246	0.2661	15.1360	1,305.7375	1,320.8736	0.9889	6.2200e-003	1,343.5699

2.2 Overall Operational

Mitigated Operational

	ROG	NOx	CO	SO2	Fugitive PM10	Exhaust PM10	PM10 Total	Fugitive PM2.5	Exhaust PM2.5	PM2.5 Total	Bio- CO2	NBio- CO2	Total CO2	CH4	N2O	CO2e
Category	tons/yr										MT/yr					
Area	0.5342	3.0000e-005	3.6000e-003	0.0000		1.0000e-005	1.0000e-005		1.0000e-005	1.0000e-005	0.0000	6.9000e-003	6.9000e-003	2.0000e-005	0.0000	7.3000e-003
Energy	9.8400e-003	0.0895	0.0752	5.4000e-004		6.8000e-003	6.8000e-003		6.8000e-003	6.8000e-003	0.0000	290.0705	290.0705	0.0107	3.6200e-003	291.4172
Mobile	0.5255	1.3877	5.4538	0.0134	0.9023	0.0193	0.9216	0.2415	0.0178	0.2593	0.0000	1,002.5180	1,002.5180	0.0385	0.0000	1,003.3264
Waste						0.0000	0.0000		0.0000	0.0000	14.1140	0.0000	14.1140	0.8341	0.0000	31.6303
Water						0.0000	0.0000		0.0000	0.0000	1.0221	13.1422	14.1643	0.1056	2.6000e-003	17.1870
Total	1.0695	1.4772	5.5325	0.0139	0.9023	0.0262	0.9284	0.2415	0.0246	0.2661	15.1360	1,305.7375	1,320.8736	0.9889	6.2200e-003	1,343.5682

	ROG	NOx	CO	SO2	Fugitive PM10	Exhaust PM10	PM10 Total	Fugitive PM2.5	Exhaust PM2.5	PM2.5 Total	Bio- CO2	NBio-CO2	Total CO2	CH4	N2O	CO2e
Percent Reduction	2.37	0.00	0.00	0.00	0.00	0.00	0.00	0.00	0.00	0.00	0.00	0.00	0.00	0.00	0.00	0.00

3.0 Construction Detail

Construction Phase

Phase Number	Phase Name	Phase Type	Start Date	End Date	Num Days Week	Num Days	Phase Description
1	Site Preparation	Site Preparation	4/8/2016	6/6/2016	5	42	
2	Grading	Grading	4/28/2016	9/13/2016	5	99	
3	Building Construction	Building Construction	6/7/2016	5/8/2017	5	240	
4	Trenching and Utilities	Trenching	6/9/2016	7/13/2016	5	25	
5	Architectural Coating	Architectural Coating	9/26/2016	2/13/2017	5	101	
6	Paving	Paving	2/9/2017	3/9/2017	5	21	

Acres of Grading (Site Preparation Phase): 0

Acres of Grading (Grading Phase): 3.5

Acres of Paving: 0

Residential Indoor: 0; Residential Outdoor: 0; Non-Residential Indoor: 112,149; Non-Residential Outdoor: 37,383 (Architectural Coating – sqft)

OffRoad Equipment

Phase Name	Offroad Equipment Type	Amount	Usage Hours	Horse Power	Load Factor
Site Preparation	Rubber Tired Dozers	3	8.00	255	0.40
Site Preparation	Tractors/Loaders/Backhoes	4	8.00	97	0.37
Grading	Excavators	1	8.00	162	0.38
Grading	Graders	1	8.00	174	0.41
Grading	Rubber Tired Dozers	1	8.00	255	0.40
Grading	Tractors/Loaders/Backhoes	3	8.00	97	0.37
Building Construction	Cranes	1	7.00	226	0.29
Building Construction	Forklifts	3	8.00	89	0.20
Building Construction	Generator Sets	1	8.00	84	0.74
Building Construction	Tractors/Loaders/Backhoes	3	7.00	97	0.37
Building Construction	Welders	1	8.00	46	0.45
Architectural Coating	Air Compressors	1	6.00	78	0.48
Paving	Pavers	2	8.00	125	0.42
Paving	Paving Equipment	2	8.00	130	0.36
Paving	Rollers	2	8.00	80	0.38

Trips and VMT

Phase Name	Offroad Equipment Count	Worker Trip Number	Vendor Trip Number	Hauling Trip Number	Worker Trip Length	Vendor Trip Length	Hauling Trip Length	Worker Vehicle Class	Vendor Vehicle Class	Hauling Vehicle Class
Site Preparation	7	18.00	0.00	0.00	14.70	6.90	20.00	LD_Mix	HDT_Mix	HHDT
Grading	6	15.00	0.00	1,728.00	14.70	6.90	20.00	LD_Mix	HDT_Mix	HHDT
Building Construction	9	56.00	22.00	0.00	14.70	6.90	20.00	LD_Mix	HDT_Mix	HHDT
Trenching and Utilities				0.00	14.70	6.90				
Architectural Coating	1	11.00	0.00	0.00	14.70	6.90	20.00	LD_Mix	HDT_Mix	HHDT
Paving	6	15.00	0.00	0.00	14.70	6.90	20.00	LD_Mix	HDT_Mix	HHDT

3.1 Mitigation Measures Construction

Use Cleaner Engines for Construction Equipment

Water Exposed Area

Clean Paved Roads

3.2 Site Preparation - 2016

Unmitigated Construction On-Site

	ROG	NOx	CO	SO2	Fugitive PM10	Exhaust PM10	PM10 Total	Fugitive PM2.5	Exhaust PM2.5	PM2.5 Total	Bio- CO2	NBio- CO2	Total CO2	CH4	N2O	CO2e
Category	tons/yr										MT/yr					
Fugitive Dust					0.3794	0.0000	0.3794	0.2085	0.0000	0.2085	0.0000	0.0000	0.0000	0.0000	0.0000	0.0000
Off-Road	0.1066	1.1473	0.8632	8.2000e-004		0.0617	0.0617		0.0568	0.0568	0.0000	77.4419	77.4419	0.0234	0.0000	77.9325
Total	0.1066	1.1473	0.8632	8.2000e-004	0.3794	0.0617	0.4411	0.2085	0.0568	0.2653	0.0000	77.4419	77.4419	0.0234	0.0000	77.9325

3.2 Site Preparation - 2016

Unmitigated Construction Off-Site

	ROG	NOx	CO	SO2	Fugitive PM10	Exhaust PM10	PM10 Total	Fugitive PM2.5	Exhaust PM2.5	PM2.5 Total	Bio- CO2	NBio- CO2	Total CO2	CH4	N2O	CO2e
Category	tons/yr										MT/yr					
Hauling	0.0000	0.0000	0.0000	0.0000	0.0000	0.0000	0.0000	0.0000	0.0000	0.0000	0.0000	0.0000	0.0000	0.0000	0.0000	0.0000
Vendor	0.0000	0.0000	0.0000	0.0000	0.0000	0.0000	0.0000	0.0000	0.0000	0.0000	0.0000	0.0000	0.0000	0.0000	0.0000	0.0000
Worker	1.5200e-003	2.2300e-003	0.0232	5.0000e-005	4.1500e-003	4.0000e-005	4.1800e-003	1.1000e-003	3.0000e-005	1.1300e-003	0.0000	3.8854	3.8854	2.1000e-004	0.0000	3.8898
Total	1.5200e-003	2.2300e-003	0.0232	5.0000e-005	4.1500e-003	4.0000e-005	4.1800e-003	1.1000e-003	3.0000e-005	1.1300e-003	0.0000	3.8854	3.8854	2.1000e-004	0.0000	3.8898

Mitigated Construction On-Site

	ROG	NOx	CO	SO2	Fugitive PM10	Exhaust PM10	PM10 Total	Fugitive PM2.5	Exhaust PM2.5	PM2.5 Total	Bio- CO2	NBio- CO2	Total CO2	CH4	N2O	CO2e
Category	tons/yr										MT/yr					
Fugitive Dust					0.1707	0.0000	0.1707	0.0938	0.0000	0.0938	0.0000	0.0000	0.0000	0.0000	0.0000	0.0000
Off-Road	0.0200	0.4086	0.4914	8.2000e-004		0.0202	0.0202		0.0202	0.0202	0.0000	77.4418	77.4418	0.0234	0.0000	77.9324
Total	0.0200	0.4086	0.4914	8.2000e-004	0.1707	0.0202	0.1909	0.0938	0.0202	0.1140	0.0000	77.4418	77.4418	0.0234	0.0000	77.9324

3.2 Site Preparation - 2016

Mitigated Construction Off-Site

	ROG	NOx	CO	SO2	Fugitive PM10	Exhaust PM10	PM10 Total	Fugitive PM2.5	Exhaust PM2.5	PM2.5 Total	Bio- CO2	NBio- CO2	Total CO2	CH4	N2O	CO2e
Category	tons/yr										MT/yr					
Hauling	0.0000	0.0000	0.0000	0.0000	0.0000	0.0000	0.0000	0.0000	0.0000	0.0000	0.0000	0.0000	0.0000	0.0000	0.0000	0.0000
Vendor	0.0000	0.0000	0.0000	0.0000	0.0000	0.0000	0.0000	0.0000	0.0000	0.0000	0.0000	0.0000	0.0000	0.0000	0.0000	0.0000
Worker	1.5200e-003	2.2300e-003	0.0232	5.0000e-005	4.1500e-003	4.0000e-005	4.1800e-003	1.1000e-003	3.0000e-005	1.1300e-003	0.0000	3.8854	3.8854	2.1000e-004	0.0000	3.8898
Total	1.5200e-003	2.2300e-003	0.0232	5.0000e-005	4.1500e-003	4.0000e-005	4.1800e-003	1.1000e-003	3.0000e-005	1.1300e-003	0.0000	3.8854	3.8854	2.1000e-004	0.0000	3.8898

3.3 Grading - 2016

Unmitigated Construction On-Site

	ROG	NOx	CO	SO2	Fugitive PM10	Exhaust PM10	PM10 Total	Fugitive PM2.5	Exhaust PM2.5	PM2.5 Total	Bio- CO2	NBio- CO2	Total CO2	CH4	N2O	CO2e
Category	tons/yr										MT/yr					
Fugitive Dust					0.3007	0.0000	0.3007	0.1642	0.0000	0.1642	0.0000	0.0000	0.0000	0.0000	0.0000	0.0000
Off-Road	0.1815	1.9031	1.2909	1.4700e-003		0.1088	0.1088		0.1001	0.1001	0.0000	138.9286	138.9286	0.0419	0.0000	139.8086
Total	0.1815	1.9031	1.2909	1.4700e-003	0.3007	0.1088	0.4096	0.1642	0.1001	0.2643	0.0000	138.9286	138.9286	0.0419	0.0000	139.8086

3.3 Grading - 2016

Unmitigated Construction Off-Site

	ROG	NOx	CO	SO2	Fugitive PM10	Exhaust PM10	PM10 Total	Fugitive PM2.5	Exhaust PM2.5	PM2.5 Total	Bio- CO2	NBio- CO2	Total CO2	CH4	N2O	CO2e
Category	tons/yr										MT/yr					
Hauling	0.0154	0.2496	0.1887	6.4000e-004	0.0148	3.7600e-003	0.0186	4.0600e-003	3.4600e-003	7.5200e-003	0.0000	58.1906	58.1906	4.2000e-004	0.0000	58.1994
Vendor	0.0000	0.0000	0.0000	0.0000	0.0000	0.0000	0.0000	0.0000	0.0000	0.0000	0.0000	0.0000	0.0000	0.0000	0.0000	0.0000
Worker	2.9800e-003	4.3800e-003	0.0456	1.0000e-004	8.1500e-003	7.0000e-005	8.2200e-003	2.1600e-003	6.0000e-005	2.2300e-003	0.0000	7.6320	7.6320	4.1000e-004	0.0000	7.6406
Total	0.0184	0.2540	0.2342	7.4000e-004	0.0230	3.8300e-003	0.0268	6.2200e-003	3.5200e-003	9.7500e-003	0.0000	65.8226	65.8226	8.3000e-004	0.0000	65.8400

Mitigated Construction On-Site

	ROG	NOx	CO	SO2	Fugitive PM10	Exhaust PM10	PM10 Total	Fugitive PM2.5	Exhaust PM2.5	PM2.5 Total	Bio- CO2	NBio- CO2	Total CO2	CH4	N2O	CO2e
Category	tons/yr										MT/yr					
Fugitive Dust					0.1353	0.0000	0.1353	0.0739	0.0000	0.0739	0.0000	0.0000	0.0000	0.0000	0.0000	0.0000
Off-Road	0.0359	0.7333	1.0086	1.4700e-003		0.0389	0.0389		0.0389	0.0389	0.0000	138.9284	138.9284	0.0419	0.0000	139.8084
Total	0.0359	0.7333	1.0086	1.4700e-003	0.1353	0.0389	0.1742	0.0739	0.0389	0.1128	0.0000	138.9284	138.9284	0.0419	0.0000	139.8084

3.3 Grading - 2016**Mitigated Construction Off-Site**

	ROG	NOx	CO	SO2	Fugitive PM10	Exhaust PM10	PM10 Total	Fugitive PM2.5	Exhaust PM2.5	PM2.5 Total	Bio- CO2	NBio- CO2	Total CO2	CH4	N2O	CO2e
Category	tons/yr										MT/yr					
Hauling	0.0154	0.2496	0.1887	6.4000e-004	0.0148	3.7600e-003	0.0186	4.0600e-003	3.4600e-003	7.5200e-003	0.0000	58.1906	58.1906	4.2000e-004	0.0000	58.1994
Vendor	0.0000	0.0000	0.0000	0.0000	0.0000	0.0000	0.0000	0.0000	0.0000	0.0000	0.0000	0.0000	0.0000	0.0000	0.0000	0.0000
Worker	2.9800e-003	4.3800e-003	0.0456	1.0000e-004	8.1500e-003	7.0000e-005	8.2200e-003	2.1600e-003	6.0000e-005	2.2300e-003	0.0000	7.6320	7.6320	4.1000e-004	0.0000	7.6406
Total	0.0184	0.2540	0.2342	7.4000e-004	0.0230	3.8300e-003	0.0268	6.2200e-003	3.5200e-003	9.7500e-003	0.0000	65.8226	65.8226	8.3000e-004	0.0000	65.8400

3.4 Building Construction - 2016**Unmitigated Construction On-Site**

	ROG	NOx	CO	SO2	Fugitive PM10	Exhaust PM10	PM10 Total	Fugitive PM2.5	Exhaust PM2.5	PM2.5 Total	Bio- CO2	NBio- CO2	Total CO2	CH4	N2O	CO2e
Category	tons/yr										MT/yr					
Off-Road	0.2538	2.1237	1.3787	2.0000e-003		0.1466	0.1466		0.1377	0.1377	0.0000	180.4044	180.4044	0.0447	0.0000	181.3440
Total	0.2538	2.1237	1.3787	2.0000e-003		0.1466	0.1466		0.1377	0.1377	0.0000	180.4044	180.4044	0.0447	0.0000	181.3440

3.4 Building Construction - 2016

Unmitigated Construction Off-Site

	ROG	NOx	CO	SO2	Fugitive PM10	Exhaust PM10	PM10 Total	Fugitive PM2.5	Exhaust PM2.5	PM2.5 Total	Bio- CO2	NBio- CO2	Total CO2	CH4	N2O	CO2e	
Category	tons/yr										MT/yr						
Hauling	0.0000	0.0000	0.0000	0.0000	0.0000	0.0000	0.0000	0.0000	0.0000	0.0000	0.0000	0.0000	0.0000	0.0000	0.0000	0.0000	0.0000
Vendor	0.0145	0.1480	0.1908	3.6000e-004	0.0101	2.3400e-003	0.0124	2.8800e-003	2.1500e-003	5.0300e-003	0.0000	32.3040	32.3040	2.3000e-004	0.0000	32.3089	
Worker	0.0168	0.0246	0.2560	5.6000e-004	0.0458	3.9000e-004	0.0462	0.0122	3.6000e-004	0.0125	0.0000	42.8829	42.8829	2.3100e-003	0.0000	42.9314	
Total	0.0313	0.1726	0.4467	9.2000e-004	0.0559	2.7300e-003	0.0586	0.0150	2.5100e-003	0.0175	0.0000	75.1869	75.1869	2.5400e-003	0.0000	75.2404	

Mitigated Construction On-Site

	ROG	NOx	CO	SO2	Fugitive PM10	Exhaust PM10	PM10 Total	Fugitive PM2.5	Exhaust PM2.5	PM2.5 Total	Bio- CO2	NBio- CO2	Total CO2	CH4	N2O	CO2e
Category	tons/yr										MT/yr					
Off-Road	0.0500	1.0560	1.3273	2.0000e-003		0.0672	0.0672		0.0672	0.0672	0.0000	180.4042	180.4042	0.0447	0.0000	181.3438
Total	0.0500	1.0560	1.3273	2.0000e-003		0.0672	0.0672		0.0672	0.0672	0.0000	180.4042	180.4042	0.0447	0.0000	181.3438

3.4 Building Construction - 2016

Mitigated Construction Off-Site

	ROG	NOx	CO	SO2	Fugitive PM10	Exhaust PM10	PM10 Total	Fugitive PM2.5	Exhaust PM2.5	PM2.5 Total	Bio- CO2	NBio- CO2	Total CO2	CH4	N2O	CO2e
Category	tons/yr										MT/yr					
Hauling	0.0000	0.0000	0.0000	0.0000	0.0000	0.0000	0.0000	0.0000	0.0000	0.0000	0.0000	0.0000	0.0000	0.0000	0.0000	0.0000
Vendor	0.0145	0.1480	0.1908	3.6000e-004	0.0101	2.3400e-003	0.0124	2.8800e-003	2.1500e-003	5.0300e-003	0.0000	32.3040	32.3040	2.3000e-004	0.0000	32.3089
Worker	0.0168	0.0246	0.2560	5.6000e-004	0.0458	3.9000e-004	0.0462	0.0122	3.6000e-004	0.0125	0.0000	42.8829	42.8829	2.3100e-003	0.0000	42.9314
Total	0.0313	0.1726	0.4467	9.2000e-004	0.0559	2.7300e-003	0.0586	0.0150	2.5100e-003	0.0175	0.0000	75.1869	75.1869	2.5400e-003	0.0000	75.2404

3.4 Building Construction - 2017

Unmitigated Construction On-Site

	ROG	NOx	CO	SO2	Fugitive PM10	Exhaust PM10	PM10 Total	Fugitive PM2.5	Exhaust PM2.5	PM2.5 Total	Bio- CO2	NBio- CO2	Total CO2	CH4	N2O	CO2e
Category	tons/yr										MT/yr					
Off-Road	0.1412	1.2015	0.8249	1.2200e-003		0.0811	0.0811		0.0761	0.0761	0.0000	108.9630	108.9630	0.0268	0.0000	109.5262
Total	0.1412	1.2015	0.8249	1.2200e-003		0.0811	0.0811		0.0761	0.0761	0.0000	108.9630	108.9630	0.0268	0.0000	109.5262

3.4 Building Construction - 2017

Unmitigated Construction Off-Site

	ROG	NOx	CO	SO2	Fugitive PM10	Exhaust PM10	PM10 Total	Fugitive PM2.5	Exhaust PM2.5	PM2.5 Total	Bio- CO2	NBio- CO2	Total CO2	CH4	N2O	CO2e	
Category	tons/yr										MT/yr						
Hauling	0.0000	0.0000	0.0000	0.0000	0.0000	0.0000	0.0000	0.0000	0.0000	0.0000	0.0000	0.0000	0.0000	0.0000	0.0000	0.0000	0.0000
Vendor	8.1200e-003	0.0822	0.1104	2.2000e-004	6.1600e-003	1.2700e-003	7.4400e-003	1.7600e-003	1.1700e-003	2.9300e-003	0.0000	19.4096	19.4096	1.4000e-004	0.0000	19.4125	
Worker	9.1700e-003	0.0136	0.1410	3.4000e-004	0.0280	2.3000e-004	0.0282	7.4200e-003	2.1000e-004	7.6400e-003	0.0000	25.1847	25.1847	1.3000e-003	0.0000	25.2120	
Total	0.0173	0.0958	0.2514	5.6000e-004	0.0341	1.5000e-003	0.0356	9.1800e-003	1.3800e-003	0.0106	0.0000	44.5943	44.5943	1.4400e-003	0.0000	44.6245	

Mitigated Construction On-Site

	ROG	NOx	CO	SO2	Fugitive PM10	Exhaust PM10	PM10 Total	Fugitive PM2.5	Exhaust PM2.5	PM2.5 Total	Bio- CO2	NBio- CO2	Total CO2	CH4	N2O	CO2e
Category	tons/yr										MT/yr					
Off-Road	0.0305	0.6449	0.8106	1.2200e-003		0.0410	0.0410		0.0410	0.0410	0.0000	108.9629	108.9629	0.0268	0.0000	109.5260
Total	0.0305	0.6449	0.8106	1.2200e-003		0.0410	0.0410		0.0410	0.0410	0.0000	108.9629	108.9629	0.0268	0.0000	109.5260

3.5 Trenching and Utilities - 2016

Mitigated Construction Off-Site

	ROG	NOx	CO	SO2	Fugitive PM10	Exhaust PM10	PM10 Total	Fugitive PM2.5	Exhaust PM2.5	PM2.5 Total	Bio- CO2	NBio- CO2	Total CO2	CH4	N2O	CO2e
Category	tons/yr										MT/yr					
Hauling					0.0000	0.0000	0.0000	0.0000	0.0000	0.0000	0.0000	0.0000	0.0000	0.0000	0.0000	0.0000
Vendor					0.0000	0.0000	0.0000	0.0000	0.0000	0.0000	0.0000	0.0000	0.0000	0.0000	0.0000	0.0000
Worker					0.0000	0.0000	0.0000	0.0000	0.0000	0.0000	0.0000	0.0000	0.0000	0.0000	0.0000	0.0000
Total					0.0000	0.0000	0.0000	0.0000	0.0000	0.0000	0.0000	0.0000	0.0000	0.0000	0.0000	0.0000

3.6 Architectural Coating - 2016

Unmitigated Construction On-Site

	ROG	NOx	CO	SO2	Fugitive PM10	Exhaust PM10	PM10 Total	Fugitive PM2.5	Exhaust PM2.5	PM2.5 Total	Bio- CO2	NBio- CO2	Total CO2	CH4	N2O	CO2e
Category	tons/yr										MT/yr					
Archit. Coating	0.3603					0.0000	0.0000		0.0000	0.0000	0.0000	0.0000	0.0000	0.0000	0.0000	0.0000
Off-Road	0.0129	0.0830	0.0659	1.0000e-004		6.8800e-003	6.8800e-003		6.8800e-003	6.8800e-003	0.0000	8.9364	8.9364	1.0500e-003	0.0000	8.9585
Total	0.3732	0.0830	0.0659	1.0000e-004		6.8800e-003	6.8800e-003		6.8800e-003	6.8800e-003	0.0000	8.9364	8.9364	1.0500e-003	0.0000	8.9585

3.6 Architectural Coating - 2016

Unmitigated Construction Off-Site

	ROG	NOx	CO	SO2	Fugitive PM10	Exhaust PM10	PM10 Total	Fugitive PM2.5	Exhaust PM2.5	PM2.5 Total	Bio- CO2	NBio- CO2	Total CO2	CH4	N2O	CO2e
Category	tons/yr										MT/yr					
Hauling	0.0000	0.0000	0.0000	0.0000	0.0000	0.0000	0.0000	0.0000	0.0000	0.0000	0.0000	0.0000	0.0000	0.0000	0.0000	0.0000
Vendor	0.0000	0.0000	0.0000	0.0000	0.0000	0.0000	0.0000	0.0000	0.0000	0.0000	0.0000	0.0000	0.0000	0.0000	0.0000	0.0000
Worker	1.5500e-003	2.2700e-003	0.0236	5.0000e-005	4.2200e-003	4.0000e-005	4.2600e-003	1.1200e-003	3.0000e-005	1.1500e-003	0.0000	3.9573	3.9573	2.1000e-004	0.0000	3.9618
Total	1.5500e-003	2.2700e-003	0.0236	5.0000e-005	4.2200e-003	4.0000e-005	4.2600e-003	1.1200e-003	3.0000e-005	1.1500e-003	0.0000	3.9573	3.9573	2.1000e-004	0.0000	3.9618

Mitigated Construction On-Site

	ROG	NOx	CO	SO2	Fugitive PM10	Exhaust PM10	PM10 Total	Fugitive PM2.5	Exhaust PM2.5	PM2.5 Total	Bio- CO2	NBio- CO2	Total CO2	CH4	N2O	CO2e
Category	tons/yr										MT/yr					
Archit. Coating	0.3603					0.0000	0.0000		0.0000	0.0000	0.0000	0.0000	0.0000	0.0000	0.0000	0.0000
Off-Road	2.0800e-003	0.0475	0.0641	1.0000e-004		3.3300e-003	3.3300e-003		3.3300e-003	3.3300e-003	0.0000	8.9364	8.9364	1.0500e-003	0.0000	8.9585
Total	0.3623	0.0475	0.0641	1.0000e-004		3.3300e-003	3.3300e-003		3.3300e-003	3.3300e-003	0.0000	8.9364	8.9364	1.0500e-003	0.0000	8.9585

3.6 Architectural Coating - 2016

Mitigated Construction Off-Site

	ROG	NOx	CO	SO2	Fugitive PM10	Exhaust PM10	PM10 Total	Fugitive PM2.5	Exhaust PM2.5	PM2.5 Total	Bio- CO2	NBio- CO2	Total CO2	CH4	N2O	CO2e
Category	tons/yr										MT/yr					
Hauling	0.0000	0.0000	0.0000	0.0000	0.0000	0.0000	0.0000	0.0000	0.0000	0.0000	0.0000	0.0000	0.0000	0.0000	0.0000	0.0000
Vendor	0.0000	0.0000	0.0000	0.0000	0.0000	0.0000	0.0000	0.0000	0.0000	0.0000	0.0000	0.0000	0.0000	0.0000	0.0000	0.0000
Worker	1.5500e-003	2.2700e-003	0.0236	5.0000e-005	4.2200e-003	4.0000e-005	4.2600e-003	1.1200e-003	3.0000e-005	1.1500e-003	0.0000	3.9573	3.9573	2.1000e-004	0.0000	3.9618
Total	1.5500e-003	2.2700e-003	0.0236	5.0000e-005	4.2200e-003	4.0000e-005	4.2600e-003	1.1200e-003	3.0000e-005	1.1500e-003	0.0000	3.9573	3.9573	2.1000e-004	0.0000	3.9618

3.6 Architectural Coating - 2017

Unmitigated Construction On-Site

	ROG	NOx	CO	SO2	Fugitive PM10	Exhaust PM10	PM10 Total	Fugitive PM2.5	Exhaust PM2.5	PM2.5 Total	Bio- CO2	NBio- CO2	Total CO2	CH4	N2O	CO2e
Category	tons/yr										MT/yr					
Archit. Coating	0.1596					0.0000	0.0000		0.0000	0.0000	0.0000	0.0000	0.0000	0.0000	0.0000	0.0000
Off-Road	5.1500e-003	0.0339	0.0290	5.0000e-005		2.6900e-003	2.6900e-003		2.6900e-003	2.6900e-003	0.0000	3.9575	3.9575	4.2000e-004	0.0000	3.9663
Total	0.1647	0.0339	0.0290	5.0000e-005		2.6900e-003	2.6900e-003		2.6900e-003	2.6900e-003	0.0000	3.9575	3.9575	4.2000e-004	0.0000	3.9663

3.6 Architectural Coating - 2017

Unmitigated Construction Off-Site

	ROG	NOx	CO	SO2	Fugitive PM10	Exhaust PM10	PM10 Total	Fugitive PM2.5	Exhaust PM2.5	PM2.5 Total	Bio- CO2	NBio- CO2	Total CO2	CH4	N2O	CO2e
Category	tons/yr										MT/yr					
Hauling	0.0000	0.0000	0.0000	0.0000	0.0000	0.0000	0.0000	0.0000	0.0000	0.0000	0.0000	0.0000	0.0000	0.0000	0.0000	0.0000
Vendor	0.0000	0.0000	0.0000	0.0000	0.0000	0.0000	0.0000	0.0000	0.0000	0.0000	0.0000	0.0000	0.0000	0.0000	0.0000	0.0000
Worker	6.1000e-004	9.1000e-004	9.4300e-003	2.0000e-005	1.8700e-003	2.0000e-005	1.8900e-003	5.0000e-004	1.0000e-005	5.1000e-004	0.0000	1.6852	1.6852	9.0000e-005	0.0000	1.6871
Total	6.1000e-004	9.1000e-004	9.4300e-003	2.0000e-005	1.8700e-003	2.0000e-005	1.8900e-003	5.0000e-004	1.0000e-005	5.1000e-004	0.0000	1.6852	1.6852	9.0000e-005	0.0000	1.6871

Mitigated Construction On-Site

	ROG	NOx	CO	SO2	Fugitive PM10	Exhaust PM10	PM10 Total	Fugitive PM2.5	Exhaust PM2.5	PM2.5 Total	Bio- CO2	NBio- CO2	Total CO2	CH4	N2O	CO2e
Category	tons/yr										MT/yr					
Archit. Coating	0.1596					0.0000	0.0000		0.0000	0.0000	0.0000	0.0000	0.0000	0.0000	0.0000	0.0000
Off-Road	9.2000e-004	0.0210	0.0284	5.0000e-005		1.4700e-003	1.4700e-003		1.4700e-003	1.4700e-003	0.0000	3.9575	3.9575	4.2000e-004	0.0000	3.9663
Total	0.1605	0.0210	0.0284	5.0000e-005		1.4700e-003	1.4700e-003		1.4700e-003	1.4700e-003	0.0000	3.9575	3.9575	4.2000e-004	0.0000	3.9663

3.6 Architectural Coating - 2017

Mitigated Construction Off-Site

	ROG	NOx	CO	SO2	Fugitive PM10	Exhaust PM10	PM10 Total	Fugitive PM2.5	Exhaust PM2.5	PM2.5 Total	Bio- CO2	NBio- CO2	Total CO2	CH4	N2O	CO2e
Category	tons/yr										MT/yr					
Hauling	0.0000	0.0000	0.0000	0.0000	0.0000	0.0000	0.0000	0.0000	0.0000	0.0000	0.0000	0.0000	0.0000	0.0000	0.0000	0.0000
Vendor	0.0000	0.0000	0.0000	0.0000	0.0000	0.0000	0.0000	0.0000	0.0000	0.0000	0.0000	0.0000	0.0000	0.0000	0.0000	0.0000
Worker	6.1000e-004	9.1000e-004	9.4300e-003	2.0000e-005	1.8700e-003	2.0000e-005	1.8900e-003	5.0000e-004	1.0000e-005	5.1000e-004	0.0000	1.6852	1.6852	9.0000e-005	0.0000	1.6871
Total	6.1000e-004	9.1000e-004	9.4300e-003	2.0000e-005	1.8700e-003	2.0000e-005	1.8900e-003	5.0000e-004	1.0000e-005	5.1000e-004	0.0000	1.6852	1.6852	9.0000e-005	0.0000	1.6871

3.7 Paving - 2017

Unmitigated Construction On-Site

	ROG	NOx	CO	SO2	Fugitive PM10	Exhaust PM10	PM10 Total	Fugitive PM2.5	Exhaust PM2.5	PM2.5 Total	Bio- CO2	NBio- CO2	Total CO2	CH4	N2O	CO2e
Category	tons/yr										MT/yr					
Off-Road	0.0200	0.2131	0.1546	2.3000e-004		0.0120	0.0120		0.0110	0.0110	0.0000	21.7281	21.7281	6.6600e-003	0.0000	21.8679
Paving	1.7800e-003					0.0000	0.0000		0.0000	0.0000	0.0000	0.0000	0.0000	0.0000	0.0000	0.0000
Total	0.0218	0.2131	0.1546	2.3000e-004		0.0120	0.0120		0.0110	0.0110	0.0000	21.7281	21.7281	6.6600e-003	0.0000	21.8679

3.7 Paving - 2017**Unmitigated Construction Off-Site**

	ROG	NOx	CO	SO2	Fugitive PM10	Exhaust PM10	PM10 Total	Fugitive PM2.5	Exhaust PM2.5	PM2.5 Total	Bio- CO2	NBio- CO2	Total CO2	CH4	N2O	CO2e
Category	tons/yr										MT/yr					
Hauling	0.0000	0.0000	0.0000	0.0000	0.0000	0.0000	0.0000	0.0000	0.0000	0.0000	0.0000	0.0000	0.0000	0.0000	0.0000	0.0000
Vendor	0.0000	0.0000	0.0000	0.0000	0.0000	0.0000	0.0000	0.0000	0.0000	0.0000	0.0000	0.0000	0.0000	0.0000	0.0000	0.0000
Worker	5.7000e-004	8.4000e-004	8.7200e-003	2.0000e-005	1.7300e-003	1.0000e-005	1.7400e-003	4.6000e-004	1.0000e-005	4.7000e-004	0.0000	1.5568	1.5568	8.0000e-005	0.0000	1.5584
Total	5.7000e-004	8.4000e-004	8.7200e-003	2.0000e-005	1.7300e-003	1.0000e-005	1.7400e-003	4.6000e-004	1.0000e-005	4.7000e-004	0.0000	1.5568	1.5568	8.0000e-005	0.0000	1.5584

Mitigated Construction On-Site

	ROG	NOx	CO	SO2	Fugitive PM10	Exhaust PM10	PM10 Total	Fugitive PM2.5	Exhaust PM2.5	PM2.5 Total	Bio- CO2	NBio- CO2	Total CO2	CH4	N2O	CO2e
Category	tons/yr										MT/yr					
Off-Road	5.7600e-003	0.1162	0.1777	2.3000e-004		6.2800e-003	6.2800e-003		6.2800e-003	6.2800e-003	0.0000	21.7281	21.7281	6.6600e-003	0.0000	21.8679
Paving	1.7800e-003					0.0000	0.0000		0.0000	0.0000	0.0000	0.0000	0.0000	0.0000	0.0000	0.0000
Total	7.5400e-003	0.1162	0.1777	2.3000e-004		6.2800e-003	6.2800e-003		6.2800e-003	6.2800e-003	0.0000	21.7281	21.7281	6.6600e-003	0.0000	21.8679

3.7 Paving - 2017

Mitigated Construction Off-Site

	ROG	NOx	CO	SO2	Fugitive PM10	Exhaust PM10	PM10 Total	Fugitive PM2.5	Exhaust PM2.5	PM2.5 Total	Bio- CO2	NBio- CO2	Total CO2	CH4	N2O	CO2e
Category	tons/yr										MT/yr					
Hauling	0.0000	0.0000	0.0000	0.0000	0.0000	0.0000	0.0000	0.0000	0.0000	0.0000	0.0000	0.0000	0.0000	0.0000	0.0000	0.0000
Vendor	0.0000	0.0000	0.0000	0.0000	0.0000	0.0000	0.0000	0.0000	0.0000	0.0000	0.0000	0.0000	0.0000	0.0000	0.0000	0.0000
Worker	5.7000e-004	8.4000e-004	8.7200e-003	2.0000e-005	1.7300e-003	1.0000e-005	1.7400e-003	4.6000e-004	1.0000e-005	4.7000e-004	0.0000	1.5568	1.5568	8.0000e-005	0.0000	1.5584
Total	5.7000e-004	8.4000e-004	8.7200e-003	2.0000e-005	1.7300e-003	1.0000e-005	1.7400e-003	4.6000e-004	1.0000e-005	4.7000e-004	0.0000	1.5568	1.5568	8.0000e-005	0.0000	1.5584

4.0 Operational Detail - Mobile

4.1 Mitigation Measures Mobile

	ROG	NOx	CO	SO2	Fugitive PM10	Exhaust PM10	PM10 Total	Fugitive PM2.5	Exhaust PM2.5	PM2.5 Total	Bio- CO2	NBio- CO2	Total CO2	CH4	N2O	CO2e
Category	tons/yr										MT/yr					
Mitigated	0.5255	1.3877	5.4538	0.0134	0.9023	0.0193	0.9216	0.2415	0.0178	0.2593	0.0000	1,002.5180	1,002.5180	0.0385	0.0000	1,003.3264
Unmitigated	0.5255	1.3877	5.4538	0.0134	0.9023	0.0193	0.9216	0.2415	0.0178	0.2593	0.0000	1,002.5180	1,002.5180	0.0385	0.0000	1,003.3264

4.2 Trip Summary Information

Land Use	Average Daily Trip Rate			Unmitigated	Mitigated
	Weekday	Saturday	Sunday	Annual VMT	Annual VMT
Hotel	1,037.59	1,040.13	755.65	2,380,625	2,380,625
Parking Lot	0.00	0.00	0.00		
Total	1,037.59	1,040.13	755.65	2,380,625	2,380,625

4.3 Trip Type Information

Land Use	Miles			Trip %			Trip Purpose %		
	H-W or C-W	H-S or C-C	H-O or C-NW	H-W or C-W	H-S or C-C	H-O or C-NW	Primary	Diverted	Pass-by
Hotel	16.60	8.40	6.90	19.40	61.60	19.00	58	38	4
Parking Lot	16.60	8.40	6.90	0.00	0.00	0.00	0	0	0

LDA	LDT1	LDT2	MDV	LHD1	LHD2	MHD	HHD	OBUS	UBUS	MCY	SBUS	MH
0.511172	0.060004	0.180590	0.138995	0.042398	0.006681	0.016070	0.032568	0.001938	0.002493	0.004370	0.000586	0.002135

5.0 Energy Detail

4.4 Fleet Mix

Historical Energy Use: N

5.1 Mitigation Measures Energy

	ROG	NOx	CO	SO2	Fugitive PM10	Exhaust PM10	PM10 Total	Fugitive PM2.5	Exhaust PM2.5	PM2.5 Total	Bio- CO2	NBio- CO2	Total CO2	CH4	N2O	CO2e
Category	tons/yr										MT/yr					
Electricity Mitigated						0.0000	0.0000		0.0000	0.0000	0.0000	192.6650	192.6650	8.8600e-003	1.8300e-003	193.4190
Electricity Unmitigated						0.0000	0.0000		0.0000	0.0000	0.0000	192.6650	192.6650	8.8600e-003	1.8300e-003	193.4190
NaturalGas Mitigated	9.8400e-003	0.0895	0.0752	5.4000e-004		6.8000e-003	6.8000e-003		6.8000e-003	6.8000e-003	0.0000	97.4054	97.4054	1.8700e-003	1.7900e-003	97.9982
NaturalGas Unmitigated	9.8400e-003	0.0895	0.0752	5.4000e-004		6.8000e-003	6.8000e-003		6.8000e-003	6.8000e-003	0.0000	97.4054	97.4054	1.8700e-003	1.7900e-003	97.9982

5.2 Energy by Land Use - NaturalGas
Unmitigated

	NaturalGas Use	ROG	NOx	CO	SO2	Fugitive PM10	Exhaust PM10	PM10 Total	Fugitive PM2.5	Exhaust PM2.5	PM2.5 Total	Bio- CO2	NBio- CO2	Total CO2	CH4	N2O	CO2e
Land Use	kBTU/yr	tons/yr										MT/yr					
Parking Lot	0	0.0000	0.0000	0.0000	0.0000		0.0000	0.0000		0.0000	0.0000	0.0000	0.0000	0.0000	0.0000	0.0000	0.0000
Hotel	1.82531e+006	9.8400e-003	0.0895	0.0752	5.4000e-004		6.8000e-003	6.8000e-003		6.8000e-003	6.8000e-003	0.0000	97.4054	97.4054	1.8700e-003	1.7900e-003	97.9982
Total		9.8400e-003	0.0895	0.0752	5.4000e-004		6.8000e-003	6.8000e-003		6.8000e-003	6.8000e-003	0.0000	97.4054	97.4054	1.8700e-003	1.7900e-003	97.9982

5.2 Energy by Land Use - NaturalGas

Mitigated

	NaturalGas Use	ROG	NOx	CO	SO2	Fugitive PM10	Exhaust PM10	PM10 Total	Fugitive PM2.5	Exhaust PM2.5	PM2.5 Total	Bio- CO2	NBio- CO2	Total CO2	CH4	N2O	CO2e	
Land Use	kBTU/yr	tons/yr										MT/yr						
Parking Lot	0	0.0000	0.0000	0.0000	0.0000		0.0000	0.0000		0.0000	0.0000	0.0000	0.0000	0.0000	0.0000	0.0000	0.0000	0.0000
Hotel	1.82531e+006	9.8400e-003	0.0895	0.0752	5.4000e-004		6.8000e-003	6.8000e-003		6.8000e-003	6.8000e-003	0.0000	97.4054	97.4054	1.8700e-003	1.7900e-003	97.9982	
Total		9.8400e-003	0.0895	0.0752	5.4000e-004		6.8000e-003	6.8000e-003		6.8000e-003	6.8000e-003	0.0000	97.4054	97.4054	1.8700e-003	1.7900e-003	97.9982	

5.3 Energy by Land Use - Electricity

Unmitigated

	Electricity Use	Total CO2	CH4	N2O	CO2e
Land Use	kWh/yr	MT/yr			
Hotel	620109	177.4547	8.1600e-003	1.6900e-003	178.1491
Parking Lot	53152	15.2103	7.0000e-004	1.4000e-004	15.2699
Total		192.6650	8.8600e-003	1.8300e-003	193.4190

5.3 Energy by Land Use - Electricity

Mitigated

	Electricity Use	Total CO2	CH4	N2O	CO2e
Land Use	kWh/yr	MT/yr			
Hotel	620109	177.4547	8.1600e-003	1.6900e-003	178.1491
Parking Lot	53152	15.2103	7.0000e-004	1.4000e-004	15.2699
Total		192.6650	8.8600e-003	1.8300e-003	193.4190

6.0 Area Detail

6.1 Mitigation Measures Area

Use Low VOC Paint - Non-Residential Interior

Use Low VOC Paint - Non-Residential Exterior

Use only Natural Gas Hearths

	ROG	NOx	CO	SO2	Fugitive PM10	Exhaust PM10	PM10 Total	Fugitive PM2.5	Exhaust PM2.5	PM2.5 Total	Bio- CO2	NBio- CO2	Total CO2	CH4	N2O	CO2e
Category	tons/yr										MT/yr					
Mitigated	0.5342	3.0000e-005	3.6000e-003	0.0000		1.0000e-005	1.0000e-005		1.0000e-005	1.0000e-005	0.0000	6.9000e-003	6.9000e-003	2.0000e-005	0.0000	7.3000e-003
Unmitigated	0.5602	3.0000e-005	3.6000e-003	0.0000		1.0000e-005	1.0000e-005		1.0000e-005	1.0000e-005	0.0000	6.9000e-003	6.9000e-003	2.0000e-005	0.0000	7.3000e-003

6.2 Area by SubCategory

Unmitigated

	ROG	NOx	CO	SO2	Fugitive PM10	Exhaust PM10	PM10 Total	Fugitive PM2.5	Exhaust PM2.5	PM2.5 Total	Bio- CO2	NBio- CO2	Total CO2	CH4	N2O	CO2e
SubCategory	tons/yr										MT/yr					
Architectural Coating	0.0780					0.0000	0.0000		0.0000	0.0000	0.0000	0.0000	0.0000	0.0000	0.0000	0.0000
Consumer Products	0.4819					0.0000	0.0000		0.0000	0.0000	0.0000	0.0000	0.0000	0.0000	0.0000	0.0000
Landscaping	3.4000e-004	3.0000e-005	3.6000e-003	0.0000		1.0000e-005	1.0000e-005		1.0000e-005	1.0000e-005	0.0000	6.9000e-003	6.9000e-003	2.0000e-005	0.0000	7.3000e-003
Total	0.5602	3.0000e-005	3.6000e-003	0.0000		1.0000e-005	1.0000e-005		1.0000e-005	1.0000e-005	0.0000	6.9000e-003	6.9000e-003	2.0000e-005	0.0000	7.3000e-003

6.2 Area by SubCategory

Mitigated

	ROG	NOx	CO	SO2	Fugitive PM10	Exhaust PM10	PM10 Total	Fugitive PM2.5	Exhaust PM2.5	PM2.5 Total	Bio- CO2	NBio- CO2	Total CO2	CH4	N2O	CO2e
SubCategory	tons/yr										MT/yr					
Architectural Coating	0.0520					0.0000	0.0000		0.0000	0.0000	0.0000	0.0000	0.0000	0.0000	0.0000	0.0000
Consumer Products	0.4819					0.0000	0.0000		0.0000	0.0000	0.0000	0.0000	0.0000	0.0000	0.0000	0.0000
Landscaping	3.4000e-004	3.0000e-005	3.6000e-003	0.0000		1.0000e-005	1.0000e-005		1.0000e-005	1.0000e-005	0.0000	6.9000e-003	6.9000e-003	2.0000e-005	0.0000	7.3000e-003
Total	0.5342	3.0000e-005	3.6000e-003	0.0000		1.0000e-005	1.0000e-005		1.0000e-005	1.0000e-005	0.0000	6.9000e-003	6.9000e-003	2.0000e-005	0.0000	7.3000e-003

7.0 Water Detail

7.1 Mitigation Measures Water

	Total CO2	CH4	N2O	CO2e
Category	MT/yr			
Mitigated	14.1643	0.1056	2.6000e-003	17.1870
Unmitigated	14.1643	0.1056	2.6000e-003	17.1886

7.2 Water by Land Use

Unmitigated

	Indoor/Outdoor Use	Total CO2	CH4	N2O	CO2e
Land Use	Mgal	MT/yr			
Hotel	3.22158 / 0.357953	14.1643	0.1056	2.6000e-003	17.1886
Parking Lot	0 / 0	0.0000	0.0000	0.0000	0.0000
Total		14.1643	0.1056	2.6000e-003	17.1886

Mitigated

	Indoor/Outdoor Use	Total CO2	CH4	N2O	CO2e
Land Use	Mgal	MT/yr			
Hotel	3.22158 / 0.357953	14.1643	0.1056	2.6000e-003	17.1870
Parking Lot	0 / 0	0.0000	0.0000	0.0000	0.0000
Total		14.1643	0.1056	2.6000e-003	17.1870

8.0 Waste Detail

8.1 Mitigation Measures Waste

Category/Year

	Total CO2	CH4	N2O	CO2e
	MT/yr			
Mitigated	14.1140	0.8341	0.0000	31.6303
Unmitigated	14.1140	0.8341	0.0000	31.6303

8.2 Waste by Land Use

Unmitigated

	Waste Disposed	Total CO2	CH4	N2O	CO2e
Land Use	tons	MT/yr			
Hotel	69.53	14.1140	0.8341	0.0000	31.6303
Parking Lot	0	0.0000	0.0000	0.0000	0.0000
Total		14.1140	0.8341	0.0000	31.6303

8.2 Waste by Land Use

Mitigated

	Waste Disposed	Total CO2	CH4	N2O	CO2e
Land Use	tons	MT/yr			
Hotel	69.53	14.1140	0.8341	0.0000	31.6303
Parking Lot	0	0.0000	0.0000	0.0000	0.0000
Total		14.1140	0.8341	0.0000	31.6303

9.0 Operational Offroad

Equipment Type	Number	Hours/Day	Days/Year	Horse Power	Load Factor	Fuel Type
----------------	--------	-----------	-----------	-------------	-------------	-----------

10.0 Vegetation

Rondell Oasis Hotel Project
South Coast AQMD Air District, Summer

1.0 Project Characteristics

1.1 Land Usage

Land Uses	Size	Metric	Lot Acreage	Floor Surface Area	Population
Parking Lot	151.00	Space	1.36	60,400.00	0
Hotel	127.00	Room	3.64	72,954.00	0

1.2 Other Project Characteristics

Urbanization	Urban	Wind Speed (m/s)	2.2	Precipitation Freq (Days)	31
Climate Zone	9			Operational Year	2018
Utility Company	Southern California Edison				
CO2 Intensity (lb/MWhr)	630.89	CH4 Intensity (lb/MWhr)	0.029	N2O Intensity (lb/MWhr)	0.006

1.3 User Entered Comments & Non-Default Data

Project Characteristics - Operational year would be 2017, however, for the purposes of CalEEMod, the operational year input must be a year after all construction ends.

Land Use - Square feet of total building area from Nadel Residential & Commercial Inc., Site Plan, 2/13/2015. Project site approximately 5 acres.

Construction Phase - Applicant provided construction schedule.

Grading - Export from applicant provided grading quantities. Construction would occur on approximately 3.5 acres of the project site.

Architectural Coating - Use of low-VOC paint (150 g/L for nonflat coatings) as required by SCAQMD Rule 1113.

Vehicle Trips - Default vehicle trip rates consistent with Traffic Impact Analysis prepared by Overland Traffic Consultants, Inc. (December 2014).

Woodstoves - Project does not include woodstoves or wood burning fireplaces.

Area Coating - Use of low-VOC paint (150 g/L for nonflat coatings) as required by SCAQMD Rule 1113.

Energy Use -

Construction Off-road Equipment Mitigation - Compliance with SCAQMD Fugitive Dust Rule 403. Assumes that equipment used would comply with current EPA and ARB Tier 3 standards for nonroad diesel engines.

Area Mitigation - Use of low-VOC paint (150 g/L for nonflat coatings) as required by SCAQMD Rule 1113. Project would include at most one natural gas hearth and no wood burning hearths or woodstoves.

Trips and VMT -

Table Name	Column Name	Default Value	New Value
tblArchitecturalCoating	EF_Nonresidential_Exterior	250.00	150.00
tblArchitecturalCoating	EF_Nonresidential_Interior	250.00	150.00
tblAreaCoating	Area_EF_Nonresidential_Exterior	250	150
tblAreaMitigation	UseLowVOCPaintNonresidentialInteriorValue	250	150
tblConstEquipMitigation	NumberOfEquipmentMitigated	0.00	1.00
tblConstEquipMitigation	NumberOfEquipmentMitigated	0.00	1.00
tblConstEquipMitigation	NumberOfEquipmentMitigated	0.00	1.00
tblConstEquipMitigation	NumberOfEquipmentMitigated	0.00	3.00
tblConstEquipMitigation	NumberOfEquipmentMitigated	0.00	1.00
tblConstEquipMitigation	NumberOfEquipmentMitigated	0.00	1.00
tblConstEquipMitigation	NumberOfEquipmentMitigated	0.00	2.00
tblConstEquipMitigation	NumberOfEquipmentMitigated	0.00	2.00
tblConstEquipMitigation	NumberOfEquipmentMitigated	0.00	2.00

tblConstEquipMitigation	NumberOfEquipmentMitigated	0.00	4.00
tblConstEquipMitigation	NumberOfEquipmentMitigated	0.00	10.00
tblConstEquipMitigation	NumberOfEquipmentMitigated	0.00	1.00
tblConstEquipMitigation	Tier	No Change	Tier 3
tblConstEquipMitigation	Tier	No Change	Tier 3
tblConstEquipMitigation	Tier	No Change	Tier 3
tblConstEquipMitigation	Tier	No Change	Tier 3
tblConstEquipMitigation	Tier	No Change	Tier 3
tblConstEquipMitigation	Tier	No Change	Tier 3
tblConstEquipMitigation	Tier	No Change	Tier 3
tblConstEquipMitigation	Tier	No Change	Tier 3
tblConstEquipMitigation	Tier	No Change	Tier 3
tblConstEquipMitigation	Tier	No Change	Tier 3
tblConstEquipMitigation	Tier	No Change	Tier 3
tblConstEquipMitigation	Tier	No Change	Tier 3
tblConstructionPhase	NumDays	18.00	101.00
tblConstructionPhase	NumDays	230.00	240.00
tblConstructionPhase	NumDays	8.00	99.00
tblConstructionPhase	NumDays	18.00	21.00
tblConstructionPhase	NumDays	5.00	42.00
tblConstructionPhase	PhaseEndDate	12/1/2016	2/13/2017
tblConstructionPhase	PhaseEndDate	8/15/2017	5/8/2017
tblConstructionPhase	PhaseEndDate	10/21/2016	9/13/2016
tblConstructionPhase	PhaseEndDate	3/14/2017	3/9/2017
tblConstructionPhase	PhaseEndDate	6/12/2017	7/13/2016
tblConstructionPhase	PhaseStartDate	7/14/2016	9/26/2016
tblConstructionPhase	PhaseStartDate	9/14/2016	6/7/2016
tblConstructionPhase	PhaseStartDate	6/7/2016	4/28/2016

tblConstructionPhase	PhaseStartDate	2/14/2017	2/9/2017
tblConstructionPhase	PhaseStartDate	5/9/2017	6/9/2016
tblGrading	AcresOfGrading	49.50	3.50
tblGrading	MaterialExported	0.00	13,820.00
tblLandUse	LandUseSquareFeet	184,404.00	72,954.00
tblLandUse	LotAcreage	4.23	3.64
tblProjectCharacteristics	OperationalYear	2014	2018

2.0 Emissions Summary

2.2 Overall Operational

Unmitigated Operational

	ROG	NOx	CO	SO2	Fugitive PM10	Exhaust PM10	PM10 Total	Fugitive PM2.5	Exhaust PM2.5	PM2.5 Total	Bio- CO2	NBio- CO2	Total CO2	CH4	N2O	CO2e
Category	lb/day										lb/day					
Area	3.0704	2.7000e-004	0.0288	0.0000		1.0000e-004	1.0000e-004		1.0000e-004	1.0000e-004		0.0608	0.0608	1.7000e-004		0.0644
Energy	0.0539	0.4903	0.4118	2.9400e-003		0.0373	0.0373		0.0373	0.0373		588.3349	588.3349	0.0113	0.0108	591.9154
Mobile	3.0716	7.4373	30.8256	0.0797	5.2643	0.1107	5.3750	1.4066	0.1020	1.5086		6,575.0266	6,575.0266	0.2433		6,580.1351
Total	6.1959	7.9278	31.2662	0.0826	5.2643	0.1481	5.4124	1.4066	0.1393	1.5460		7,163.4224	7,163.4224	0.2547	0.0108	7,172.1149

Mitigated Operational

	ROG	NOx	CO	SO2	Fugitive PM10	Exhaust PM10	PM10 Total	Fugitive PM2.5	Exhaust PM2.5	PM2.5 Total	Bio- CO2	NBio- CO2	Total CO2	CH4	N2O	CO2e
Category	lb/day										lb/day					
Area	2.9280	2.7000e-004	0.0288	0.0000		1.0000e-004	1.0000e-004		1.0000e-004	1.0000e-004		0.0608	0.0608	1.7000e-004		0.0644
Energy	0.0539	0.4903	0.4118	2.9400e-003		0.0373	0.0373		0.0373	0.0373		588.3349	588.3349	0.0113	0.0108	591.9154
Mobile	3.0716	7.4373	30.8256	0.0797	5.2643	0.1107	5.3750	1.4066	0.1020	1.5086		6,575.0266	6,575.0266	0.2433		6,580.1351
Total	6.0535	7.9278	31.2662	0.0826	5.2643	0.1481	5.4124	1.4066	0.1393	1.5460		7,163.4224	7,163.4224	0.2547	0.0108	7,172.1149

	ROG	NOx	CO	SO2	Fugitive PM10	Exhaust PM10	PM10 Total	Fugitive PM2.5	Exhaust PM2.5	PM2.5 Total	Bio- CO2	NBio-CO2	Total CO2	CH4	N2O	CO2e
Percent Reduction	2.30	0.00	0.00	0.00	0.00	0.00	0.00	0.00	0.00	0.00	0.00	0.00	0.00	0.00	0.00	0.00

3.0 Construction Detail

Construction Phase

Phase Number	Phase Name	Phase Type	Start Date	End Date	Num Days Week	Num Days	Phase Description
1	Site Preparation	Site Preparation	4/8/2016	6/6/2016	5	42	
2	Grading	Grading	4/28/2016	9/13/2016	5	99	
3	Building Construction	Building Construction	6/7/2016	5/8/2017	5	240	
4	Trenching and Utilities	Trenching	6/9/2016	7/13/2016	5	25	
5	Architectural Coating	Architectural Coating	9/26/2016	2/13/2017	5	101	
6	Paving	Paving	2/9/2017	3/9/2017	5	21	

Acres of Grading (Site Preparation Phase): 0

Acres of Grading (Grading Phase): 3.5

Acres of Paving: 0

Residential Indoor: 0; Residential Outdoor: 0; Non-Residential Indoor: 112,149; Non-Residential Outdoor: 37,383 (Architectural Coating – sqft)

OffRoad Equipment

Phase Name	Offroad Equipment Type	Amount	Usage Hours	Horse Power	Load Factor
Site Preparation	Rubber Tired Dozers	3	8.00	255	0.40
Site Preparation	Tractors/Loaders/Backhoes	4	8.00	97	0.37
Grading	Excavators	1	8.00	162	0.38
Grading	Graders	1	8.00	174	0.41
Grading	Rubber Tired Dozers	1	8.00	255	0.40
Grading	Tractors/Loaders/Backhoes	3	8.00	97	0.37
Building Construction	Cranes	1	7.00	226	0.29
Building Construction	Forklifts	3	8.00	89	0.20
Building Construction	Generator Sets	1	8.00	84	0.74
Building Construction	Tractors/Loaders/Backhoes	3	7.00	97	0.37
Building Construction	Welders	1	8.00	46	0.45
Architectural Coating	Air Compressors	1	6.00	78	0.48
Paving	Pavers	2	8.00	125	0.42
Paving	Paving Equipment	2	8.00	130	0.36
Paving	Rollers	2	8.00	80	0.38

Trips and VMT

Phase Name	Offroad Equipment Count	Worker Trip Number	Vendor Trip Number	Hauling Trip Number	Worker Trip Length	Vendor Trip Length	Hauling Trip Length	Worker Vehicle Class	Vendor Vehicle Class	Hauling Vehicle Class
Site Preparation	7	18.00	0.00	0.00	14.70	6.90	20.00	LD_Mix	HDT_Mix	HHDT
Grading	6	15.00	0.00	1,728.00	14.70	6.90	20.00	LD_Mix	HDT_Mix	HHDT
Building Construction	9	56.00	22.00	0.00	14.70	6.90	20.00	LD_Mix	HDT_Mix	HHDT
Trenching and Utilities				0.00	14.70	6.90				
Architectural Coating	1	11.00	0.00	0.00	14.70	6.90	20.00	LD_Mix	HDT_Mix	HHDT
Paving	6	15.00	0.00	0.00	14.70	6.90	20.00	LD_Mix	HDT_Mix	HHDT

3.1 Mitigation Measures Construction

Use Cleaner Engines for Construction Equipment

Water Exposed Area

Clean Paved Roads

3.2 Site Preparation - 2016

Unmitigated Construction On-Site

	ROG	NOx	CO	SO2	Fugitive PM10	Exhaust PM10	PM10 Total	Fugitive PM2.5	Exhaust PM2.5	PM2.5 Total	Bio- CO2	NBio- CO2	Total CO2	CH4	N2O	CO2e
Category	lb/day										lb/day					
Fugitive Dust					18.0663	0.0000	18.0663	9.9307	0.0000	9.9307			0.0000			0.0000
Off-Road	5.0771	54.6323	41.1053	0.0391		2.9387	2.9387		2.7036	2.7036		4,065.005 3	4,065.005 3	1.2262		4,090.754 4
Total	5.0771	54.6323	41.1053	0.0391	18.0663	2.9387	21.0049	9.9307	2.7036	12.6343		4,065.005 3	4,065.005 3	1.2262		4,090.754 4

3.2 Site Preparation - 2016

Unmitigated Construction Off-Site

	ROG	NOx	CO	SO2	Fugitive PM10	Exhaust PM10	PM10 Total	Fugitive PM2.5	Exhaust PM2.5	PM2.5 Total	Bio- CO2	NBio- CO2	Total CO2	CH4	N2O	CO2e	
Category	lb/day										lb/day						
Hauling	0.0000	0.0000	0.0000	0.0000	0.0000	0.0000	0.0000	0.0000	0.0000	0.0000		0.0000	0.0000	0.0000			0.0000
Vendor	0.0000	0.0000	0.0000	0.0000	0.0000	0.0000	0.0000	0.0000	0.0000	0.0000		0.0000	0.0000	0.0000			0.0000
Worker	0.0752	0.0940	1.1700	2.5500e-003	0.2012	1.6800e-003	0.2029	0.0534	1.5500e-003	0.0549		214.1025	214.1025	0.0110			214.3332
Total	0.0752	0.0940	1.1700	2.5500e-003	0.2012	1.6800e-003	0.2029	0.0534	1.5500e-003	0.0549		214.1025	214.1025	0.0110			214.3332

Mitigated Construction On-Site

	ROG	NOx	CO	SO2	Fugitive PM10	Exhaust PM10	PM10 Total	Fugitive PM2.5	Exhaust PM2.5	PM2.5 Total	Bio- CO2	NBio- CO2	Total CO2	CH4	N2O	CO2e	
Category	lb/day										lb/day						
Fugitive Dust					8.1298	0.0000	8.1298	4.4688	0.0000	4.4688			0.0000				0.0000
Off-Road	0.9515	19.4584	23.4003	0.0391		0.9611	0.9611		0.9611	0.9611	0.0000	4,065.0053	4,065.0053	1.2262			4,090.7544
Total	0.9515	19.4584	23.4003	0.0391	8.1298	0.9611	9.0909	4.4688	0.9611	5.4299	0.0000	4,065.0053	4,065.0053	1.2262			4,090.7544

3.2 Site Preparation - 2016

Mitigated Construction Off-Site

	ROG	NOx	CO	SO2	Fugitive PM10	Exhaust PM10	PM10 Total	Fugitive PM2.5	Exhaust PM2.5	PM2.5 Total	Bio- CO2	NBio- CO2	Total CO2	CH4	N2O	CO2e	
Category	lb/day										lb/day						
Hauling	0.0000	0.0000	0.0000	0.0000	0.0000	0.0000	0.0000	0.0000	0.0000	0.0000		0.0000	0.0000	0.0000			0.0000
Vendor	0.0000	0.0000	0.0000	0.0000	0.0000	0.0000	0.0000	0.0000	0.0000	0.0000		0.0000	0.0000	0.0000			0.0000
Worker	0.0752	0.0940	1.1700	2.5500e-003	0.2012	1.6800e-003	0.2029	0.0534	1.5500e-003	0.0549		214.1025	214.1025	0.0110			214.3332
Total	0.0752	0.0940	1.1700	2.5500e-003	0.2012	1.6800e-003	0.2029	0.0534	1.5500e-003	0.0549		214.1025	214.1025	0.0110			214.3332

3.3 Grading - 2016

Unmitigated Construction On-Site

	ROG	NOx	CO	SO2	Fugitive PM10	Exhaust PM10	PM10 Total	Fugitive PM2.5	Exhaust PM2.5	PM2.5 Total	Bio- CO2	NBio- CO2	Total CO2	CH4	N2O	CO2e	
Category	lb/day										lb/day						
Fugitive Dust					6.0754	0.0000	6.0754	3.3167	0.0000	3.3167			0.0000				0.0000
Off-Road	3.6669	38.4466	26.0787	0.0298		2.1984	2.1984		2.0225	2.0225		3,093.7889	3,093.7889	0.9332			3,113.3860
Total	3.6669	38.4466	26.0787	0.0298	6.0754	2.1984	8.2738	3.3167	2.0225	5.3392		3,093.7889	3,093.7889	0.9332			3,113.3860

3.3 Grading - 2016

Unmitigated Construction Off-Site

	ROG	NOx	CO	SO2	Fugitive PM10	Exhaust PM10	PM10 Total	Fugitive PM2.5	Exhaust PM2.5	PM2.5 Total	Bio- CO2	NBio- CO2	Total CO2	CH4	N2O	CO2e
Category	lb/day										lb/day					
Hauling	0.2986	4.7846	3.3842	0.0129	0.3041	0.0760	0.3801	0.0833	0.0699	0.1532		1,297.1376	1,297.1376	9.2200e-003		1,297.3312
Vendor	0.0000	0.0000	0.0000	0.0000	0.0000	0.0000	0.0000	0.0000	0.0000	0.0000		0.0000	0.0000	0.0000		0.0000
Worker	0.0627	0.0783	0.9750	2.1200e-003	0.1677	1.4000e-003	0.1691	0.0445	1.2900e-003	0.0458		178.4188	178.4188	9.1500e-003		178.6110
Total	0.3612	4.8629	4.3592	0.0150	0.4718	0.0774	0.5492	0.1278	0.0712	0.1989		1,475.5563	1,475.5563	0.0184		1,475.9421

Mitigated Construction On-Site

	ROG	NOx	CO	SO2	Fugitive PM10	Exhaust PM10	PM10 Total	Fugitive PM2.5	Exhaust PM2.5	PM2.5 Total	Bio- CO2	NBio- CO2	Total CO2	CH4	N2O	CO2e
Category	lb/day										lb/day					
Fugitive Dust					2.7339	0.0000	2.7339	1.4925	0.0000	1.4925			0.0000			0.0000
Off-Road	0.7250	14.8148	20.3762	0.0298		0.7854	0.7854		0.7854	0.7854	0.0000	3,093.7889	3,093.7889	0.9332		3,113.3860
Total	0.7250	14.8148	20.3762	0.0298	2.7339	0.7854	3.5194	1.4925	0.7854	2.2779	0.0000	3,093.7889	3,093.7889	0.9332		3,113.3860

3.3 Grading - 2016

Mitigated Construction Off-Site

	ROG	NOx	CO	SO2	Fugitive PM10	Exhaust PM10	PM10 Total	Fugitive PM2.5	Exhaust PM2.5	PM2.5 Total	Bio- CO2	NBio- CO2	Total CO2	CH4	N2O	CO2e
Category	lb/day										lb/day					
Hauling	0.2986	4.7846	3.3842	0.0129	0.3041	0.0760	0.3801	0.0833	0.0699	0.1532		1,297.1376	1,297.1376	9.2200e-003		1,297.3312
Vendor	0.0000	0.0000	0.0000	0.0000	0.0000	0.0000	0.0000	0.0000	0.0000	0.0000		0.0000	0.0000	0.0000		0.0000
Worker	0.0627	0.0783	0.9750	2.1200e-003	0.1677	1.4000e-003	0.1691	0.0445	1.2900e-003	0.0458		178.4188	178.4188	9.1500e-003		178.6110
Total	0.3612	4.8629	4.3592	0.0150	0.4718	0.0774	0.5492	0.1278	0.0712	0.1989		1,475.5563	1,475.5563	0.0184		1,475.9421

3.4 Building Construction - 2016

Unmitigated Construction On-Site

	ROG	NOx	CO	SO2	Fugitive PM10	Exhaust PM10	PM10 Total	Fugitive PM2.5	Exhaust PM2.5	PM2.5 Total	Bio- CO2	NBio- CO2	Total CO2	CH4	N2O	CO2e
Category	lb/day										lb/day					
Off-Road	3.4062	28.5063	18.5066	0.0268		1.9674	1.9674		1.8485	1.8485		2,669.2864	2,669.2864	0.6620		2,683.1890
Total	3.4062	28.5063	18.5066	0.0268		1.9674	1.9674		1.8485	1.8485		2,669.2864	2,669.2864	0.6620		2,683.1890

3.4 Building Construction - 2016

Unmitigated Construction Off-Site

	ROG	NOx	CO	SO2	Fugitive PM10	Exhaust PM10	PM10 Total	Fugitive PM2.5	Exhaust PM2.5	PM2.5 Total	Bio- CO2	NBio- CO2	Total CO2	CH4	N2O	CO2e	
Category	lb/day										lb/day						
Hauling	0.0000	0.0000	0.0000	0.0000	0.0000	0.0000	0.0000	0.0000	0.0000	0.0000		0.0000	0.0000	0.0000			0.0000
Vendor	0.1832	1.9001	2.1910	4.7800e-003	0.1375	0.0313	0.1688	0.0392	0.0288	0.0679		479.6636	479.6636	3.4200e-003			479.7355
Worker	0.2340	0.2925	3.6401	7.9300e-003	0.6260	5.2300e-003	0.6312	0.1660	4.8100e-003	0.1708		666.0967	666.0967	0.0342			666.8144
Total	0.4171	2.1926	5.8311	0.0127	0.7635	0.0365	0.8000	0.2052	0.0336	0.2387		1,145.7603	1,145.7603	0.0376			1,146.5499

Mitigated Construction On-Site

	ROG	NOx	CO	SO2	Fugitive PM10	Exhaust PM10	PM10 Total	Fugitive PM2.5	Exhaust PM2.5	PM2.5 Total	Bio- CO2	NBio- CO2	Total CO2	CH4	N2O	CO2e	
Category	lb/day										lb/day						
Off-Road	0.6712	14.1741	17.8156	0.0268		0.9016	0.9016		0.9016	0.9016	0.0000	2,669.2864	2,669.2864	0.6620			2,683.1890
Total	0.6712	14.1741	17.8156	0.0268		0.9016	0.9016		0.9016	0.9016	0.0000	2,669.2864	2,669.2864	0.6620			2,683.1890

3.4 Building Construction - 2016

Mitigated Construction Off-Site

	ROG	NOx	CO	SO2	Fugitive PM10	Exhaust PM10	PM10 Total	Fugitive PM2.5	Exhaust PM2.5	PM2.5 Total	Bio- CO2	NBio- CO2	Total CO2	CH4	N2O	CO2e	
Category	lb/day										lb/day						
Hauling	0.0000	0.0000	0.0000	0.0000	0.0000	0.0000	0.0000	0.0000	0.0000	0.0000		0.0000	0.0000	0.0000			0.0000
Vendor	0.1832	1.9001	2.1910	4.7800e-003	0.1375	0.0313	0.1688	0.0392	0.0288	0.0679		479.6636	479.6636	3.4200e-003			479.7355
Worker	0.2340	0.2925	3.6401	7.9300e-003	0.6260	5.2300e-003	0.6312	0.1660	4.8100e-003	0.1708		666.0967	666.0967	0.0342			666.8144
Total	0.4171	2.1926	5.8311	0.0127	0.7635	0.0365	0.8000	0.2052	0.0336	0.2387		1,145.7603	1,145.7603	0.0376			1,146.5499

3.4 Building Construction - 2017

Unmitigated Construction On-Site

	ROG	NOx	CO	SO2	Fugitive PM10	Exhaust PM10	PM10 Total	Fugitive PM2.5	Exhaust PM2.5	PM2.5 Total	Bio- CO2	NBio- CO2	Total CO2	CH4	N2O	CO2e	
Category	lb/day										lb/day						
Off-Road	3.1024	26.4057	18.1291	0.0268		1.7812	1.7812		1.6730	1.6730		2,639.8053	2,639.8053	0.6497			2,653.4490
Total	3.1024	26.4057	18.1291	0.0268		1.7812	1.7812		1.6730	1.6730		2,639.8053	2,639.8053	0.6497			2,653.4490

3.4 Building Construction - 2017

Unmitigated Construction Off-Site

	ROG	NOx	CO	SO2	Fugitive PM10	Exhaust PM10	PM10 Total	Fugitive PM2.5	Exhaust PM2.5	PM2.5 Total	Bio- CO2	NBio- CO2	Total CO2	CH4	N2O	CO2e	
Category	lb/day										lb/day						
Hauling	0.0000	0.0000	0.0000	0.0000	0.0000	0.0000	0.0000	0.0000	0.0000	0.0000		0.0000	0.0000	0.0000			0.0000
Vendor	0.1679	1.7289	2.0605	4.7800e-003	0.1375	0.0279	0.1654	0.0392	0.0257	0.0648		471.8944	471.8944	3.3100e-003			471.9639
Worker	0.2102	0.2641	3.2926	7.9300e-003	0.6260	5.0300e-003	0.6310	0.1660	4.6400e-003	0.1707		640.6028	640.6028	0.0315			641.2650
Total	0.3781	1.9930	5.3530	0.0127	0.7635	0.0329	0.7964	0.2052	0.0303	0.2355		1,112.4972	1,112.4972	0.0348			1,113.2289

Mitigated Construction On-Site

	ROG	NOx	CO	SO2	Fugitive PM10	Exhaust PM10	PM10 Total	Fugitive PM2.5	Exhaust PM2.5	PM2.5 Total	Bio- CO2	NBio- CO2	Total CO2	CH4	N2O	CO2e	
Category	lb/day										lb/day						
Off-Road	0.6712	14.1741	17.8156	0.0268		0.9016	0.9016		0.9016	0.9016	0.0000	2,639.8053	2,639.8053	0.6497			2,653.4490
Total	0.6712	14.1741	17.8156	0.0268		0.9016	0.9016		0.9016	0.9016	0.0000	2,639.8053	2,639.8053	0.6497			2,653.4490

3.4 Building Construction - 2017

Mitigated Construction Off-Site

	ROG	NOx	CO	SO2	Fugitive PM10	Exhaust PM10	PM10 Total	Fugitive PM2.5	Exhaust PM2.5	PM2.5 Total	Bio- CO2	NBio- CO2	Total CO2	CH4	N2O	CO2e
Category	lb/day										lb/day					
Hauling	0.0000	0.0000	0.0000	0.0000	0.0000	0.0000	0.0000	0.0000	0.0000	0.0000		0.0000	0.0000	0.0000		0.0000
Vendor	0.1679	1.7289	2.0605	4.7800e-003	0.1375	0.0279	0.1654	0.0392	0.0257	0.0648		471.8944	471.8944	3.3100e-003		471.9639
Worker	0.2102	0.2641	3.2926	7.9300e-003	0.6260	5.0300e-003	0.6310	0.1660	4.6400e-003	0.1707		640.6028	640.6028	0.0315		641.2650
Total	0.3781	1.9930	5.3530	0.0127	0.7635	0.0329	0.7964	0.2052	0.0303	0.2355		1,112.4972	1,112.4972	0.0348		1,113.2289

3.5 Trenching and Utilities - 2016

Unmitigated Construction Off-Site

	ROG	NOx	CO	SO2	Fugitive PM10	Exhaust PM10	PM10 Total	Fugitive PM2.5	Exhaust PM2.5	PM2.5 Total	Bio- CO2	NBio- CO2	Total CO2	CH4	N2O	CO2e
Category	lb/day										lb/day					
Hauling					0.0000	0.0000	0.0000	0.0000	0.0000	0.0000			0.0000			0.0000
Vendor					0.0000	0.0000	0.0000	0.0000	0.0000	0.0000			0.0000			0.0000
Worker					0.0000	0.0000	0.0000	0.0000	0.0000	0.0000			0.0000			0.0000
Total					0.0000	0.0000	0.0000	0.0000	0.0000	0.0000			0.0000			0.0000

3.5 Trenching and Utilities - 2016

Mitigated Construction Off-Site

	ROG	NOx	CO	SO2	Fugitive PM10	Exhaust PM10	PM10 Total	Fugitive PM2.5	Exhaust PM2.5	PM2.5 Total	Bio- CO2	NBio- CO2	Total CO2	CH4	N2O	CO2e
Category	lb/day										lb/day					
Hauling					0.0000	0.0000	0.0000	0.0000	0.0000	0.0000			0.0000			0.0000
Vendor					0.0000	0.0000	0.0000	0.0000	0.0000	0.0000			0.0000			0.0000
Worker					0.0000	0.0000	0.0000	0.0000	0.0000	0.0000			0.0000			0.0000
Total					0.0000	0.0000	0.0000	0.0000	0.0000	0.0000			0.0000			0.0000

3.6 Architectural Coating - 2016

Unmitigated Construction On-Site

	ROG	NOx	CO	SO2	Fugitive PM10	Exhaust PM10	PM10 Total	Fugitive PM2.5	Exhaust PM2.5	PM2.5 Total	Bio- CO2	NBio- CO2	Total CO2	CH4	N2O	CO2e
Category	lb/day										lb/day					
Archit. Coating	10.2933					0.0000	0.0000		0.0000	0.0000			0.0000			0.0000
Off-Road	0.3685	2.3722	1.8839	2.9700e-003		0.1966	0.1966		0.1966	0.1966		281.4481	281.4481	0.0332		282.1449
Total	10.6617	2.3722	1.8839	2.9700e-003		0.1966	0.1966		0.1966	0.1966		281.4481	281.4481	0.0332		282.1449

3.6 Architectural Coating - 2016

Unmitigated Construction Off-Site

	ROG	NOx	CO	SO2	Fugitive PM10	Exhaust PM10	PM10 Total	Fugitive PM2.5	Exhaust PM2.5	PM2.5 Total	Bio- CO2	NBio- CO2	Total CO2	CH4	N2O	CO2e
Category	lb/day										lb/day					
Hauling	0.0000	0.0000	0.0000	0.0000	0.0000	0.0000	0.0000	0.0000	0.0000	0.0000		0.0000	0.0000	0.0000		0.0000
Vendor	0.0000	0.0000	0.0000	0.0000	0.0000	0.0000	0.0000	0.0000	0.0000	0.0000		0.0000	0.0000	0.0000		0.0000
Worker	0.0460	0.0575	0.7150	1.5600e-003	0.1230	1.0300e-003	0.1240	0.0326	9.4000e-004	0.0336		130.8404	130.8404	6.7100e-003		130.9814
Total	0.0460	0.0575	0.7150	1.5600e-003	0.1230	1.0300e-003	0.1240	0.0326	9.4000e-004	0.0336		130.8404	130.8404	6.7100e-003		130.9814

Mitigated Construction On-Site

	ROG	NOx	CO	SO2	Fugitive PM10	Exhaust PM10	PM10 Total	Fugitive PM2.5	Exhaust PM2.5	PM2.5 Total	Bio- CO2	NBio- CO2	Total CO2	CH4	N2O	CO2e
Category	lb/day										lb/day					
Archit. Coating	10.2933					0.0000	0.0000		0.0000	0.0000			0.0000			0.0000
Off-Road	0.0594	1.3570	1.8324	2.9700e-003		0.0951	0.0951		0.0951	0.0951	0.0000	281.4481	281.4481	0.0332		282.1449
Total	10.3527	1.3570	1.8324	2.9700e-003		0.0951	0.0951		0.0951	0.0951	0.0000	281.4481	281.4481	0.0332		282.1449

3.6 Architectural Coating - 2016

Mitigated Construction Off-Site

	ROG	NOx	CO	SO2	Fugitive PM10	Exhaust PM10	PM10 Total	Fugitive PM2.5	Exhaust PM2.5	PM2.5 Total	Bio- CO2	NBio- CO2	Total CO2	CH4	N2O	CO2e	
Category	lb/day										lb/day						
Hauling	0.0000	0.0000	0.0000	0.0000	0.0000	0.0000	0.0000	0.0000	0.0000	0.0000		0.0000	0.0000	0.0000			0.0000
Vendor	0.0000	0.0000	0.0000	0.0000	0.0000	0.0000	0.0000	0.0000	0.0000	0.0000		0.0000	0.0000	0.0000			0.0000
Worker	0.0460	0.0575	0.7150	1.5600e-003	0.1230	1.0300e-003	0.1240	0.0326	9.4000e-004	0.0336		130.8404	130.8404	6.7100e-003			130.9814
Total	0.0460	0.0575	0.7150	1.5600e-003	0.1230	1.0300e-003	0.1240	0.0326	9.4000e-004	0.0336		130.8404	130.8404	6.7100e-003			130.9814

3.6 Architectural Coating - 2017

Unmitigated Construction On-Site

	ROG	NOx	CO	SO2	Fugitive PM10	Exhaust PM10	PM10 Total	Fugitive PM2.5	Exhaust PM2.5	PM2.5 Total	Bio- CO2	NBio- CO2	Total CO2	CH4	N2O	CO2e	
Category	lb/day										lb/day						
Archit. Coating	10.2933					0.0000	0.0000		0.0000	0.0000			0.0000				0.0000
Off-Road	0.3323	2.1850	1.8681	2.9700e-003		0.1733	0.1733		0.1733	0.1733		281.4481	281.4481	0.0297			282.0721
Total	10.6256	2.1850	1.8681	2.9700e-003		0.1733	0.1733		0.1733	0.1733		281.4481	281.4481	0.0297			282.0721

3.6 Architectural Coating - 2017

Unmitigated Construction Off-Site

	ROG	NOx	CO	SO2	Fugitive PM10	Exhaust PM10	PM10 Total	Fugitive PM2.5	Exhaust PM2.5	PM2.5 Total	Bio- CO2	NBio- CO2	Total CO2	CH4	N2O	CO2e
Category	lb/day										lb/day					
Hauling	0.0000	0.0000	0.0000	0.0000	0.0000	0.0000	0.0000	0.0000	0.0000	0.0000		0.0000	0.0000	0.0000		0.0000
Vendor	0.0000	0.0000	0.0000	0.0000	0.0000	0.0000	0.0000	0.0000	0.0000	0.0000		0.0000	0.0000	0.0000		0.0000
Worker	0.0413	0.0519	0.6468	1.5600e-003	0.1230	9.9000e-004	0.1239	0.0326	9.1000e-004	0.0335		125.8327	125.8327	6.1900e-003		125.9628
Total	0.0413	0.0519	0.6468	1.5600e-003	0.1230	9.9000e-004	0.1239	0.0326	9.1000e-004	0.0335		125.8327	125.8327	6.1900e-003		125.9628

Mitigated Construction On-Site

	ROG	NOx	CO	SO2	Fugitive PM10	Exhaust PM10	PM10 Total	Fugitive PM2.5	Exhaust PM2.5	PM2.5 Total	Bio- CO2	NBio- CO2	Total CO2	CH4	N2O	CO2e
Category	lb/day										lb/day					
Archit. Coating	10.2933					0.0000	0.0000		0.0000	0.0000			0.0000			0.0000
Off-Road	0.0594	1.3570	1.8324	2.9700e-003		0.0951	0.0951		0.0951	0.0951	0.0000	281.4481	281.4481	0.0297		282.0721
Total	10.3527	1.3570	1.8324	2.9700e-003		0.0951	0.0951		0.0951	0.0951	0.0000	281.4481	281.4481	0.0297		282.0721

3.6 Architectural Coating - 2017

Mitigated Construction Off-Site

	ROG	NOx	CO	SO2	Fugitive PM10	Exhaust PM10	PM10 Total	Fugitive PM2.5	Exhaust PM2.5	PM2.5 Total	Bio- CO2	NBio- CO2	Total CO2	CH4	N2O	CO2e	
Category	lb/day										lb/day						
Hauling	0.0000	0.0000	0.0000	0.0000	0.0000	0.0000	0.0000	0.0000	0.0000	0.0000		0.0000	0.0000	0.0000			0.0000
Vendor	0.0000	0.0000	0.0000	0.0000	0.0000	0.0000	0.0000	0.0000	0.0000	0.0000		0.0000	0.0000	0.0000			0.0000
Worker	0.0413	0.0519	0.6468	1.5600e-003	0.1230	9.9000e-004	0.1239	0.0326	9.1000e-004	0.0335		125.8327	125.8327	6.1900e-003			125.9628
Total	0.0413	0.0519	0.6468	1.5600e-003	0.1230	9.9000e-004	0.1239	0.0326	9.1000e-004	0.0335		125.8327	125.8327	6.1900e-003			125.9628

3.7 Paving - 2017

Unmitigated Construction On-Site

	ROG	NOx	CO	SO2	Fugitive PM10	Exhaust PM10	PM10 Total	Fugitive PM2.5	Exhaust PM2.5	PM2.5 Total	Bio- CO2	NBio- CO2	Total CO2	CH4	N2O	CO2e	
Category	lb/day										lb/day						
Off-Road	1.9074	20.2964	14.7270	0.0223		1.1384	1.1384		1.0473	1.0473		2,281.0588	2,281.0588	0.6989			2,295.7360
Paving	0.1697					0.0000	0.0000		0.0000	0.0000			0.0000				0.0000
Total	2.0771	20.2964	14.7270	0.0223		1.1384	1.1384		1.0473	1.0473		2,281.0588	2,281.0588	0.6989			2,295.7360

3.7 Paving - 2017

Unmitigated Construction Off-Site

	ROG	NOx	CO	SO2	Fugitive PM10	Exhaust PM10	PM10 Total	Fugitive PM2.5	Exhaust PM2.5	PM2.5 Total	Bio- CO2	NBio- CO2	Total CO2	CH4	N2O	CO2e	
Category	lb/day										lb/day						
Hauling	0.0000	0.0000	0.0000	0.0000	0.0000	0.0000	0.0000	0.0000	0.0000	0.0000		0.0000	0.0000	0.0000			0.0000
Vendor	0.0000	0.0000	0.0000	0.0000	0.0000	0.0000	0.0000	0.0000	0.0000	0.0000		0.0000	0.0000	0.0000			0.0000
Worker	0.0563	0.0707	0.8819	2.1200e-003	0.1677	1.3500e-003	0.1690	0.0445	1.2400e-003	0.0457		171.5900	171.5900	8.4500e-003			171.7674
Total	0.0563	0.0707	0.8819	2.1200e-003	0.1677	1.3500e-003	0.1690	0.0445	1.2400e-003	0.0457		171.5900	171.5900	8.4500e-003			171.7674

Mitigated Construction On-Site

	ROG	NOx	CO	SO2	Fugitive PM10	Exhaust PM10	PM10 Total	Fugitive PM2.5	Exhaust PM2.5	PM2.5 Total	Bio- CO2	NBio- CO2	Total CO2	CH4	N2O	CO2e	
Category	lb/day										lb/day						
Off-Road	0.5490	11.0645	16.9276	0.0223		0.5982	0.5982		0.5982	0.5982	0.0000	2,281.0588	2,281.0588	0.6989			2,295.7360
Paving	0.1697					0.0000	0.0000		0.0000	0.0000			0.0000				0.0000
Total	0.7187	11.0645	16.9276	0.0223		0.5982	0.5982		0.5982	0.5982	0.0000	2,281.0588	2,281.0588	0.6989			2,295.7360

3.7 Paving - 2017

Mitigated Construction Off-Site

	ROG	NOx	CO	SO2	Fugitive PM10	Exhaust PM10	PM10 Total	Fugitive PM2.5	Exhaust PM2.5	PM2.5 Total	Bio- CO2	NBio- CO2	Total CO2	CH4	N2O	CO2e
Category	lb/day										lb/day					
Hauling	0.0000	0.0000	0.0000	0.0000	0.0000	0.0000	0.0000	0.0000	0.0000	0.0000		0.0000	0.0000	0.0000		0.0000
Vendor	0.0000	0.0000	0.0000	0.0000	0.0000	0.0000	0.0000	0.0000	0.0000	0.0000		0.0000	0.0000	0.0000		0.0000
Worker	0.0563	0.0707	0.8819	2.1200e-003	0.1677	1.3500e-003	0.1690	0.0445	1.2400e-003	0.0457		171.5900	171.5900	8.4500e-003		171.7674
Total	0.0563	0.0707	0.8819	2.1200e-003	0.1677	1.3500e-003	0.1690	0.0445	1.2400e-003	0.0457		171.5900	171.5900	8.4500e-003		171.7674

4.0 Operational Detail - Mobile

4.1 Mitigation Measures Mobile

	ROG	NOx	CO	SO2	Fugitive PM10	Exhaust PM10	PM10 Total	Fugitive PM2.5	Exhaust PM2.5	PM2.5 Total	Bio- CO2	NBio- CO2	Total CO2	CH4	N2O	CO2e
Category	lb/day										lb/day					
Mitigated	3.0716	7.4373	30.8256	0.0797	5.2643	0.1107	5.3750	1.4066	0.1020	1.5086		6,575.0266	6,575.0266	0.2433		6,580.1351
Unmitigated	3.0716	7.4373	30.8256	0.0797	5.2643	0.1107	5.3750	1.4066	0.1020	1.5086		6,575.0266	6,575.0266	0.2433		6,580.1351

4.2 Trip Summary Information

Land Use	Average Daily Trip Rate			Unmitigated	Mitigated
	Weekday	Saturday	Sunday	Annual VMT	Annual VMT
Hotel	1,037.59	1,040.13	755.65	2,380,625	2,380,625
Parking Lot	0.00	0.00	0.00		
Total	1,037.59	1,040.13	755.65	2,380,625	2,380,625

4.3 Trip Type Information

Land Use	Miles			Trip %			Trip Purpose %		
	H-W or C-W	H-S or C-C	H-O or C-NW	H-W or C-W	H-S or C-C	H-O or C-NW	Primary	Diverted	Pass-by
Hotel	16.60	8.40	6.90	19.40	61.60	19.00	58	38	4
Parking Lot	16.60	8.40	6.90	0.00	0.00	0.00	0	0	0

LDA	LDT1	LDT2	MDV	LHD1	LHD2	MHD	HHD	OBUS	UBUS	MCY	SBUS	MH
0.511172	0.060004	0.180590	0.138995	0.042398	0.006681	0.016070	0.032568	0.001938	0.002493	0.004370	0.000586	0.002135

5.0 Energy Detail

4.4 Fleet Mix

Historical Energy Use: N

5.1 Mitigation Measures Energy

	ROG	NOx	CO	SO2	Fugitive PM10	Exhaust PM10	PM10 Total	Fugitive PM2.5	Exhaust PM2.5	PM2.5 Total	Bio- CO2	NBio- CO2	Total CO2	CH4	N2O	CO2e
Category	lb/day										lb/day					
NaturalGas Mitigated	0.0539	0.4903	0.4118	2.9400e-003		0.0373	0.0373		0.0373	0.0373		588.3349	588.3349	0.0113	0.0108	591.9154
NaturalGas Unmitigated	0.0539	0.4903	0.4118	2.9400e-003		0.0373	0.0373		0.0373	0.0373		588.3349	588.3349	0.0113	0.0108	591.9154

5.2 Energy by Land Use - NaturalGas

Unmitigated

	NaturalGas Use	ROG	NOx	CO	SO2	Fugitive PM10	Exhaust PM10	PM10 Total	Fugitive PM2.5	Exhaust PM2.5	PM2.5 Total	Bio- CO2	NBio- CO2	Total CO2	CH4	N2O	CO2e
Land Use	kBTU/yr	lb/day										lb/day					
Hotel	5000.85	0.0539	0.4903	0.4118	2.9400e-003		0.0373	0.0373		0.0373	0.0373		588.3349	588.3349	0.0113	0.0108	591.9154
Parking Lot	0	0.0000	0.0000	0.0000	0.0000		0.0000	0.0000		0.0000	0.0000		0.0000	0.0000	0.0000	0.0000	0.0000
Total		0.0539	0.4903	0.4118	2.9400e-003		0.0373	0.0373		0.0373	0.0373		588.3349	588.3349	0.0113	0.0108	591.9154

5.2 Energy by Land Use - NaturalGas

Mitigated

	NaturalGas Use	ROG	NOx	CO	SO2	Fugitive PM10	Exhaust PM10	PM10 Total	Fugitive PM2.5	Exhaust PM2.5	PM2.5 Total	Bio- CO2	NBio- CO2	Total CO2	CH4	N2O	CO2e	
Land Use	kBTU/yr	lb/day										lb/day						
Parking Lot	0	0.0000	0.0000	0.0000	0.0000		0.0000	0.0000		0.0000	0.0000		0.0000	0.0000	0.0000	0.0000	0.0000	0.0000
Hotel	5.00085	0.0539	0.4903	0.4118	2.9400e-003		0.0373	0.0373		0.0373	0.0373		588.3349	588.3349	0.0113	0.0108	591.9154	
Total		0.0539	0.4903	0.4118	2.9400e-003		0.0373	0.0373		0.0373	0.0373		588.3349	588.3349	0.0113	0.0108	591.9154	

6.0 Area Detail

6.1 Mitigation Measures Area

Use Low VOC Paint - Non-Residential Interior

Use Low VOC Paint - Non-Residential Exterior

Use only Natural Gas Hearths

	ROG	NOx	CO	SO2	Fugitive PM10	Exhaust PM10	PM10 Total	Fugitive PM2.5	Exhaust PM2.5	PM2.5 Total	Bio- CO2	NBio- CO2	Total CO2	CH4	N2O	CO2e
Category	lb/day										lb/day					
Mitigated	2.9280	2.7000e-004	0.0288	0.0000		1.0000e-004	1.0000e-004		1.0000e-004	1.0000e-004		0.0608	0.0608	1.7000e-004		0.0644
Unmitigated	3.0704	2.7000e-004	0.0288	0.0000		1.0000e-004	1.0000e-004		1.0000e-004	1.0000e-004		0.0608	0.0608	1.7000e-004		0.0644

6.2 Area by SubCategory

Unmitigated

	ROG	NOx	CO	SO2	Fugitive PM10	Exhaust PM10	PM10 Total	Fugitive PM2.5	Exhaust PM2.5	PM2.5 Total	Bio- CO2	NBio- CO2	Total CO2	CH4	N2O	CO2e
SubCategory	lb/day										lb/day					
Architectural Coating	0.4272					0.0000	0.0000		0.0000	0.0000			0.0000			0.0000
Consumer Products	2.6404					0.0000	0.0000		0.0000	0.0000			0.0000			0.0000
Landscaping	2.7500e-003	2.7000e-004	0.0288	0.0000		1.0000e-004	1.0000e-004		1.0000e-004	1.0000e-004		0.0608	0.0608	1.7000e-004		0.0644
Total	3.0704	2.7000e-004	0.0288	0.0000		1.0000e-004	1.0000e-004		1.0000e-004	1.0000e-004		0.0608	0.0608	1.7000e-004		0.0644

6.2 Area by SubCategory

Mitigated

	ROG	NOx	CO	SO2	Fugitive PM10	Exhaust PM10	PM10 Total	Fugitive PM2.5	Exhaust PM2.5	PM2.5 Total	Bio- CO2	NBio- CO2	Total CO2	CH4	N2O	CO2e
SubCategory	lb/day										lb/day					
Architectural Coating	0.2848					0.0000	0.0000		0.0000	0.0000			0.0000			0.0000
Consumer Products	2.6404					0.0000	0.0000		0.0000	0.0000			0.0000			0.0000
Landscaping	2.7500e-003	2.7000e-004	0.0288	0.0000		1.0000e-004	1.0000e-004		1.0000e-004	1.0000e-004		0.0608	0.0608	1.7000e-004		0.0644
Total	2.9280	2.7000e-004	0.0288	0.0000		1.0000e-004	1.0000e-004		1.0000e-004	1.0000e-004		0.0608	0.0608	1.7000e-004		0.0644

7.0 Water Detail

7.1 Mitigation Measures Water

8.0 Waste Detail

8.1 Mitigation Measures Waste

9.0 Operational Offroad

Equipment Type	Number	Hours/Day	Days/Year	Horse Power	Load Factor	Fuel Type
----------------	--------	-----------	-----------	-------------	-------------	-----------

10.0 Vegetation

Rondell Oasis Hotel Project
South Coast AQMD Air District, Winter

1.0 Project Characteristics

1.1 Land Usage

Land Uses	Size	Metric	Lot Acreage	Floor Surface Area	Population
Parking Lot	151.00	Space	1.36	60,400.00	0
Hotel	127.00	Room	3.64	72,954.00	0

1.2 Other Project Characteristics

Urbanization	Urban	Wind Speed (m/s)	2.2	Precipitation Freq (Days)	31
Climate Zone	9			Operational Year	2018
Utility Company	Southern California Edison				
CO2 Intensity (lb/MWhr)	630.89	CH4 Intensity (lb/MWhr)	0.029	N2O Intensity (lb/MWhr)	0.006

1.3 User Entered Comments & Non-Default Data

Project Characteristics - Operational year would be 2017, however, for the purposes of CalEEMod, the operational year input must be a year after all construction ends.

Land Use - Square feet of total building area from Nadel Residential & Commercial Inc., Site Plan, 2/13/2015. Project site approximately 5 acres.

Construction Phase - Applicant provided construction schedule.

Grading - Export from applicant provided grading quantities. Construction would occur on approximately 3.5 acres of the project site.

Architectural Coating - Use of low-VOC paint (150 g/L for nonflat coatings) as required by SCAQMD Rule 1113.

Vehicle Trips - Default vehicle trip rates consistent with Traffic Impact Analysis prepared by Overland Traffic Consultants, Inc. (December 2014).

Woodstoves - Project does not include woodstoves or wood burning fireplaces.

Area Coating - Use of low-VOC paint (150 g/L for nonflat coatings) as required by SCAQMD Rule 1113.

Energy Use -

Construction Off-road Equipment Mitigation - Compliance with SCAQMD Fugitive Dust Rule 403. Assumes that equipment used would comply with current EPA and ARB Tier 3 standards for nonroad diesel engines.

Area Mitigation - Use of low-VOC paint (150 g/L for nonflat coatings) as required by SCAQMD Rule 1113. Project would include at most one natural gas hearth and no wood burning hearths or woodstoves.

Trips and VMT -

Table Name	Column Name	Default Value	New Value
tblArchitecturalCoating	EF_Nonresidential_Exterior	250.00	150.00
tblArchitecturalCoating	EF_Nonresidential_Interior	250.00	150.00
tblAreaCoating	Area_EF_Nonresidential_Exterior	250	150
tblAreaMitigation	UseLowVOCPaintNonresidentialInteriorValue	250	150
tblConstEquipMitigation	NumberOfEquipmentMitigated	0.00	1.00
tblConstEquipMitigation	NumberOfEquipmentMitigated	0.00	1.00
tblConstEquipMitigation	NumberOfEquipmentMitigated	0.00	1.00
tblConstEquipMitigation	NumberOfEquipmentMitigated	0.00	3.00
tblConstEquipMitigation	NumberOfEquipmentMitigated	0.00	1.00
tblConstEquipMitigation	NumberOfEquipmentMitigated	0.00	1.00
tblConstEquipMitigation	NumberOfEquipmentMitigated	0.00	2.00
tblConstEquipMitigation	NumberOfEquipmentMitigated	0.00	2.00
tblConstEquipMitigation	NumberOfEquipmentMitigated	0.00	2.00

tblConstEquipMitigation	NumberOfEquipmentMitigated	0.00	4.00
tblConstEquipMitigation	NumberOfEquipmentMitigated	0.00	10.00
tblConstEquipMitigation	NumberOfEquipmentMitigated	0.00	1.00
tblConstEquipMitigation	Tier	No Change	Tier 3
tblConstEquipMitigation	Tier	No Change	Tier 3
tblConstEquipMitigation	Tier	No Change	Tier 3
tblConstEquipMitigation	Tier	No Change	Tier 3
tblConstEquipMitigation	Tier	No Change	Tier 3
tblConstEquipMitigation	Tier	No Change	Tier 3
tblConstEquipMitigation	Tier	No Change	Tier 3
tblConstEquipMitigation	Tier	No Change	Tier 3
tblConstEquipMitigation	Tier	No Change	Tier 3
tblConstEquipMitigation	Tier	No Change	Tier 3
tblConstEquipMitigation	Tier	No Change	Tier 3
tblConstEquipMitigation	Tier	No Change	Tier 3
tblConstructionPhase	NumDays	18.00	101.00
tblConstructionPhase	NumDays	230.00	240.00
tblConstructionPhase	NumDays	8.00	99.00
tblConstructionPhase	NumDays	18.00	21.00
tblConstructionPhase	NumDays	5.00	42.00
tblConstructionPhase	PhaseEndDate	12/1/2016	2/13/2017
tblConstructionPhase	PhaseEndDate	8/15/2017	5/8/2017
tblConstructionPhase	PhaseEndDate	10/21/2016	9/13/2016
tblConstructionPhase	PhaseEndDate	3/14/2017	3/9/2017
tblConstructionPhase	PhaseEndDate	6/12/2017	7/13/2016
tblConstructionPhase	PhaseStartDate	7/14/2016	9/26/2016
tblConstructionPhase	PhaseStartDate	9/14/2016	6/7/2016
tblConstructionPhase	PhaseStartDate	6/7/2016	4/28/2016

tblConstructionPhase	PhaseStartDate	2/14/2017	2/9/2017
tblConstructionPhase	PhaseStartDate	5/9/2017	6/9/2016
tblGrading	AcresOfGrading	49.50	3.50
tblGrading	MaterialExported	0.00	13,820.00
tblLandUse	LandUseSquareFeet	184,404.00	72,954.00
tblLandUse	LotAcreage	4.23	3.64
tblProjectCharacteristics	OperationalYear	2014	2018

2.0 Emissions Summary

2.2 Overall Operational

Unmitigated Operational

	ROG	NOx	CO	SO2	Fugitive PM10	Exhaust PM10	PM10 Total	Fugitive PM2.5	Exhaust PM2.5	PM2.5 Total	Bio- CO2	NBio- CO2	Total CO2	CH4	N2O	CO2e
Category	lb/day										lb/day					
Area	3.0704	2.7000e-004	0.0288	0.0000		1.0000e-004	1.0000e-004		1.0000e-004	1.0000e-004		0.0608	0.0608	1.7000e-004		0.0644
Energy	0.0539	0.4903	0.4118	2.9400e-003		0.0373	0.0373		0.0373	0.0373		588.3349	588.3349	0.0113	0.0108	591.9154
Mobile	3.1824	7.7978	31.0625	0.0757	5.2643	0.1112	5.3756	1.4066	0.1025	1.5091		6,261.2531	6,261.2531	0.2436		6,266.3679
Total	6.3068	8.2884	31.5031	0.0787	5.2643	0.1486	5.4129	1.4066	0.1399	1.5465		6,849.6489	6,849.6489	0.2550	0.0108	6,858.3477

Mitigated Operational

	ROG	NOx	CO	SO2	Fugitive PM10	Exhaust PM10	PM10 Total	Fugitive PM2.5	Exhaust PM2.5	PM2.5 Total	Bio- CO2	NBio- CO2	Total CO2	CH4	N2O	CO2e
Category	lb/day										lb/day					
Area	2.9280	2.7000e-004	0.0288	0.0000		1.0000e-004	1.0000e-004		1.0000e-004	1.0000e-004		0.0608	0.0608	1.7000e-004		0.0644
Energy	0.0539	0.4903	0.4118	2.9400e-003		0.0373	0.0373		0.0373	0.0373		588.3349	588.3349	0.0113	0.0108	591.9154
Mobile	3.1824	7.7978	31.0625	0.0757	5.2643	0.1112	5.3756	1.4066	0.1025	1.5091		6,261.2531	6,261.2531	0.2436		6,266.3679
Total	6.1644	8.2884	31.5031	0.0787	5.2643	0.1486	5.4129	1.4066	0.1399	1.5465		6,849.6489	6,849.6489	0.2550	0.0108	6,858.3477

	ROG	NOx	CO	SO2	Fugitive PM10	Exhaust PM10	PM10 Total	Fugitive PM2.5	Exhaust PM2.5	PM2.5 Total	Bio- CO2	NBio-CO2	Total CO2	CH4	N2O	CO2e
Percent Reduction	2.26	0.00	0.00	0.00	0.00	0.00	0.00	0.00	0.00	0.00	0.00	0.00	0.00	0.00	0.00	0.00

3.0 Construction Detail

Construction Phase

Phase Number	Phase Name	Phase Type	Start Date	End Date	Num Days Week	Num Days	Phase Description
1	Site Preparation	Site Preparation	4/8/2016	6/6/2016	5	42	
2	Grading	Grading	4/28/2016	9/13/2016	5	99	
3	Building Construction	Building Construction	6/7/2016	5/8/2017	5	240	
4	Trenching and Utilities	Trenching	6/9/2016	7/13/2016	5	25	
5	Architectural Coating	Architectural Coating	9/26/2016	2/13/2017	5	101	
6	Paving	Paving	2/9/2017	3/9/2017	5	21	

Acres of Grading (Site Preparation Phase): 0

Acres of Grading (Grading Phase): 3.5

Acres of Paving: 0

Residential Indoor: 0; Residential Outdoor: 0; Non-Residential Indoor: 112,149; Non-Residential Outdoor: 37,383 (Architectural Coating – sqft)

OffRoad Equipment

Phase Name	Offroad Equipment Type	Amount	Usage Hours	Horse Power	Load Factor
Site Preparation	Rubber Tired Dozers	3	8.00	255	0.40
Site Preparation	Tractors/Loaders/Backhoes	4	8.00	97	0.37
Grading	Excavators	1	8.00	162	0.38
Grading	Graders	1	8.00	174	0.41
Grading	Rubber Tired Dozers	1	8.00	255	0.40
Grading	Tractors/Loaders/Backhoes	3	8.00	97	0.37
Building Construction	Cranes	1	7.00	226	0.29
Building Construction	Forklifts	3	8.00	89	0.20
Building Construction	Generator Sets	1	8.00	84	0.74
Building Construction	Tractors/Loaders/Backhoes	3	7.00	97	0.37
Building Construction	Welders	1	8.00	46	0.45
Architectural Coating	Air Compressors	1	6.00	78	0.48
Paving	Pavers	2	8.00	125	0.42
Paving	Paving Equipment	2	8.00	130	0.36
Paving	Rollers	2	8.00	80	0.38

Trips and VMT

Phase Name	Offroad Equipment Count	Worker Trip Number	Vendor Trip Number	Hauling Trip Number	Worker Trip Length	Vendor Trip Length	Hauling Trip Length	Worker Vehicle Class	Vendor Vehicle Class	Hauling Vehicle Class
Site Preparation	7	18.00	0.00	0.00	14.70	6.90	20.00	LD_Mix	HDT_Mix	HHDT
Grading	6	15.00	0.00	1,728.00	14.70	6.90	20.00	LD_Mix	HDT_Mix	HHDT
Building Construction	9	56.00	22.00	0.00	14.70	6.90	20.00	LD_Mix	HDT_Mix	HHDT
Trenching and Utilities				0.00	14.70	6.90				
Architectural Coating	1	11.00	0.00	0.00	14.70	6.90	20.00	LD_Mix	HDT_Mix	HHDT
Paving	6	15.00	0.00	0.00	14.70	6.90	20.00	LD_Mix	HDT_Mix	HHDT

3.1 Mitigation Measures Construction

Use Cleaner Engines for Construction Equipment

Water Exposed Area

Clean Paved Roads

3.2 Site Preparation - 2016

Unmitigated Construction On-Site

	ROG	NOx	CO	SO2	Fugitive PM10	Exhaust PM10	PM10 Total	Fugitive PM2.5	Exhaust PM2.5	PM2.5 Total	Bio- CO2	NBio- CO2	Total CO2	CH4	N2O	CO2e
Category	lb/day										lb/day					
Fugitive Dust					18.0663	0.0000	18.0663	9.9307	0.0000	9.9307			0.0000			0.0000
Off-Road	5.0771	54.6323	41.1053	0.0391		2.9387	2.9387		2.7036	2.7036		4,065.005 3	4,065.005 3	1.2262		4,090.754 4
Total	5.0771	54.6323	41.1053	0.0391	18.0663	2.9387	21.0049	9.9307	2.7036	12.6343		4,065.005 3	4,065.005 3	1.2262		4,090.754 4

3.2 Site Preparation - 2016

Unmitigated Construction Off-Site

	ROG	NOx	CO	SO2	Fugitive PM10	Exhaust PM10	PM10 Total	Fugitive PM2.5	Exhaust PM2.5	PM2.5 Total	Bio- CO2	NBio- CO2	Total CO2	CH4	N2O	CO2e
Category	lb/day										lb/day					
Hauling	0.0000	0.0000	0.0000	0.0000	0.0000	0.0000	0.0000	0.0000	0.0000	0.0000		0.0000	0.0000	0.0000		0.0000
Vendor	0.0000	0.0000	0.0000	0.0000	0.0000	0.0000	0.0000	0.0000	0.0000	0.0000		0.0000	0.0000	0.0000		0.0000
Worker	0.0768	0.1032	1.0780	2.3900e-003	0.2012	1.6800e-003	0.2029	0.0534	1.5500e-003	0.0549		200.8288	200.8288	0.0110		201.0594
Total	0.0768	0.1032	1.0780	2.3900e-003	0.2012	1.6800e-003	0.2029	0.0534	1.5500e-003	0.0549		200.8288	200.8288	0.0110		201.0594

Mitigated Construction On-Site

	ROG	NOx	CO	SO2	Fugitive PM10	Exhaust PM10	PM10 Total	Fugitive PM2.5	Exhaust PM2.5	PM2.5 Total	Bio- CO2	NBio- CO2	Total CO2	CH4	N2O	CO2e
Category	lb/day										lb/day					
Fugitive Dust					8.1298	0.0000	8.1298	4.4688	0.0000	4.4688			0.0000			0.0000
Off-Road	0.9515	19.4584	23.4003	0.0391		0.9611	0.9611		0.9611	0.9611	0.0000	4,065.0053	4,065.0053	1.2262		4,090.7544
Total	0.9515	19.4584	23.4003	0.0391	8.1298	0.9611	9.0909	4.4688	0.9611	5.4299	0.0000	4,065.0053	4,065.0053	1.2262		4,090.7544

3.2 Site Preparation - 2016

Mitigated Construction Off-Site

	ROG	NOx	CO	SO2	Fugitive PM10	Exhaust PM10	PM10 Total	Fugitive PM2.5	Exhaust PM2.5	PM2.5 Total	Bio- CO2	NBio- CO2	Total CO2	CH4	N2O	CO2e	
Category	lb/day										lb/day						
Hauling	0.0000	0.0000	0.0000	0.0000	0.0000	0.0000	0.0000	0.0000	0.0000	0.0000		0.0000	0.0000	0.0000			0.0000
Vendor	0.0000	0.0000	0.0000	0.0000	0.0000	0.0000	0.0000	0.0000	0.0000	0.0000		0.0000	0.0000	0.0000			0.0000
Worker	0.0768	0.1032	1.0780	2.3900e-003	0.2012	1.6800e-003	0.2029	0.0534	1.5500e-003	0.0549		200.8288	200.8288	0.0110			201.0594
Total	0.0768	0.1032	1.0780	2.3900e-003	0.2012	1.6800e-003	0.2029	0.0534	1.5500e-003	0.0549		200.8288	200.8288	0.0110			201.0594

3.3 Grading - 2016

Unmitigated Construction On-Site

	ROG	NOx	CO	SO2	Fugitive PM10	Exhaust PM10	PM10 Total	Fugitive PM2.5	Exhaust PM2.5	PM2.5 Total	Bio- CO2	NBio- CO2	Total CO2	CH4	N2O	CO2e	
Category	lb/day										lb/day						
Fugitive Dust					6.0754	0.0000	6.0754	3.3167	0.0000	3.3167			0.0000				0.0000
Off-Road	3.6669	38.4466	26.0787	0.0298		2.1984	2.1984		2.0225	2.0225		3,093.7889	3,093.7889	0.9332			3,113.3860
Total	3.6669	38.4466	26.0787	0.0298	6.0754	2.1984	8.2738	3.3167	2.0225	5.3392		3,093.7889	3,093.7889	0.9332			3,113.3860

3.3 Grading - 2016

Unmitigated Construction Off-Site

	ROG	NOx	CO	SO2	Fugitive PM10	Exhaust PM10	PM10 Total	Fugitive PM2.5	Exhaust PM2.5	PM2.5 Total	Bio- CO2	NBio- CO2	Total CO2	CH4	N2O	CO2e
Category	lb/day										lb/day					
Hauling	0.3154	4.9583	3.8795	0.0129	0.3041	0.0761	0.3803	0.0833	0.0700	0.1533		1,294.0533	1,294.0533	9.3400e-003		1,294.2495
Vendor	0.0000	0.0000	0.0000	0.0000	0.0000	0.0000	0.0000	0.0000	0.0000	0.0000		0.0000	0.0000	0.0000		0.0000
Worker	0.0640	0.0860	0.8984	1.9900e-003	0.1677	1.4000e-003	0.1691	0.0445	1.2900e-003	0.0458		167.3573	167.3573	9.1500e-003		167.5495
Total	0.3794	5.0443	4.7779	0.0148	0.4718	0.0775	0.5493	0.1278	0.0713	0.1991		1,461.4106	1,461.4106	0.0185		1,461.7990

Mitigated Construction On-Site

	ROG	NOx	CO	SO2	Fugitive PM10	Exhaust PM10	PM10 Total	Fugitive PM2.5	Exhaust PM2.5	PM2.5 Total	Bio- CO2	NBio- CO2	Total CO2	CH4	N2O	CO2e
Category	lb/day										lb/day					
Fugitive Dust					2.7339	0.0000	2.7339	1.4925	0.0000	1.4925			0.0000			0.0000
Off-Road	0.7250	14.8148	20.3762	0.0298		0.7854	0.7854		0.7854	0.7854	0.0000	3,093.7889	3,093.7889	0.9332		3,113.3860
Total	0.7250	14.8148	20.3762	0.0298	2.7339	0.7854	3.5194	1.4925	0.7854	2.2779	0.0000	3,093.7889	3,093.7889	0.9332		3,113.3860

3.3 Grading - 2016

Mitigated Construction Off-Site

	ROG	NOx	CO	SO2	Fugitive PM10	Exhaust PM10	PM10 Total	Fugitive PM2.5	Exhaust PM2.5	PM2.5 Total	Bio- CO2	NBio- CO2	Total CO2	CH4	N2O	CO2e
Category	lb/day										lb/day					
Hauling	0.3154	4.9583	3.8795	0.0129	0.3041	0.0761	0.3803	0.0833	0.0700	0.1533		1,294.0533	1,294.0533	9.3400e-003		1,294.2495
Vendor	0.0000	0.0000	0.0000	0.0000	0.0000	0.0000	0.0000	0.0000	0.0000	0.0000		0.0000	0.0000	0.0000		0.0000
Worker	0.0640	0.0860	0.8984	1.9900e-003	0.1677	1.4000e-003	0.1691	0.0445	1.2900e-003	0.0458		167.3573	167.3573	9.1500e-003		167.5495
Total	0.3794	5.0443	4.7779	0.0148	0.4718	0.0775	0.5493	0.1278	0.0713	0.1991		1,461.4106	1,461.4106	0.0185		1,461.7990

3.4 Building Construction - 2016

Unmitigated Construction On-Site

	ROG	NOx	CO	SO2	Fugitive PM10	Exhaust PM10	PM10 Total	Fugitive PM2.5	Exhaust PM2.5	PM2.5 Total	Bio- CO2	NBio- CO2	Total CO2	CH4	N2O	CO2e
Category	lb/day										lb/day					
Off-Road	3.4062	28.5063	18.5066	0.0268		1.9674	1.9674		1.8485	1.8485		2,669.2864	2,669.2864	0.6620		2,683.1890
Total	3.4062	28.5063	18.5066	0.0268		1.9674	1.9674		1.8485	1.8485		2,669.2864	2,669.2864	0.6620		2,683.1890

3.4 Building Construction - 2016

Unmitigated Construction Off-Site

	ROG	NOx	CO	SO2	Fugitive PM10	Exhaust PM10	PM10 Total	Fugitive PM2.5	Exhaust PM2.5	PM2.5 Total	Bio- CO2	NBio- CO2	Total CO2	CH4	N2O	CO2e	
Category	lb/day										lb/day						
Hauling	0.0000	0.0000	0.0000	0.0000	0.0000	0.0000	0.0000	0.0000	0.0000	0.0000		0.0000	0.0000	0.0000			0.0000
Vendor	0.2008	1.9480	2.6303	4.7500e-003	0.1375	0.0316	0.1691	0.0392	0.0291	0.0682		475.6409	475.6409	3.5300e-003			475.7150
Worker	0.2389	0.3211	3.3539	7.4300e-003	0.6260	5.2300e-003	0.6312	0.1660	4.8100e-003	0.1708		624.8005	624.8005	0.0342			625.5182
Total	0.4397	2.2691	5.9842	0.0122	0.7635	0.0368	0.8003	0.2052	0.0339	0.2390		1,100.4415	1,100.4415	0.0377			1,101.2332

Mitigated Construction On-Site

	ROG	NOx	CO	SO2	Fugitive PM10	Exhaust PM10	PM10 Total	Fugitive PM2.5	Exhaust PM2.5	PM2.5 Total	Bio- CO2	NBio- CO2	Total CO2	CH4	N2O	CO2e	
Category	lb/day										lb/day						
Off-Road	0.6712	14.1741	17.8156	0.0268		0.9016	0.9016		0.9016	0.9016	0.0000	2,669.2864	2,669.2864	0.6620			2,683.1890
Total	0.6712	14.1741	17.8156	0.0268		0.9016	0.9016		0.9016	0.9016	0.0000	2,669.2864	2,669.2864	0.6620			2,683.1890

3.4 Building Construction - 2016

Mitigated Construction Off-Site

	ROG	NOx	CO	SO2	Fugitive PM10	Exhaust PM10	PM10 Total	Fugitive PM2.5	Exhaust PM2.5	PM2.5 Total	Bio- CO2	NBio- CO2	Total CO2	CH4	N2O	CO2e
Category	lb/day										lb/day					
Hauling	0.0000	0.0000	0.0000	0.0000	0.0000	0.0000	0.0000	0.0000	0.0000	0.0000		0.0000	0.0000	0.0000		0.0000
Vendor	0.2008	1.9480	2.6303	4.7500e-003	0.1375	0.0316	0.1691	0.0392	0.0291	0.0682		475.6409	475.6409	3.5300e-003		475.7150
Worker	0.2389	0.3211	3.3539	7.4300e-003	0.6260	5.2300e-003	0.6312	0.1660	4.8100e-003	0.1708		624.8005	624.8005	0.0342		625.5182
Total	0.4397	2.2691	5.9842	0.0122	0.7635	0.0368	0.8003	0.2052	0.0339	0.2390		1,100.4415	1,100.4415	0.0377		1,101.2332

3.4 Building Construction - 2017

Unmitigated Construction On-Site

	ROG	NOx	CO	SO2	Fugitive PM10	Exhaust PM10	PM10 Total	Fugitive PM2.5	Exhaust PM2.5	PM2.5 Total	Bio- CO2	NBio- CO2	Total CO2	CH4	N2O	CO2e
Category	lb/day										lb/day					
Off-Road	3.1024	26.4057	18.1291	0.0268		1.7812	1.7812		1.6730	1.6730		2,639.8053	2,639.8053	0.6497		2,653.4490
Total	3.1024	26.4057	18.1291	0.0268		1.7812	1.7812		1.6730	1.6730		2,639.8053	2,639.8053	0.6497		2,653.4490

3.4 Building Construction - 2017

Unmitigated Construction Off-Site

	ROG	NOx	CO	SO2	Fugitive PM10	Exhaust PM10	PM10 Total	Fugitive PM2.5	Exhaust PM2.5	PM2.5 Total	Bio- CO2	NBio- CO2	Total CO2	CH4	N2O	CO2e	
Category	lb/day										lb/day						
Hauling	0.0000	0.0000	0.0000	0.0000	0.0000	0.0000	0.0000	0.0000	0.0000	0.0000		0.0000	0.0000	0.0000			0.0000
Vendor	0.1834	1.7715	2.4970	4.7400e-003	0.1375	0.0282	0.1657	0.0392	0.0259	0.0651		467.9272	467.9272	3.4100e-003			467.9988
Worker	0.2142	0.2898	3.0229	7.4300e-003	0.6260	5.0300e-003	0.6310	0.1660	4.6400e-003	0.1707		600.8021	600.8021	0.0315			601.4643
Total	0.3975	2.0613	5.5198	0.0122	0.7635	0.0332	0.7967	0.2052	0.0306	0.2357		1,068.7292	1,068.7292	0.0349			1,069.4631

Mitigated Construction On-Site

	ROG	NOx	CO	SO2	Fugitive PM10	Exhaust PM10	PM10 Total	Fugitive PM2.5	Exhaust PM2.5	PM2.5 Total	Bio- CO2	NBio- CO2	Total CO2	CH4	N2O	CO2e	
Category	lb/day										lb/day						
Off-Road	0.6712	14.1741	17.8156	0.0268		0.9016	0.9016		0.9016	0.9016	0.0000	2,639.8053	2,639.8053	0.6497			2,653.4490
Total	0.6712	14.1741	17.8156	0.0268		0.9016	0.9016		0.9016	0.9016	0.0000	2,639.8053	2,639.8053	0.6497			2,653.4490

3.4 Building Construction - 2017

Mitigated Construction Off-Site

	ROG	NOx	CO	SO2	Fugitive PM10	Exhaust PM10	PM10 Total	Fugitive PM2.5	Exhaust PM2.5	PM2.5 Total	Bio- CO2	NBio- CO2	Total CO2	CH4	N2O	CO2e	
Category	lb/day										lb/day						
Hauling	0.0000	0.0000	0.0000	0.0000	0.0000	0.0000	0.0000	0.0000	0.0000	0.0000		0.0000	0.0000	0.0000			0.0000
Vendor	0.1834	1.7715	2.4970	4.7400e-003	0.1375	0.0282	0.1657	0.0392	0.0259	0.0651		467.9272	467.9272	3.4100e-003			467.9988
Worker	0.2142	0.2898	3.0229	7.4300e-003	0.6260	5.0300e-003	0.6310	0.1660	4.6400e-003	0.1707		600.8021	600.8021	0.0315			601.4643
Total	0.3975	2.0613	5.5198	0.0122	0.7635	0.0332	0.7967	0.2052	0.0306	0.2357		1,068.7292	1,068.7292	0.0349			1,069.4631

3.5 Trenching and Utilities - 2016

Unmitigated Construction Off-Site

	ROG	NOx	CO	SO2	Fugitive PM10	Exhaust PM10	PM10 Total	Fugitive PM2.5	Exhaust PM2.5	PM2.5 Total	Bio- CO2	NBio- CO2	Total CO2	CH4	N2O	CO2e
Category	lb/day										lb/day					
Hauling					0.0000	0.0000	0.0000	0.0000	0.0000	0.0000			0.0000			0.0000
Vendor					0.0000	0.0000	0.0000	0.0000	0.0000	0.0000			0.0000			0.0000
Worker					0.0000	0.0000	0.0000	0.0000	0.0000	0.0000			0.0000			0.0000
Total					0.0000	0.0000	0.0000	0.0000	0.0000	0.0000			0.0000			0.0000

3.5 Trenching and Utilities - 2016

Mitigated Construction Off-Site

	ROG	NOx	CO	SO2	Fugitive PM10	Exhaust PM10	PM10 Total	Fugitive PM2.5	Exhaust PM2.5	PM2.5 Total	Bio- CO2	NBio- CO2	Total CO2	CH4	N2O	CO2e
Category	lb/day										lb/day					
Hauling					0.0000	0.0000	0.0000	0.0000	0.0000	0.0000			0.0000			0.0000
Vendor					0.0000	0.0000	0.0000	0.0000	0.0000	0.0000			0.0000			0.0000
Worker					0.0000	0.0000	0.0000	0.0000	0.0000	0.0000			0.0000			0.0000
Total					0.0000	0.0000	0.0000	0.0000	0.0000	0.0000			0.0000			0.0000

3.6 Architectural Coating - 2016

Unmitigated Construction On-Site

	ROG	NOx	CO	SO2	Fugitive PM10	Exhaust PM10	PM10 Total	Fugitive PM2.5	Exhaust PM2.5	PM2.5 Total	Bio- CO2	NBio- CO2	Total CO2	CH4	N2O	CO2e
Category	lb/day										lb/day					
Archit. Coating	10.2933					0.0000	0.0000		0.0000	0.0000			0.0000			0.0000
Off-Road	0.3685	2.3722	1.8839	2.9700e-003		0.1966	0.1966		0.1966	0.1966		281.4481	281.4481	0.0332		282.1449
Total	10.6617	2.3722	1.8839	2.9700e-003		0.1966	0.1966		0.1966	0.1966		281.4481	281.4481	0.0332		282.1449

3.6 Architectural Coating - 2016

Unmitigated Construction Off-Site

	ROG	NOx	CO	SO2	Fugitive PM10	Exhaust PM10	PM10 Total	Fugitive PM2.5	Exhaust PM2.5	PM2.5 Total	Bio- CO2	NBio- CO2	Total CO2	CH4	N2O	CO2e
Category	lb/day										lb/day					
Hauling	0.0000	0.0000	0.0000	0.0000	0.0000	0.0000	0.0000	0.0000	0.0000	0.0000		0.0000	0.0000	0.0000		0.0000
Vendor	0.0000	0.0000	0.0000	0.0000	0.0000	0.0000	0.0000	0.0000	0.0000	0.0000		0.0000	0.0000	0.0000		0.0000
Worker	0.0469	0.0631	0.6588	1.4600e-003	0.1230	1.0300e-003	0.1240	0.0326	9.4000e-004	0.0336		122.7287	122.7287	6.7100e-003		122.8697
Total	0.0469	0.0631	0.6588	1.4600e-003	0.1230	1.0300e-003	0.1240	0.0326	9.4000e-004	0.0336		122.7287	122.7287	6.7100e-003		122.8697

Mitigated Construction On-Site

	ROG	NOx	CO	SO2	Fugitive PM10	Exhaust PM10	PM10 Total	Fugitive PM2.5	Exhaust PM2.5	PM2.5 Total	Bio- CO2	NBio- CO2	Total CO2	CH4	N2O	CO2e
Category	lb/day										lb/day					
Archit. Coating	10.2933					0.0000	0.0000		0.0000	0.0000			0.0000			0.0000
Off-Road	0.0594	1.3570	1.8324	2.9700e-003		0.0951	0.0951		0.0951	0.0951	0.0000	281.4481	281.4481	0.0332		282.1449
Total	10.3527	1.3570	1.8324	2.9700e-003		0.0951	0.0951		0.0951	0.0951	0.0000	281.4481	281.4481	0.0332		282.1449

3.6 Architectural Coating - 2016

Mitigated Construction Off-Site

	ROG	NOx	CO	SO2	Fugitive PM10	Exhaust PM10	PM10 Total	Fugitive PM2.5	Exhaust PM2.5	PM2.5 Total	Bio- CO2	NBio- CO2	Total CO2	CH4	N2O	CO2e	
Category	lb/day										lb/day						
Hauling	0.0000	0.0000	0.0000	0.0000	0.0000	0.0000	0.0000	0.0000	0.0000	0.0000		0.0000	0.0000	0.0000			0.0000
Vendor	0.0000	0.0000	0.0000	0.0000	0.0000	0.0000	0.0000	0.0000	0.0000	0.0000		0.0000	0.0000	0.0000			0.0000
Worker	0.0469	0.0631	0.6588	1.4600e-003	0.1230	1.0300e-003	0.1240	0.0326	9.4000e-004	0.0336		122.7287	122.7287	6.7100e-003			122.8697
Total	0.0469	0.0631	0.6588	1.4600e-003	0.1230	1.0300e-003	0.1240	0.0326	9.4000e-004	0.0336		122.7287	122.7287	6.7100e-003			122.8697

3.6 Architectural Coating - 2017

Unmitigated Construction On-Site

	ROG	NOx	CO	SO2	Fugitive PM10	Exhaust PM10	PM10 Total	Fugitive PM2.5	Exhaust PM2.5	PM2.5 Total	Bio- CO2	NBio- CO2	Total CO2	CH4	N2O	CO2e	
Category	lb/day										lb/day						
Archit. Coating	10.2933					0.0000	0.0000		0.0000	0.0000			0.0000				0.0000
Off-Road	0.3323	2.1850	1.8681	2.9700e-003		0.1733	0.1733		0.1733	0.1733		281.4481	281.4481	0.0297			282.0721
Total	10.6256	2.1850	1.8681	2.9700e-003		0.1733	0.1733		0.1733	0.1733		281.4481	281.4481	0.0297			282.0721

3.6 Architectural Coating - 2017

Unmitigated Construction Off-Site

	ROG	NOx	CO	SO2	Fugitive PM10	Exhaust PM10	PM10 Total	Fugitive PM2.5	Exhaust PM2.5	PM2.5 Total	Bio- CO2	NBio- CO2	Total CO2	CH4	N2O	CO2e	
Category	lb/day										lb/day						
Hauling	0.0000	0.0000	0.0000	0.0000	0.0000	0.0000	0.0000	0.0000	0.0000	0.0000		0.0000	0.0000	0.0000			0.0000
Vendor	0.0000	0.0000	0.0000	0.0000	0.0000	0.0000	0.0000	0.0000	0.0000	0.0000		0.0000	0.0000	0.0000			0.0000
Worker	0.0421	0.0569	0.5938	1.4600e-003	0.1230	9.9000e-004	0.1239	0.0326	9.1000e-004	0.0335		118.0147	118.0147	6.1900e-003			118.1448
Total	0.0421	0.0569	0.5938	1.4600e-003	0.1230	9.9000e-004	0.1239	0.0326	9.1000e-004	0.0335		118.0147	118.0147	6.1900e-003			118.1448

Mitigated Construction On-Site

	ROG	NOx	CO	SO2	Fugitive PM10	Exhaust PM10	PM10 Total	Fugitive PM2.5	Exhaust PM2.5	PM2.5 Total	Bio- CO2	NBio- CO2	Total CO2	CH4	N2O	CO2e	
Category	lb/day										lb/day						
Archit. Coating	10.2933					0.0000	0.0000		0.0000	0.0000			0.0000				0.0000
Off-Road	0.0594	1.3570	1.8324	2.9700e-003		0.0951	0.0951		0.0951	0.0951	0.0000	281.4481	281.4481	0.0297			282.0721
Total	10.3527	1.3570	1.8324	2.9700e-003		0.0951	0.0951		0.0951	0.0951	0.0000	281.4481	281.4481	0.0297			282.0721

3.6 Architectural Coating - 2017

Mitigated Construction Off-Site

	ROG	NOx	CO	SO2	Fugitive PM10	Exhaust PM10	PM10 Total	Fugitive PM2.5	Exhaust PM2.5	PM2.5 Total	Bio- CO2	NBio- CO2	Total CO2	CH4	N2O	CO2e	
Category	lb/day										lb/day						
Hauling	0.0000	0.0000	0.0000	0.0000	0.0000	0.0000	0.0000	0.0000	0.0000	0.0000		0.0000	0.0000	0.0000			0.0000
Vendor	0.0000	0.0000	0.0000	0.0000	0.0000	0.0000	0.0000	0.0000	0.0000	0.0000		0.0000	0.0000	0.0000			0.0000
Worker	0.0421	0.0569	0.5938	1.4600e-003	0.1230	9.9000e-004	0.1239	0.0326	9.1000e-004	0.0335		118.0147	118.0147	6.1900e-003			118.1448
Total	0.0421	0.0569	0.5938	1.4600e-003	0.1230	9.9000e-004	0.1239	0.0326	9.1000e-004	0.0335		118.0147	118.0147	6.1900e-003			118.1448

3.7 Paving - 2017

Unmitigated Construction On-Site

	ROG	NOx	CO	SO2	Fugitive PM10	Exhaust PM10	PM10 Total	Fugitive PM2.5	Exhaust PM2.5	PM2.5 Total	Bio- CO2	NBio- CO2	Total CO2	CH4	N2O	CO2e	
Category	lb/day										lb/day						
Off-Road	1.9074	20.2964	14.7270	0.0223		1.1384	1.1384		1.0473	1.0473		2,281.0588	2,281.0588	0.6989			2,295.7360
Paving	0.1697					0.0000	0.0000		0.0000	0.0000			0.0000				0.0000
Total	2.0771	20.2964	14.7270	0.0223		1.1384	1.1384		1.0473	1.0473		2,281.0588	2,281.0588	0.6989			2,295.7360

3.7 Paving - 2017

Unmitigated Construction Off-Site

	ROG	NOx	CO	SO2	Fugitive PM10	Exhaust PM10	PM10 Total	Fugitive PM2.5	Exhaust PM2.5	PM2.5 Total	Bio- CO2	NBio- CO2	Total CO2	CH4	N2O	CO2e	
Category	lb/day										lb/day						
Hauling	0.0000	0.0000	0.0000	0.0000	0.0000	0.0000	0.0000	0.0000	0.0000	0.0000		0.0000	0.0000	0.0000			0.0000
Vendor	0.0000	0.0000	0.0000	0.0000	0.0000	0.0000	0.0000	0.0000	0.0000	0.0000		0.0000	0.0000	0.0000			0.0000
Worker	0.0574	0.0776	0.8097	1.9900e-003	0.1677	1.3500e-003	0.1690	0.0445	1.2400e-003	0.0457		160.9291	160.9291	8.4500e-003			161.1065
Total	0.0574	0.0776	0.8097	1.9900e-003	0.1677	1.3500e-003	0.1690	0.0445	1.2400e-003	0.0457		160.9291	160.9291	8.4500e-003			161.1065

Mitigated Construction On-Site

	ROG	NOx	CO	SO2	Fugitive PM10	Exhaust PM10	PM10 Total	Fugitive PM2.5	Exhaust PM2.5	PM2.5 Total	Bio- CO2	NBio- CO2	Total CO2	CH4	N2O	CO2e	
Category	lb/day										lb/day						
Off-Road	0.5490	11.0645	16.9276	0.0223		0.5982	0.5982		0.5982	0.5982	0.0000	2,281.0588	2,281.0588	0.6989			2,295.7360
Paving	0.1697					0.0000	0.0000		0.0000	0.0000			0.0000				0.0000
Total	0.7187	11.0645	16.9276	0.0223		0.5982	0.5982		0.5982	0.5982	0.0000	2,281.0588	2,281.0588	0.6989			2,295.7360

3.7 Paving - 2017

Mitigated Construction Off-Site

	ROG	NOx	CO	SO2	Fugitive PM10	Exhaust PM10	PM10 Total	Fugitive PM2.5	Exhaust PM2.5	PM2.5 Total	Bio- CO2	NBio- CO2	Total CO2	CH4	N2O	CO2e
Category	lb/day										lb/day					
Hauling	0.0000	0.0000	0.0000	0.0000	0.0000	0.0000	0.0000	0.0000	0.0000	0.0000		0.0000	0.0000	0.0000		0.0000
Vendor	0.0000	0.0000	0.0000	0.0000	0.0000	0.0000	0.0000	0.0000	0.0000	0.0000		0.0000	0.0000	0.0000		0.0000
Worker	0.0574	0.0776	0.8097	1.9900e-003	0.1677	1.3500e-003	0.1690	0.0445	1.2400e-003	0.0457		160.9291	160.9291	8.4500e-003		161.1065
Total	0.0574	0.0776	0.8097	1.9900e-003	0.1677	1.3500e-003	0.1690	0.0445	1.2400e-003	0.0457		160.9291	160.9291	8.4500e-003		161.1065

4.0 Operational Detail - Mobile

4.1 Mitigation Measures Mobile

	ROG	NOx	CO	SO2	Fugitive PM10	Exhaust PM10	PM10 Total	Fugitive PM2.5	Exhaust PM2.5	PM2.5 Total	Bio- CO2	NBio- CO2	Total CO2	CH4	N2O	CO2e
Category	lb/day										lb/day					
Mitigated	3.1824	7.7978	31.0625	0.0757	5.2643	0.1112	5.3756	1.4066	0.1025	1.5091		6,261.2531	6,261.2531	0.2436		6,266.3679
Unmitigated	3.1824	7.7978	31.0625	0.0757	5.2643	0.1112	5.3756	1.4066	0.1025	1.5091		6,261.2531	6,261.2531	0.2436		6,266.3679

4.2 Trip Summary Information

Land Use	Average Daily Trip Rate			Unmitigated	Mitigated
	Weekday	Saturday	Sunday	Annual VMT	Annual VMT
Hotel	1,037.59	1,040.13	755.65	2,380,625	2,380,625
Parking Lot	0.00	0.00	0.00		
Total	1,037.59	1,040.13	755.65	2,380,625	2,380,625

4.3 Trip Type Information

Land Use	Miles			Trip %			Trip Purpose %		
	H-W or C-W	H-S or C-C	H-O or C-NW	H-W or C-W	H-S or C-C	H-O or C-NW	Primary	Diverted	Pass-by
Hotel	16.60	8.40	6.90	19.40	61.60	19.00	58	38	4
Parking Lot	16.60	8.40	6.90	0.00	0.00	0.00	0	0	0

LDA	LDT1	LDT2	MDV	LHD1	LHD2	MHD	HHD	OBUS	UBUS	MCY	SBUS	MH
0.511172	0.060004	0.180590	0.138995	0.042398	0.006681	0.016070	0.032568	0.001938	0.002493	0.004370	0.000586	0.002135

5.0 Energy Detail

4.4 Fleet Mix

Historical Energy Use: N

5.1 Mitigation Measures Energy

	ROG	NOx	CO	SO2	Fugitive PM10	Exhaust PM10	PM10 Total	Fugitive PM2.5	Exhaust PM2.5	PM2.5 Total	Bio- CO2	NBio- CO2	Total CO2	CH4	N2O	CO2e
Category	lb/day										lb/day					
NaturalGas Mitigated	0.0539	0.4903	0.4118	2.9400e-003		0.0373	0.0373		0.0373	0.0373		588.3349	588.3349	0.0113	0.0108	591.9154
NaturalGas Unmitigated	0.0539	0.4903	0.4118	2.9400e-003		0.0373	0.0373		0.0373	0.0373		588.3349	588.3349	0.0113	0.0108	591.9154

5.2 Energy by Land Use - NaturalGas

Unmitigated

	NaturalGas Use	ROG	NOx	CO	SO2	Fugitive PM10	Exhaust PM10	PM10 Total	Fugitive PM2.5	Exhaust PM2.5	PM2.5 Total	Bio- CO2	NBio- CO2	Total CO2	CH4	N2O	CO2e
Land Use	kBTU/yr	lb/day										lb/day					
Hotel	5000.85	0.0539	0.4903	0.4118	2.9400e-003		0.0373	0.0373		0.0373	0.0373		588.3349	588.3349	0.0113	0.0108	591.9154
Parking Lot	0	0.0000	0.0000	0.0000	0.0000		0.0000	0.0000		0.0000	0.0000		0.0000	0.0000	0.0000	0.0000	0.0000
Total		0.0539	0.4903	0.4118	2.9400e-003		0.0373	0.0373		0.0373	0.0373		588.3349	588.3349	0.0113	0.0108	591.9154

5.2 Energy by Land Use - NaturalGas

Mitigated

	NaturalGas Use	ROG	NOx	CO	SO2	Fugitive PM10	Exhaust PM10	PM10 Total	Fugitive PM2.5	Exhaust PM2.5	PM2.5 Total	Bio- CO2	NBio- CO2	Total CO2	CH4	N2O	CO2e
Land Use	kBTU/yr	lb/day										lb/day					
Parking Lot	0	0.0000	0.0000	0.0000	0.0000		0.0000	0.0000		0.0000	0.0000		0.0000	0.0000	0.0000	0.0000	0.0000
Hotel	5.00085	0.0539	0.4903	0.4118	2.9400e-003		0.0373	0.0373		0.0373	0.0373		588.3349	588.3349	0.0113	0.0108	591.9154
Total		0.0539	0.4903	0.4118	2.9400e-003		0.0373	0.0373		0.0373	0.0373		588.3349	588.3349	0.0113	0.0108	591.9154

6.0 Area Detail

6.1 Mitigation Measures Area

Use Low VOC Paint - Non-Residential Interior

Use Low VOC Paint - Non-Residential Exterior

Use only Natural Gas Hearths

	ROG	NOx	CO	SO2	Fugitive PM10	Exhaust PM10	PM10 Total	Fugitive PM2.5	Exhaust PM2.5	PM2.5 Total	Bio- CO2	NBio- CO2	Total CO2	CH4	N2O	CO2e
Category	lb/day										lb/day					
Mitigated	2.9280	2.7000e-004	0.0288	0.0000		1.0000e-004	1.0000e-004		1.0000e-004	1.0000e-004		0.0608	0.0608	1.7000e-004		0.0644
Unmitigated	3.0704	2.7000e-004	0.0288	0.0000		1.0000e-004	1.0000e-004		1.0000e-004	1.0000e-004		0.0608	0.0608	1.7000e-004		0.0644

6.2 Area by SubCategory

Unmitigated

	ROG	NOx	CO	SO2	Fugitive PM10	Exhaust PM10	PM10 Total	Fugitive PM2.5	Exhaust PM2.5	PM2.5 Total	Bio- CO2	NBio- CO2	Total CO2	CH4	N2O	CO2e
SubCategory	lb/day										lb/day					
Architectural Coating	0.4272					0.0000	0.0000		0.0000	0.0000			0.0000			0.0000
Consumer Products	2.6404					0.0000	0.0000		0.0000	0.0000			0.0000			0.0000
Landscaping	2.7500e-003	2.7000e-004	0.0288	0.0000		1.0000e-004	1.0000e-004		1.0000e-004	1.0000e-004		0.0608	0.0608	1.7000e-004		0.0644
Total	3.0704	2.7000e-004	0.0288	0.0000		1.0000e-004	1.0000e-004		1.0000e-004	1.0000e-004		0.0608	0.0608	1.7000e-004		0.0644

6.2 Area by SubCategory

Mitigated

	ROG	NOx	CO	SO2	Fugitive PM10	Exhaust PM10	PM10 Total	Fugitive PM2.5	Exhaust PM2.5	PM2.5 Total	Bio- CO2	NBio- CO2	Total CO2	CH4	N2O	CO2e
SubCategory	lb/day										lb/day					
Architectural Coating	0.2848					0.0000	0.0000		0.0000	0.0000			0.0000			0.0000
Consumer Products	2.6404					0.0000	0.0000		0.0000	0.0000			0.0000			0.0000
Landscaping	2.7500e-003	2.7000e-004	0.0288	0.0000		1.0000e-004	1.0000e-004		1.0000e-004	1.0000e-004		0.0608	0.0608	1.7000e-004		0.0644
Total	2.9280	2.7000e-004	0.0288	0.0000		1.0000e-004	1.0000e-004		1.0000e-004	1.0000e-004		0.0608	0.0608	1.7000e-004		0.0644

7.0 Water Detail

7.1 Mitigation Measures Water

8.0 Waste Detail

8.1 Mitigation Measures Waste

9.0 Operational Offroad

Equipment Type	Number	Hours/Day	Days/Year	Horse Power	Load Factor	Fuel Type
----------------	--------	-----------	-----------	-------------	-------------	-----------

10.0 Vegetation

Appendix D
Hydrology Study



PROJECT SITE:

U.S. 101 Highway, Las Virgenes Road and Rondell Street
Calabasas, California

Rondell Oasis Hotel

PREPARED FOR:

Rondell Oasis LLC
C/o Weintraub Real Estate Group
P. O. Box 6528
Malibu, CA 90264
Tel: (310) 457-8130

PREPARED BY:

Spindler Engineering, Inc.
16823 Saticoy Street
Van Nuys, California 91406
Tel (818) 782-2788
Job No. 7467.01

August, 2014

Revised January 23, 2015



Drainage Concept

Introduction

This Hydrology Study addresses the hydrological issues associated with the proposed development of Rondell Oasis Hotel in City of Calabasas, County of Los Angeles. The total tributary area to the site and including the site encompasses approximately 35 acres of undeveloped land at the south east corner of intersection of 101 freeway and Las Virgenes Road.

Existing Conditions

The project site in its existing condition consists of two natural watershed tributaries which drain in general westerly direction to an existing inlet on Cal Trans Right of Way.

Proposed Development

The proposed development is approximately 5 acres of fairly flat portion of the tributary which is just to the east of the existing inlet in Las Virgenes Road. This development will cause an increase in the discharge of about 7 cfs for a 50 year storm which will be detained on site through a proposed debris/detention basin on the North side of the building in the parking lot approximately 12 feet north of the utility corridor and the LVMWD water mains.

The detained water causes an additional water height of about 6' which can go on top of the stored debris in the basin creating a water height elevation approximately 778 with an overflow at 779.

- The detention tank underneath the parking lot will have a 2 stand pipes inside the basin, which will provide a method of controlling the water and debris as follows.
 - For debris, there will be a slotted stand pipe, which will be designed to allow the debris to settle in the basin and drain reasonably clear water to the storm drain system, which would connect with the pipe overflow pipe. This pipe would be restricted to detain water at the peak of the storm so as to not exceed pre-construction levels during the peak storm.
 - A second and larger stand pipe without slots, would be set above the first stand pipe to serve as an over flow in the event the first pipe becomes plugged. This stand pipe would then tie into the storm drain adjacent to the Las Virgenes Road freeway on ramp.

The basin will be privately maintained and is designed so that a small Bob-Cat or other similar piece of equipment can access the basin and remove debris as needed.

There will be a second debris basin in the location of the existing basin on the south side of the building. This basin will be designed to hold 345 CY of debris and will have a 9.5 foot high retaining wall around the north and west side of the basin. This basin will have a stand pipe to serve both filtration of the debris and as an over flow in the event the slots in the pipe become plugged. This stand pipe would then tie into the storm drain adjacent to the Las Virgenes Road freeway on ramp. This

stand pipe would then tie into the storm drain adjacent to the Las Virgenes Road freeway on ramp.

B.M.P. Measures (SWPPP) and (SUSMP)

This project will incorporate Best Management Practices (B.M.P.s) guidelines and standards. A Storm Water Pollution Prevention Plan (SWPPP) will be prepared prior to issuance of a Grading Permit and uploaded to the State SMARTS SWPPP web site. The SWPPP will provide guidelines for best management during construction.

The Standard Urban Storm Water Mitigated Plan (SUSMP) will be prepared based on the following concept.

- The first flush water for all impervious portions of the site including the roof of the building, will be captured before the water goes into the storm drain line, which connects to the storm drain in the Las Virgenes Road freeway on ramp. This is generally performed by placing a smaller pipe in certain catch basins that will carry no more water than the first flush allowing major flows to bi-pass to the storm drain. This first flush water will be taken either to a rain water harvesting tank for reuse in the landscaping of the site or to infiltration cells to recharge the ground water. The final decision on whether to use rainwater harvesting tanks or ground water recharge or a combination of both will be based on Soils and Geological report on the site, which will include percolation rates if ground water recharge is selected. The amount of water that will need to go either to the rain water harvesting tanks or ground water re charge or both is calculated to the 58,228 gallons, calculations for this re charge amount are shown below.

Rondell – SUSMP Volume (Preliminary)

Area of pad area (On-site): 86,500 Sq. Ft.

Area of Rondell (Off-site parking): 38,052 Sq. Ft.

At $\frac{3}{4}$ " of rain to be mitigated:

On-site: $86,500 \times \frac{3}{4} " = 5,406 \text{ Cu. Ft}$

$5406 \times 7.48 = 40,439 \text{ Gallons}$

Off-site: $38,052 \times \frac{3}{4} " = 2,378 \text{ Cu. Ft.}$

$2378 \times 7.48 = 17,789 \text{ Gallons}$

$40,439 + 17,789 = 58,228 \text{ Gallons}$

**Los Angeles County Criteria For
Debris Production – Rondell Oasis Hotel**

Job No. 7467.01

Project Tributary area falls in DPA = 6

Debris = 48,000 CY per 640 acres (75.0 CY/AC)

North Area = 27.2 acres

North Debris = 2040 CY to underground basin

South Area = 4.6 acres

South Debris = 345 CY to modified basin

DEBRIS PRODUCTION RATE IN CUBIC YARDS PER SQUARE MILE

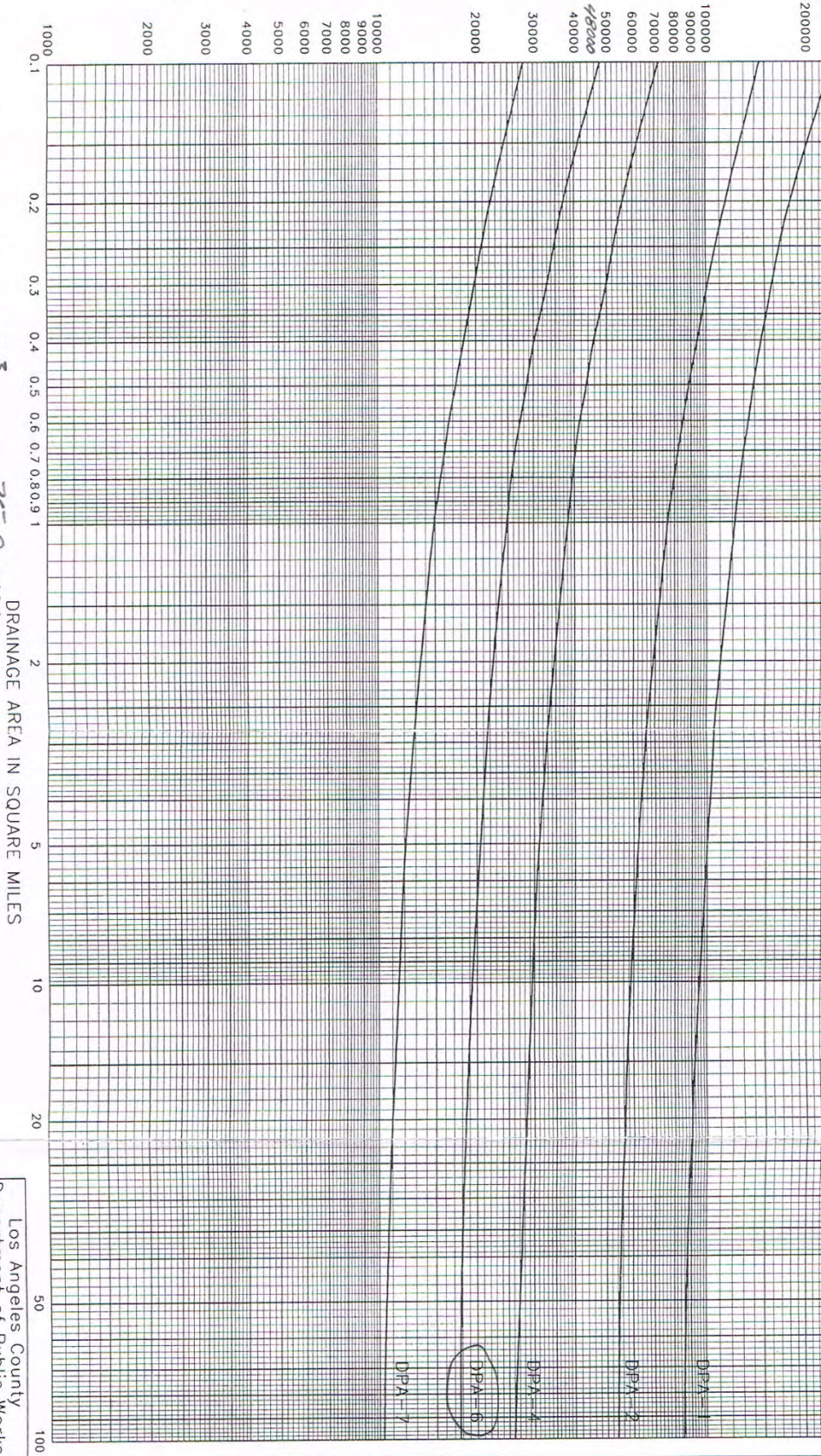

$D.P. = 48,000 \text{ CY}^3 / 640 \text{ AC} / \text{MI}^2 = 75.0 \text{ CY} / \text{AC}$

Los Angeles County
 Department of Public Works
 DEBRIS PRODUCTION RATES
 for Los Angeles Basin

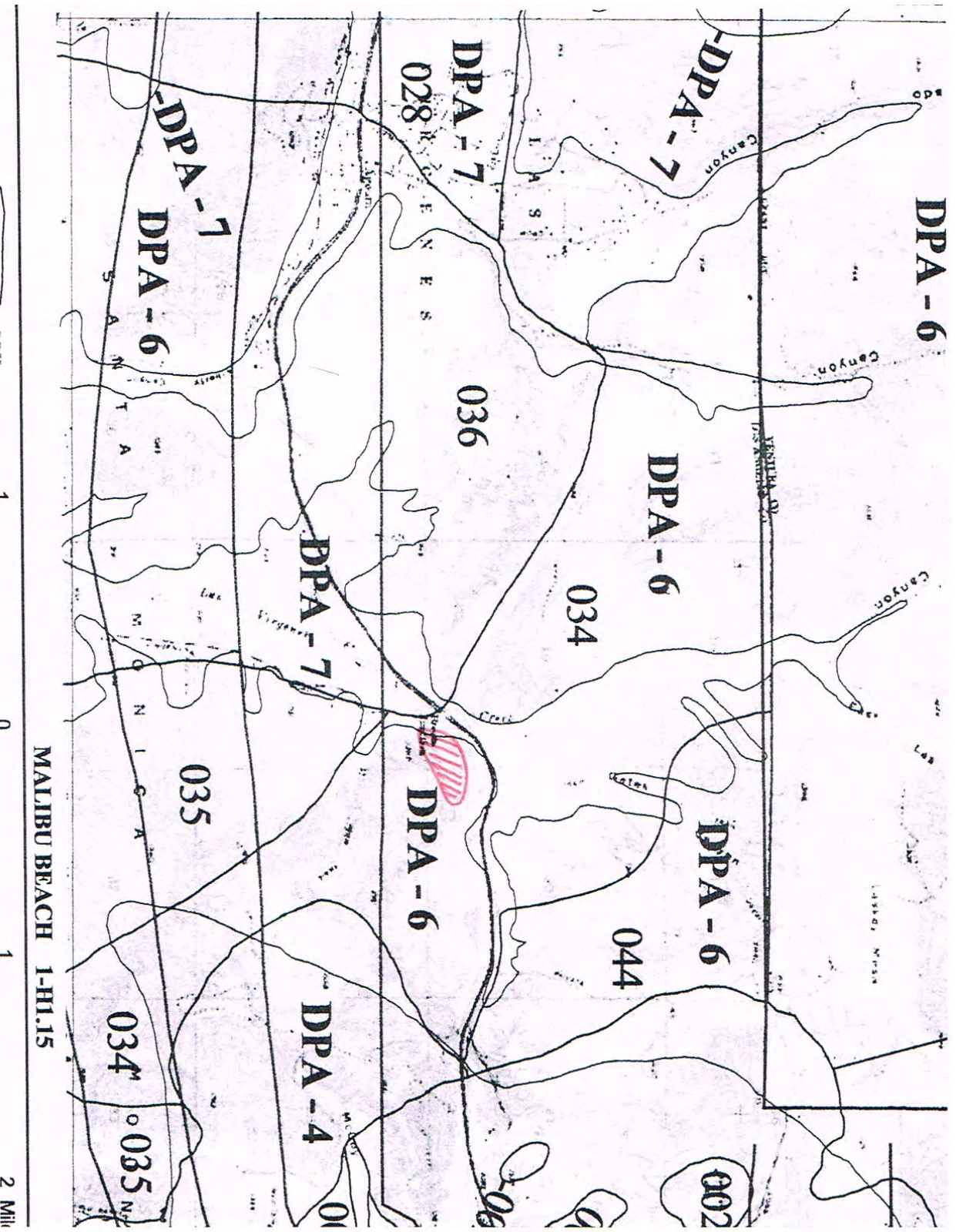

Pre & Post Hydrology Calculations

746U.OUT

8/8/2014

PRE

Program Package Serial Number: 2050
 08/08/14 FILE: 746U INPUT DATA: English Units RAINFALL SOIL FILE: English (In) OUTPUT DATA: English Units PAGE 1
 LOS ANGELES COUNTY FLOOD CONTROL DISTRICT F0601M PROG

MODIFIED RATIONAL METHOD HYDROLOGY - STORM YEAR = 50 SOIL DATA FILE: C:\Program Files\Civild\lar04 & Retard
 exe file\la

S.E.C. CIVIL ENGR'S, JOB NO. 7467.01 Weintraub
 SUBAREA SUBAREA TOTAL TOTAL CONVE CONVE CONVE CONVE CONVE CONVE CONVE CONVE CONTROL SOIL RAIN RAIN
 LOCATION AREA(AC) Q(CFS) AREA(AC) Q(CFS) TYPE LENGTH(FT) SLOPE SIZE(FT) Z Q(CFS) NAME TC ZONE IMPV DAY 4
 5 1A 11.8 77.3 48. 11.8 77.3 1 1 872. 12040 .00 .00 0. 234 5 5 A37 .01
 5 2A 15.4 94.8 57. 27.2 145.1 2 2 346. 08090 .00 .00 0. 234 6 6 A37 .01
 5 3A 3.0 19.3 12. 30.2 141.0 0 0 0. 00000 .00 .00 0. 234 5 5 A37 .01
 5 4B 4.6 30.6 19. 4.6 30.6 2 2 310. 05160 .00 .00 0. 234 5 5 A37 .01

CONFLUENCE Q'S

5 5A TA 1155 QA 100. QAB 116. QB 17. 5 5B TB 1154 QB 18. QBA 117. QA 99.
 5 SAB TAB 1154 QAB 117. QA 18.

SUBAREA SUBAREA TOTAL TOTAL CONVE CONVE CONVE CONVE CONVE CONVE CONTROL SOIL TC RAIN RAIN PCT
 LOCATION AREA(AC) Q(CFS) AREA(AC) Q(CFS) TYPE LENGTH(FT) SLOPE SIZE(FT) Z Q(CFS) NAME TC ZONE IMPV
 5 5AB 4.6 18. 34.8 188.4 4 4 100. 03000 3.00 .00 0. 234 0 A37 .00

746d.OUT

8/12/2014

Program Package Serial Number: 2050
 08/12/14 FILE: 746d INPUT DATA: English Units RAINFALL SOIL FILE: English (In) OUTPUT DATA: English Units PAGE 1
 LOS ANGELES COUNTY FLOOD CONTROL DISTRICT F0601M PROG

POST

MODIFIED RATIONAL METHOD HYDROLOGY - STORM YEAR = 50 SOIL DATA FILE: C:\Program
 Files\Civil\1ar04\1ar soilx_71.dat
 S.E.C. CIVIL ENGR'S, JOB NO. 7467.01 Weintraub

LOCATION	AREA(AC)	Q(CFS)	TOTAL AREA(AC)	TOTAL Q(CFS)	CONV TYPE	CONV LNPTH(FT)	CONV SLOPE	CONV SIZE(FT)	CONV Z	CONV Q(CFS)	CONTROL SOIL NAME	TC	RAIN ZONE	RAIN PCT
5	1A	11.8	11.8	48.	1	872.	.12040	.00	.00	0.	234	5	A37	.01
5	2A	15.4	27.2	92.	2	346.	.08090	.00	.00	0.	234	6	A37	.01
5	3A	4.7	31.9	21.	0	0.	.00000	.00	.00	0.	234	5	A37	.90
5	4B	4.6	4.6	19.	2	310.	.05160	.00	.00	0.	234	5	A37	.01

CONFLUENCE Q'S

5	5A	TA	1154	QA	107.	QAB	124.	QB	18.	5	5B	TB	1154	QB	18.	QBA	124.	QA	107.
5	5AB	TAB	1154	QAB	124.	QA	107.	QB	18.										

LOCATION	SUBAREA AREA(AC)	SUBAREA Q(CFS)	TOTAL AREA(AC)	TOTAL Q(CFS)	CONV TYPE	CONV LNPTH(FT)	CONV SLOPE	CONV SIZE(FT)	CONV Z	CONV Q(CFS)	CONTROL SOIL NAME	TC	RAIN ZONE	RAIN PCT
5	5AB	4.6	36.5	124.	4	100.	.03000	3.25	.00	0.	234	0	A37	.00

*Discharge to be
 Detained, ΔQ = Q_{POST@INLET} - Q_{PRE@INLET}*

ΔQ = 124 - 117 = 7 cfs

About 10 cfs will be detained

∴ Post = 124 - 10 = 114 cfs < 117 cfs

1

OK

parameters

PRE & POST

Tc Calculator

Subarea No.	Area (acres)	Imp %	Frequency	Soil Type	Length	Slope	Isotvet
1A	11.8	0.01	50	34	999	0.2252	7.4

Equation, given parameters above:

Undeveloped subarea coeff. (0<=Imp<21):
 $b_0 = -0.507$
 $b_1 = -0.519$
 $b_2 = 0.483$
 $b_3 = -0.135$
 $b_4 = 0$

Equations for Tc: $Tc = (10)^{b_0 + b_1(L) + b_2(S) + b_3}$
 (1440) $b_0 = -0.507$
 $b_1 = -0.519$
 $b_2 = 0.483$
 $b_3 = -0.135$
 $b_4 = 0$

Undeveloped subarea coeff. (Imp=0)

Undeveloped subarea coeff. (0<=Imp<21)

Developed subarea coeff. (21<=Imp<68)

Developed subarea coeff. (68<=Imp<1)

Iterations **RESET** Tc estimate: 5.28
 Z 5.71
 Tolerance (min) 0.5

RUN Diff: 0.45
 Interpolated value for I: Tc:high 6.00
 Tc:low 5.00

Cu 0.89
 Cd 0.89
 13.14
 14.32

13.48
 4.18
 13.45

Use Tc value: 5.00 minutes

parameters

PRE & POST

Tc Calculator

Subarea No.	Area (acres)	Imp %	Frequency	Soil Type	Length	Slope	Isolyel
2A	15.4	0.01	50	34	872	0.1204	7.4

Equation, given parameters above:

$b_0 = -0.507$ $Tc = (10 \times 0.507 \times (Cd)^{0.483}) - 0.519 \times (L)^{0.483} \times (S)^{-0.135}$
 $b_1 = -0.519$
 $b_2 = 0.483$
 $b_3 = -0.135$
 $b_0 = 0$

Undeveloped subarea coeff (1<math>S^{b_3}</math>)

$b_0 = -0.507$
 $b_1 = -0.519$
 $b_2 = 0.483$
 $b_3 = -0.135$

Undeveloped subarea coeff (0S^{b_3} 21)

$b_0 = -0.507$
 $b_1 = -0.519$
 $b_2 = 0.483$
 $b_3 = -0.135$

Developed subarea coeff (21S^{b_3} 693)

$b_0 = -0.507$
 $b_1 = -0.519$
 $b_2 = 0.483$
 $b_3 = -0.135$

Developed subarea coeff (68S^{b_3} 1)

$b_0 = -0.507$
 $b_1 = -0.519$
 $b_2 = 0.483$
 $b_3 = -0.135$

Equations for Tc: $Tc = (10 \times b_0 \times (Cd)^{b_1} \times (L)^{b_2} \times (S)^{b_3}$

11440=IsolyelZ/dhrs: 0.308
 1c=11440/3071440: 4.102

Iterations **RESET**
 Z 5.85
 Tc estimate: 5.94
 Tc-calc: 5.94
 Diff: 0.21
RUN
 Tc-low: 5.00
 Tc-high: 6.00
 Tolerance (min): 0.5

Interpolated value for I: Tc-high 6.00
 Tc-low 5.00
 101440 low 801440 high interpolated 81440
 13.14 14.32 13.32
 (1440/Tc)^0.47
 13.30

Use Tc value: 6.00 minutes

parameters

PRE ONLY

Tc Calculator

Subarea No.	Area (acres)	Imp %	Frequency	Soil Type	Length	Slope	Isotvel
3A	3	0.01	50	3A	346	0.0809	7.4

Equation, given parameters above: $Tc = (10)^{bo} \cdot 507^{b1} \cdot (Cd)^{b2} \cdot 0.519^{b3} \cdot (L)^{b4} \cdot 0.483^{b5} \cdot (S)^{b6} \cdot 0.135^{b7}$

Undeveloped subarea coeff (0 < %imp < 21):
 bo = -0.507
 b1 = -0.519
 b2 = 0.483
 b3 = -0.135
 b4 = 0

Developed subarea coeff (21 < %imp < 69):
 bo = -0.507
 b1 = -0.519
 b2 = 0.483
 b3 = -0.135
 b4 = 0

Developed subarea coeff (68 < %imp < 1):
 bo = -0.507
 b1 = -0.519
 b2 = 0.483
 b3 = -0.135
 b4 = 0

Equations for Tc: $Tc = (10)^{bo} \cdot 507^{b1} \cdot (Cd)^{b2} \cdot (L)^{b4} \cdot 0.47^{b5} \cdot (S)^{b6}$

Iterations: 2
 Tc estimate: 3.82
 Tc calc: 3.82
 DIF: 0.00
 RUN
 Interpolated value for L: 4.00
 Tc high: 3.00
 Tc low: 14.32
 Iterations low: 14.32
 Iterations high: 14.32
 Interpolated: 14.32
 IL: 4.42
 (1440/Tc)^0.47: 14.32

Use Tc value: 5.00 minutes

Q50 = 11.8 cfs

parameters

PRE & POST

Tc Calculator

Subarea No.	Area (acres)	Imp %	Frequency	Soil Type	Length	Slope	Isotvet
4B	4.6	0.01	50	34	827	0.2569	7.4

Equation, given parameters above:

Undeveloped subarea coeff. (0<Stamp<21):

$$Tc = (10)^{-0.507} (Cd)^{0.519} (L)^{0.483} (S)^{-0.135}$$

Undeveloped subarea coeff. (0<Stamp<21):

$$Tc = (10)^{-0.507} (Cd)^{0.519} (L)^{0.483} (S)^{-0.135}$$

Developed subarea coeff. (21<Stamp<69):

$$Tc = (10)^{-0.507} (Cd)^{0.519} (L)^{0.483} (S)^{-0.135}$$

Developed subarea coeff. (68<Stamp<1):

$$Tc = (10)^{-0.507} (Cd)^{0.519} (L)^{0.483} (S)^{-0.135}$$

Iterations

RESET

Tc estimate: 4.47

Tc calc: 4.36

Diff: 0.11

RUN

Cu: 0.89

Cd: 0.89

W=Cd¹: 3.900

Il: 4.42

Z

Interpolated value for I:

Tc high: 5.00

Tc low: 4.00

011440 low: 14.32

011440 high: 14.32

11440Tc: 14.32

(1440Tc)^0.47: 14.32

Tolerance (min)

0.5

Use Tc value: 5.00 minutes

parameters

POST, Area = 4.7 Ac

POST ONLY

Tc Calculator

Subarea No.	Area (acres)	Imp %	Frequency	Soil Type	Length	Slope	Isolyel
3A	4.7	0.0	50	3A	3.46	0.0000	7.4

Equation, given parameters above:
Developed subarea coeff. (88\leqimp\leq1):

$b_0 = -0.507$
 $b_1 = -0.519$
 $b_2 = 0.483$
 $b_3 = -0.135$
 $b_4 = 0$

$b_0 = -0.507$
 $b_1 = -0.519$
 $b_2 = 0.483$
 $b_3 = -0.135$
 $b_4 = 0$

$b_0 = -0.507$
 $b_1 = -0.519$
 $b_2 = 0.483$
 $b_3 = -0.135$
 $b_4 = 0$

$b_0 = -0.507$
 $b_1 = -0.519$
 $b_2 = 0.483$
 $b_3 = -0.135$
 $b_4 = 0$

$b_0 = -0.507$
 $b_1 = -0.519$
 $b_2 = 0.483$
 $b_3 = -0.135$
 $b_4 = 0$

$b_0 = -0.507$
 $b_1 = -0.519$
 $b_2 = 0.483$
 $b_3 = -0.135$
 $b_4 = 0$

$b_0 = -0.507$
 $b_1 = -0.519$
 $b_2 = 0.483$
 $b_3 = -0.135$
 $b_4 = 0$

$b_0 = -0.507$
 $b_1 = -0.519$
 $b_2 = 0.483$
 $b_3 = -0.135$
 $b_4 = 0$

$b_0 = -0.507$
 $b_1 = -0.519$
 $b_2 = 0.483$
 $b_3 = -0.135$
 $b_4 = 0$

$b_0 = -0.507$
 $b_1 = -0.519$
 $b_2 = 0.483$
 $b_3 = -0.135$
 $b_4 = 0$

$b_0 = -0.507$
 $b_1 = -0.519$
 $b_2 = 0.483$
 $b_3 = -0.135$
 $b_4 = 0$

$b_0 = -0.507$
 $b_1 = -0.519$
 $b_2 = 0.483$
 $b_3 = -0.135$
 $b_4 = 0$

$b_0 = -0.507$
 $b_1 = -0.519$
 $b_2 = 0.483$
 $b_3 = -0.135$
 $b_4 = 0$

$b_0 = -0.507$
 $b_1 = -0.519$
 $b_2 = 0.483$
 $b_3 = -0.135$
 $b_4 = 0$

$b_0 = -0.507$
 $b_1 = -0.519$
 $b_2 = 0.483$
 $b_3 = -0.135$
 $b_4 = 0$

$b_0 = -0.507$
 $b_1 = -0.519$
 $b_2 = 0.483$
 $b_3 = -0.135$
 $b_4 = 0$

$b_0 = -0.507$
 $b_1 = -0.519$
 $b_2 = 0.483$
 $b_3 = -0.135$
 $b_4 = 0$

$b_0 = -0.507$
 $b_1 = -0.519$
 $b_2 = 0.483$
 $b_3 = -0.135$
 $b_4 = 0$

$b_0 = -0.507$
 $b_1 = -0.519$
 $b_2 = 0.483$
 $b_3 = -0.135$
 $b_4 = 0$

$b_0 = -0.507$
 $b_1 = -0.519$
 $b_2 = 0.483$
 $b_3 = -0.135$
 $b_4 = 0$

$b_0 = -0.507$
 $b_1 = -0.519$
 $b_2 = 0.483$
 $b_3 = -0.135$
 $b_4 = 0$

$b_0 = -0.507$
 $b_1 = -0.519$
 $b_2 = 0.483$
 $b_3 = -0.135$
 $b_4 = 0$

$b_0 = -0.507$
 $b_1 = -0.519$
 $b_2 = 0.483$
 $b_3 = -0.135$
 $b_4 = 0$

Q = 50 = 18.7 cfs

Iterations: 2
 Tolerance (min): 0.5
 Tc-estimate: 3.99
 Tc-calc: 0.00
 Df: 0.00
 RUN
 Interpolated value for T: Tc-high 4.00 Tc-low 3.00
 Use Tc value: 5.00 minutes

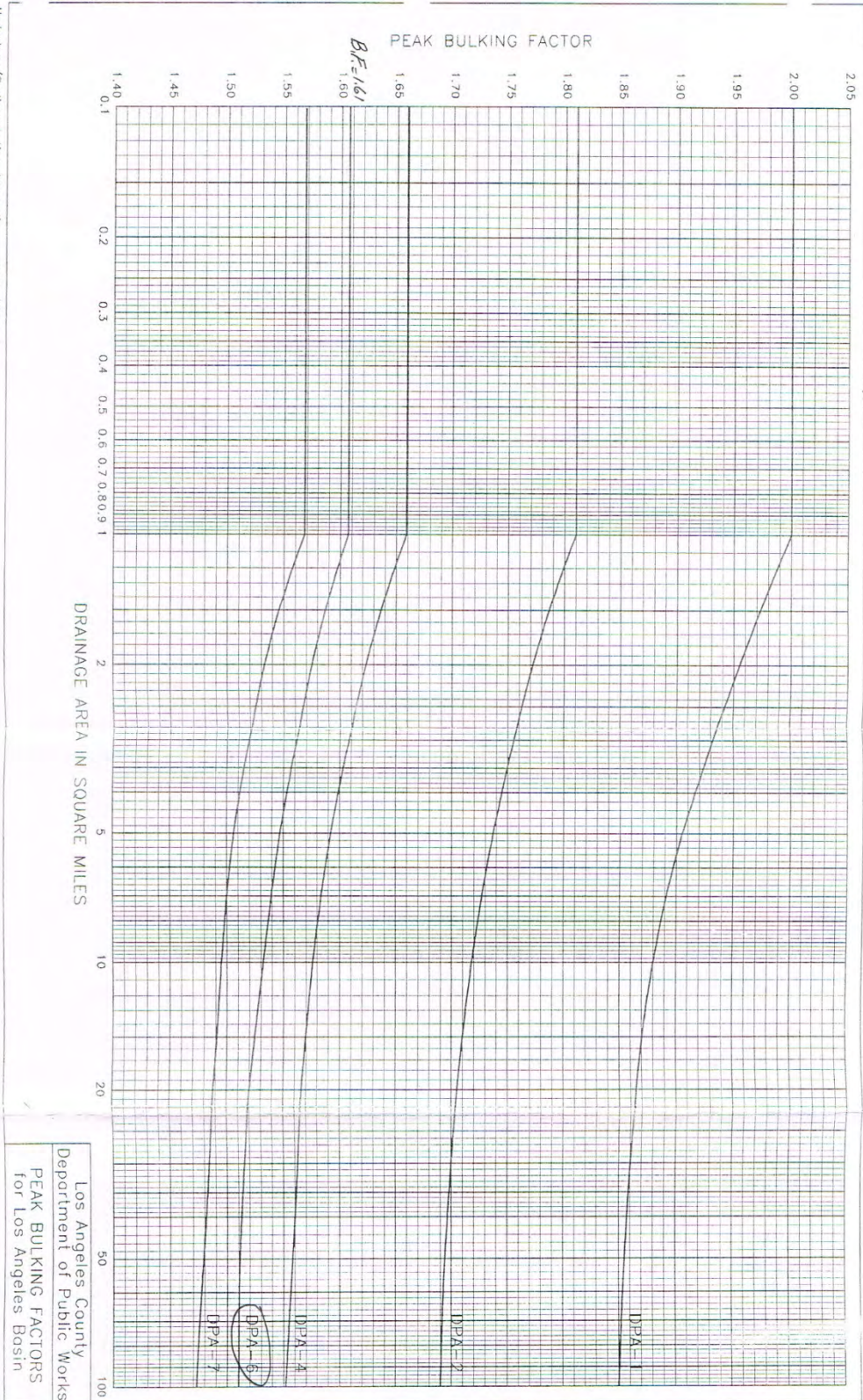

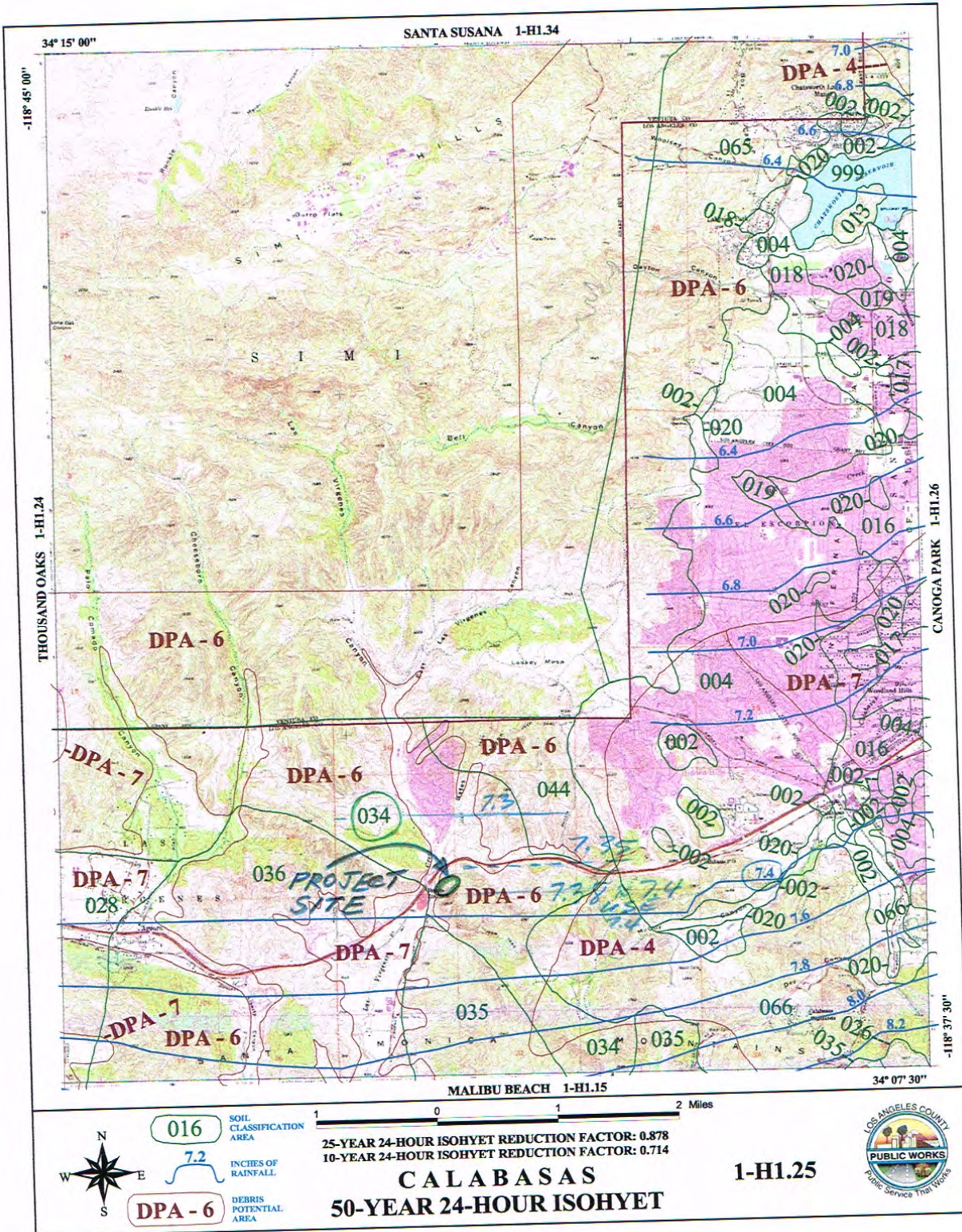

- 016 SOIL CLASSIFICATION AREA
- 7.2 INCHES OF RAINFALL
- DPA-6 DEBRIS POTENTIAL AREA



25-YEAR 24-HOUR ISOHYET REDUCTION FACTOR: 0.878
 10-YEAR 24-HOUR ISOHYET REDUCTION FACTOR: 0.714

CALABASAS
50-YEAR 24-HOUR ISOHYET

1-HI.25



Hydrology Maps

LEGEND:

- TRACT BOUNDARY
 - STREET CENTERLINE
 - PAVED DRAIN AND DOWNDRAIN
 - DAYLIGHT LINE
 - DIRECTION OF FLOW
 - PROPOSED SLOPE AS INDICATED
 - STORM DRAIN LINE
 - CATCH BASIN
 - DRAINAGE AREA DESIGNATION
 - OVERLAND PATH & LENGTH
 - DRAINAGE AREA BOUNDARY
- Q_{25} - 25 YEAR FREQUENCY FLOW RATE
 Q_{50} - 50 YEAR FREQUENCY FLOW RATE
 Q_{CB} - Q CATCH BASIN
 Q_{IN} - Q INLET
 Q_{OUT} - Q OUTLET
 A - SUBAREA IN ACRE
 ΣA - SUMMATION OF AREA
 ΣQ - SUMMATION OF FLOW RATE
 T_c - TIME OF CONCENTRATION IN MINUTE
 $T.E.L.$ - TOP ELEVATION
 $B.E.L.$ - BOTTOM ELEVATION

HYDROLOGY INFORMATION

RAINFALL ZONE: K
 SOIL TYPE: 034
 FREQUENCY: 50 YEAR
 IMPERVIOUSNESS: 1% (OPEN SPACE)
 92% (COMMERCIAL)
 DEBRIS ZONE: DPA-6
 DEBRIS POTENTIAL (DP): 75 CY/AC
 BULKING RATE: 1.61
 RUNOFF COEFFICIENT: $C_p = 1.0 - K(1.0 - C)$
 K = BURNED FACTOR
 $Q_u = C_p A$ (BURNED)
 $Q_{50} = 1.61 Q_u$ (BURNED & BULKED)

DRAINAGE CONCEPT NOTES:

1. HYDROLOGY INFORMATION AND STORM DRAIN ALIGNMENTS SHOWN ARE NOT NECESSARILY APPROVED
2. COMPLIANCE OF ALL STREET DRAINAGE REQUIREMENTS WILL BE MET TO THE SATISFACTION OF THE DEPARTMENT OF PUBLIC WORKS.
3. NECESSARY EASEMENTS WILL BE DEDICATED FOR THE STORM DRAIN SYSTEM TO THE SATISFACTION OF THE DEPARTMENT OF PUBLIC WORKS.
4. VEHICULAR ACCESS WILL BE PROVIDED TO ALL INLETS AND OUTLETS TO THE SATISFACTION OF THE DEPARTMENT OF PUBLIC WORKS.
5. APPROVAL OF THE DRAINAGE CONCEPT DOES NOT CONSTITUTE DETERMINATION THAT THE OFFSITE IMPROVEMENTS ARE REQUIRED WITHIN THE MEANING OF GOVERNMENT CODE SECTION 66462.5, (EXCEPT AS NOTED).
6. AN OFFSITE DRAINAGE COVENANT FOR ACCEPTANCE OF DRAINAGE (AND DRAINAGE FACILITIES) MY BE REQUIRED WHERE INDICATED.
7. A NOTE FOR FLOOD HAZARD MAY BE REQUIRED WHERE INDICATED ON THIS PLAN.
8. A DRAINAGE BENEFIT ASSESSMENT AREA WILL BE REQUIRED FOR THE MAINTENANCE OF THE PROPOSED DETENTION BASIN AND STORM DRAIN FACILITIES.
9. A SOIL REPORT WILL BE REQUIRED TO VERIFY THAT A 7-DAY PERCOLATION RATE CAN BE OBTAINED.

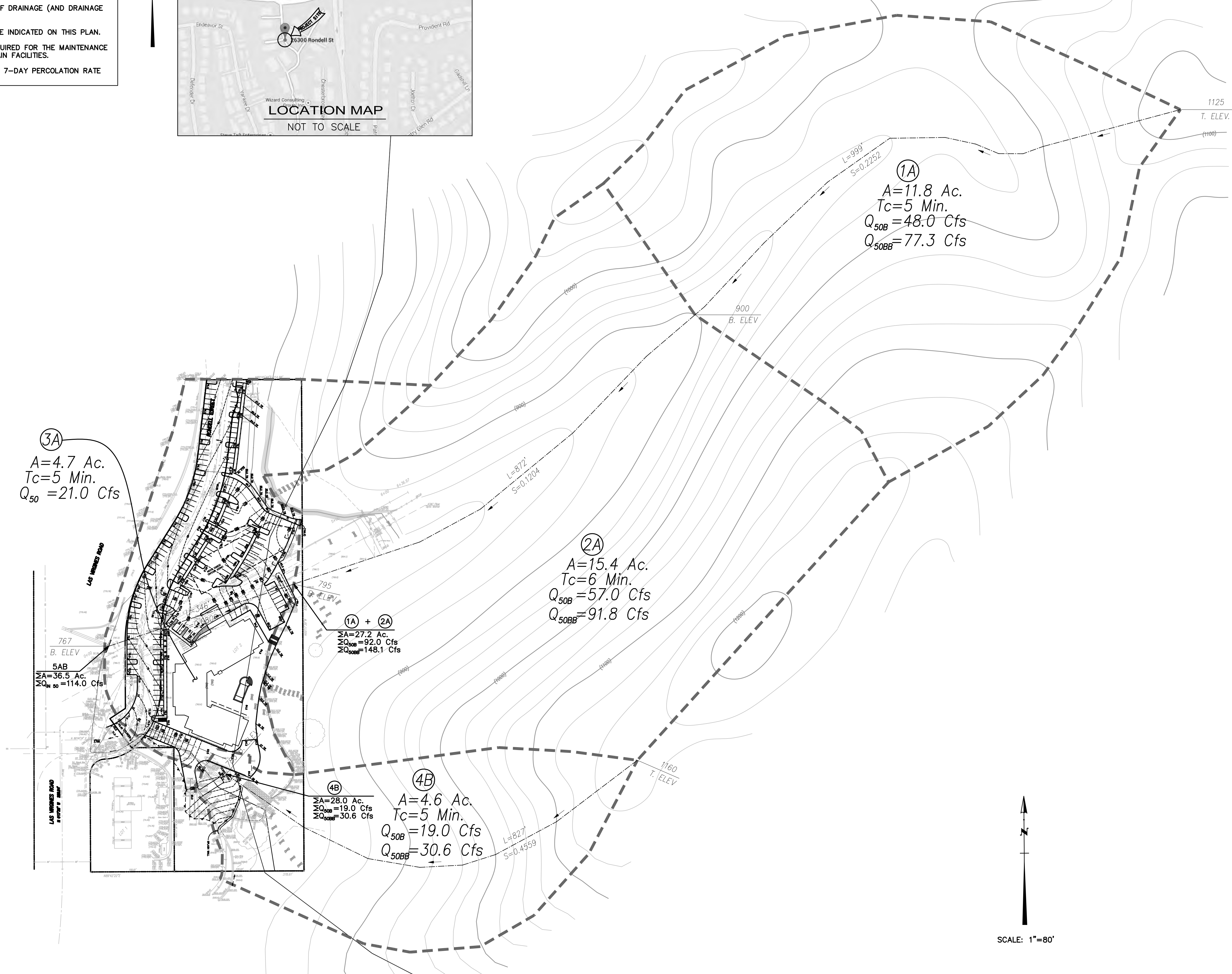
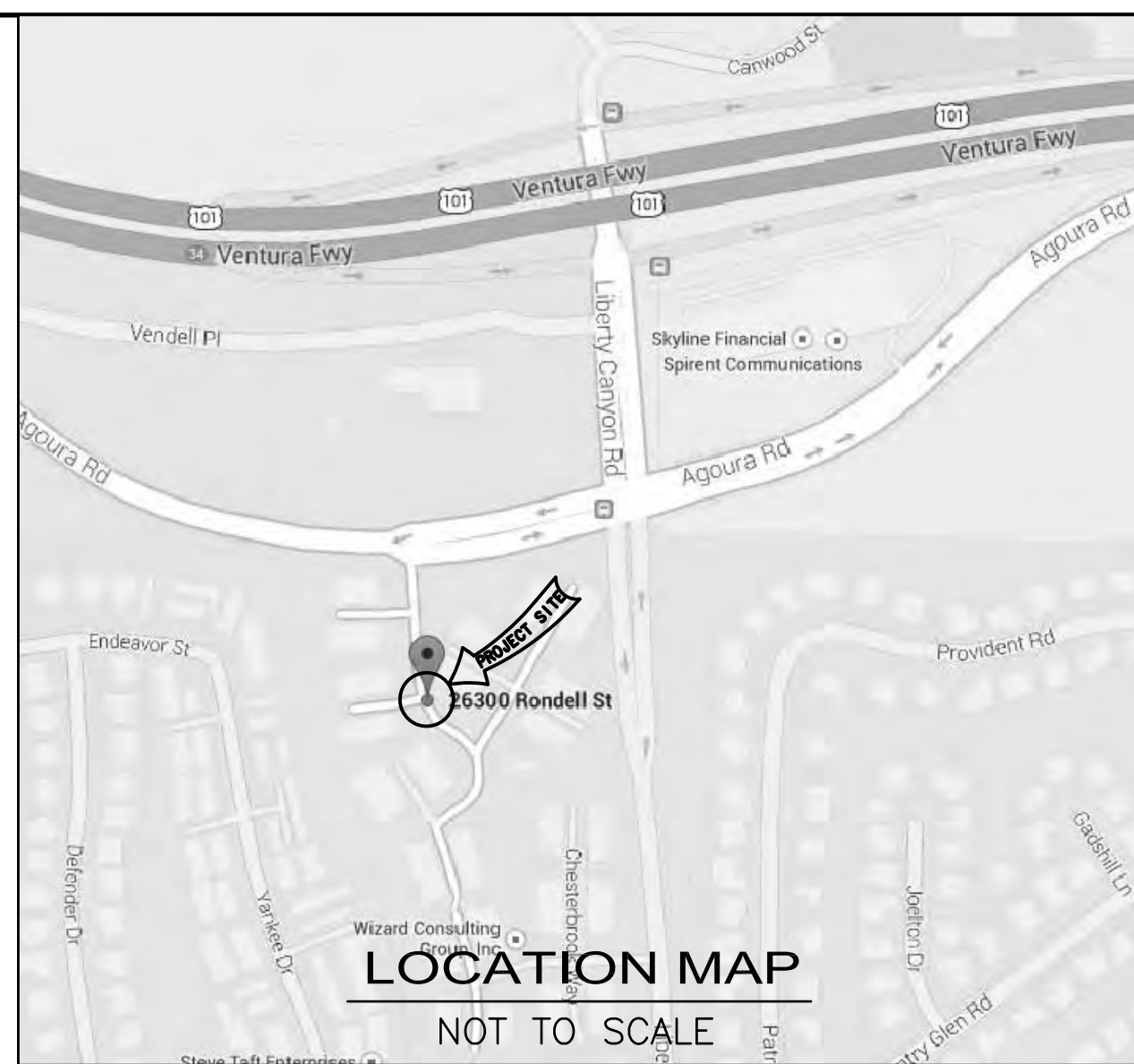

SCALE: 1"=80'

NO.	BY	DATE	SHEET	DESCRIPTION
REVISIONS				
				SHEET 1 OF 1
SPINDLER ENGINEERING CP 18823 SATICOY STREET VAN NUYS, CA 91408 (818) 782-2788 (323) 873-1788 FAX: (818) 782-0111 RONALD W. SPINDLER R.C.E. 13194				
CLIENT:				WEINTRAUB FINANCIAL SERVICES, INC.
PROJECT:				POST DEVELOPMENT HYDROLOGY PLAN

These plans are instruments of service and the property of Spindler Engineering CP. All information contained on these drawings is for use on this specified project. If plans are provided in an electronic format (computer disk, compact disk, or via e-mail or modern transmission, etc) as a courtesy to our client, the delivery of electronic files does not constitute the delivery of our professional work product. Only paper prints signed by a registered engineer employed by Spindler Engineering CP constitute our professional work product. Spindler Engineering CP shall not be responsible for any modifications made to the electronic files, or for any products derived from electronic files which are not reviewed and signed by a registered engineer employed by Spindler Engineering CP.

Copyright: Spindler Engineering CP
 All rights Reserved.

LEGEND:

- TRACT BOUNDARY
 - STREET CENTERLINE
 - PAVED DRAIN AND DOWNDRAIN
 - DAYLIGHT LINE
 - DIRECTION OF FLOW
 - 2:1 --- PROPOSED SLOPE AS INDICATED
 - STORM DRAIN LINE
 - CATCH BASIN
 - DRAINAGE AREA DESIGNATION
 - OVERLAND PATH & LENGTH
 - DRAINAGE AREA BOUNDARY
- Q25 - 25 YEAR FREQUENCY FLOW RATE
 Q50 - 50 YEAR FREQUENCY FLOW RATE
 QCB - Q CATCH BASIN
 QIN - Q INLET
 QOUT - Q OUTLET
 A - SUBAREA IN ACRE
 ΣA - SUMMATION OF AREA
 ΣQ - SUMMATION OF FLOW RATE
 Tc - TIME OF CONCENTRATION IN MINUTE
 T.E.L. - TOP ELEVATION
 B.E.L. - BOTTOM ELEVATION

HYDROLOGY INFORMATION

- RAINFALL ZONE: K
 SOIL TYPE: 034
 FREQUENCY: 50 YEAR
 IMPERVIOUSNESS: 1% (OPEN SPACE)
 92% (COMMERCIAL)
 DEBRIS ZONE: DPA-6
 DEBRIS POTENTIAL (DP): 75 CY/AC
 BULKING RATE: 1.61
 RUNOFF COEFFICIENT: $C_p = 1.0 - K(1.0 - C)$
 K = BURNED FACTOR
 FLOW RATE: $Q_u = C_p A$ (BURNED)
 $Q_{50} = 1.61 Q_u$ (BURNED & BULKED)

DRAINAGE CONCEPT NOTES:

1. HYDROLOGY INFORMATION AND STORM DRAIN ALIGNMENTS SHOWN ARE NOT NECESSARILY APPROVED
2. COMPLIANCE OF ALL STREET DRAINAGE REQUIREMENTS WILL BE MET TO THE SATISFACTION OF THE DEPARTMENT OF PUBLIC WORKS.
3. NECESSARY EASEMENTS WILL BE DEDICATED FOR THE STORM DRAIN SYSTEM TO THE SATISFACTION OF THE DEPARTMENT OF PUBLIC WORKS.
4. VEHICULAR ACCESS WILL BE PROVIDED TO ALL INLETS AND OUTLETS TO THE SATISFACTION OF THE DEPARTMENT OF PUBLIC WORKS.
5. APPROVAL OF THE DRAINAGE CONCEPT DOES NOT CONSTITUTE DETERMINATION THAT THE OFFSITE IMPROVEMENTS ARE REQUIRED WITHIN THE MEANING OF GOVERNMENT CODE SECTION 66462.5, (EXCEPT AS NOTED).
6. AN OFFSITE DRAINAGE COVENANT FOR ACCEPTANCE OF DRAINAGE (AND DRAINAGE FACILITIES) MY BE REQUIRED WHERE INDICATED.
7. A NOTE FOR FLOOD HAZARD MAY BE REQUIRED WHERE INDICATED ON THIS PLAN.
8. A DRAINAGE BENEFIT ASSESSMENT AREA WILL BE REQUIRED FOR THE MAINTENANCE OF THE PROPOSED DETENTION BASIN AND STORM DRAIN FACILITIES.
9. A SOIL REPORT WILL BE REQUIRED TO VERIFY THAT A 7-DAY PERCOLATION RATE CAN BE OBTAINED.

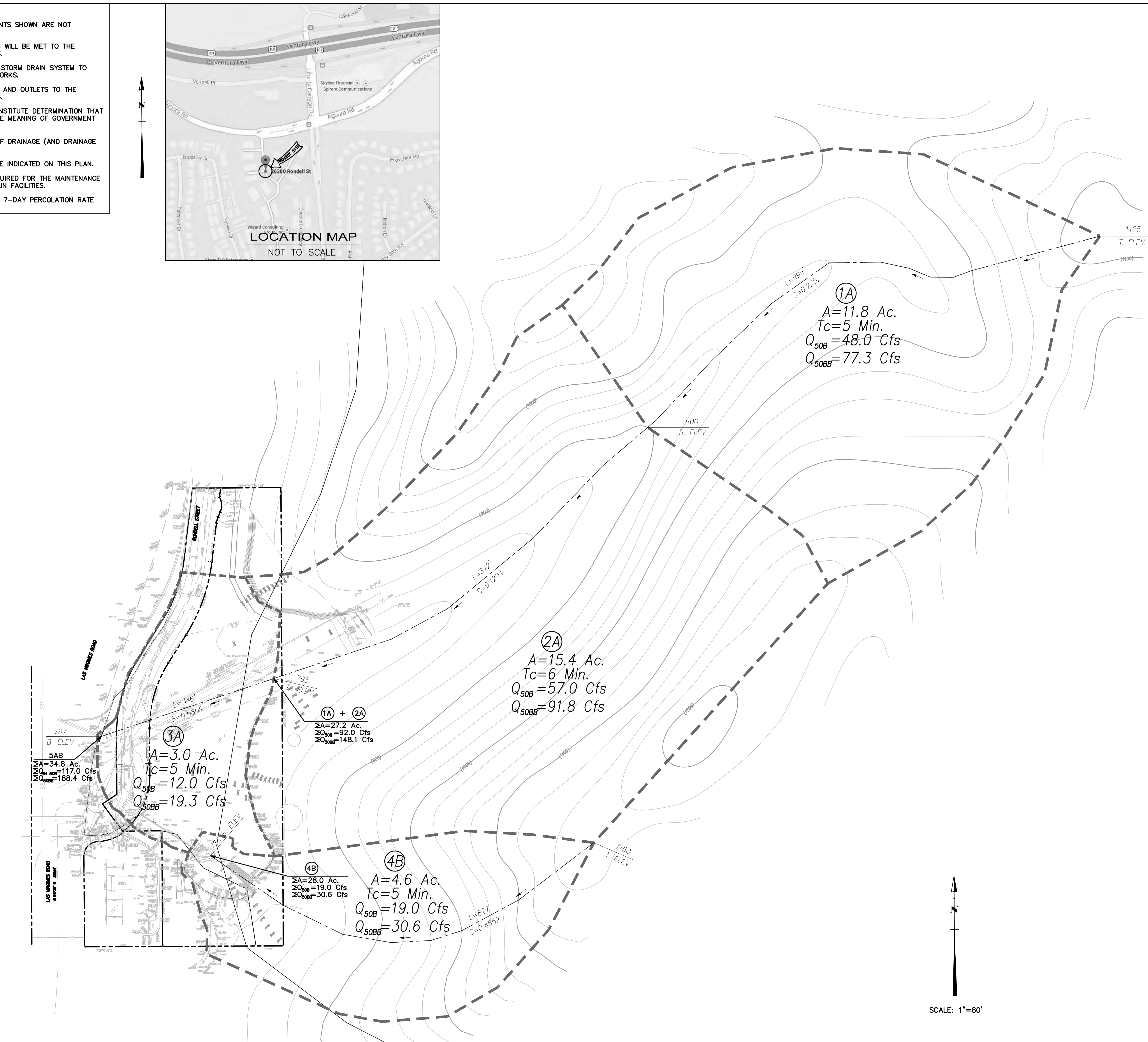
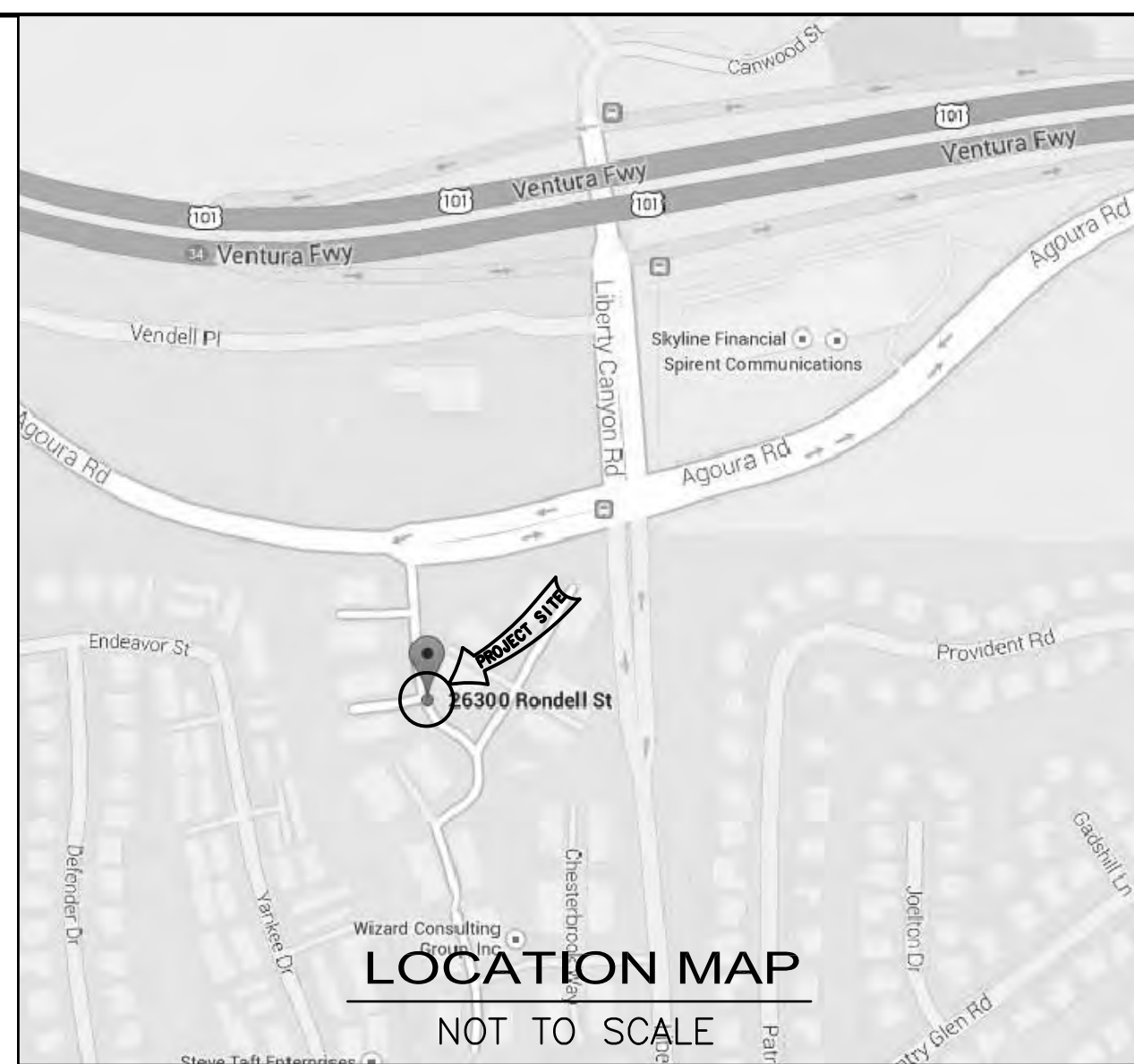

SCALE: 1"=80'

NO.	BY	DATE	SHEET	DESCRIPTION
REVISIONS				
				SPINDLER ENGINEERING CP 18823 SATICOY STREET VAN NUYS, CA 91408 (818) 782-2788 (323) 873-1788 FAX: (818) 782-0111 RONALD W. SPINDLER R.C.E. 13194
CLIENT:				WEINTRAUB FINANCIAL SERVICES, INC. PRE-DEVELOPMENT HYDROLOGY PLAN
PROJECT:				SHEET 1 OF 1

These plans are instruments of service and the property of Spindler Engineering CP. All information contained on these drawings is for use on this specified project. If plans are provided in an electronic format (computer disk, compact disk, or via e-mail or modern transmission, etc) as a courtesy to our client, the delivery of electronic files does not constitute the delivery of our professional work product. Only paper prints signed by a registered engineer employed by Spindler Engineering CP constitute our professional work product. Spindler Engineering CP shall not be responsible for any modifications made to the electronic files, or for any products derived from electronic files which are not reviewed and signed by a registered engineer employed by Spindler Engineering CP.

Copyright: Spindler Engineering CP
All rights Reserved.

Appendix E

Noise Measurements and Modeling Results



File name AU2_0201
 File number 1
 Data number 2
 Frequency-weight A
 Time-weight Fast
 Filter -
 Center/High pass filter cutoff -
 Low pass filter cutoff -
 Time setting 15min
 Start Time 3/6/2015 8:50
 Stop Time 3/6/2015 9:05
 Lx1 L10
 Lx2 L33
 Lx3 L50
 Lx4 L90
 Lx5 L95
 Ly Lppeak

Address	Time	Measurment Time	LAeq	LAE	LAmx	L Amin	LA10	LA33	LA50
1	3/6/2015 8:50	0:15:00	69.2	98.8	79.5	59.1	73.1	68.7	66.9

Address	Time	Measurment Time	LA90	LA95	Lppeak	Over	Under	Pause
1	3/6/2015 8:50	0:15:00	62.6	61.6	106.5	-	-	-

File name AU2_0202
 File number 1
 Data number 2
 Frequency-weight A
 Time-weight Fast
 Filter -
 Center/High pass filter cutoff -
 Low pass filter cutoff -
 Time setting 15min
 Start Time 3/6/2015 9:10
 Stop Time 3/6/2015 9:25
 Lx1 L10
 Lx2 L33
 Lx3 L50
 Lx4 L90
 Lx5 L95
 Ly Lppeak

Address	Time	Measurment Time	LAeq	LAE	LAmx	LAmn	LA10	LA33	LA50
1	3/6/2015 9:10	0:15:00	64.6	94.1	76.1	57	66.6	64.5	63.4

Address	Time	Measurment Time	LA90	LA95	Lppeak	Over	Under	Pause
1	3/6/2015 9:10	0:15:00	60.9	60.3	112	-	-	-

File name AU2_0203
 File number 1
 Data number 2
 Frequency-weight A
 Time-weight Fast
 Filter -
 Center/High pass filter cutoff -
 Low pass filter cutoff -
 Time setting 15min
 Start Time 3/6/2015 9:30
 Stop Time 3/6/2015 9:45
 Lx1 L10
 Lx2 L33
 Lx3 L50
 Lx4 L90
 Lx5 L95
 Ly Lppeak

Address	Time	Measurment Ti	LAeq	LAE	LAmx	L Amin	LA10	LA33
1	3/6/2015 9:30	0:15:00	59.5	89	72	54.2	61.4	59.7

Address	Time	Measurment Ti	LA50	LA90	LA95	Lppeak	Over	Under	Pause
1	3/6/2015 9:30	0:15:00	59	57	56.4	112.4	-	-	-

***** CASE INFORMATION *****

***** Results calculated with TNM Version 2.5 *****

C+P: N of Agoura

***** TRAFFIC VOLUME/SPEED INFORMATION *****

Automobile volume (v/h):	3240.0
Average automobile speed (mph):	35.0
Medium truck volume (v/h):	162.0
Average medium truck speed (mph):	35.0
Heavy truck volume (v/h):	0.0
Average heavy truck speed (mph):	0.0
Bus volume (v/h):	0.0
Average bus speed (mph):	0.0
Motorcycle volume (v/h):	0.0
Average Motorcycle speed (mph):	0.0

***** TERRAIN SURFACE INFORMATION *****

Terrain surface: soft

***** RECEIVER INFORMATION *****

DESCRIPTION OF RECEIVER # 1

Residence

Distance from center of 12-ft wide, single lane roadway (ft): 50.0
A-weighted Hourly Equivalent Sound Level without Barrier (dBA): 69.1

***** CASE INFORMATION *****

***** Results calculated with TNM Version 2.5 *****

C+P: S of Agoura

***** TRAFFIC VOLUME/SPEED INFORMATION *****

Automobile volume (v/h):	1929.0
Average automobile speed (mph):	40.0
Medium truck volume (v/h):	96.4
Average medium truck speed (mph):	40.0
Heavy truck volume (v/h):	0.0
Average heavy truck speed (mph):	0.0
Bus volume (v/h):	0.0
Average bus speed (mph):	0.0
Motorcycle volume (v/h):	0.0
Average Motorcycle speed (mph):	0.0

***** TERRAIN SURFACE INFORMATION *****

Terrain surface: soft

***** RECEIVER INFORMATION *****

DESCRIPTION OF RECEIVER # 1

Residence

Distance from center of 12-ft wide, single lane roadway (ft): 50.0
A-weighted Hourly Equivalent Sound Level without Barrier (dBA): 68.5

***** CASE INFORMATION *****

***** Results calculated with TNM Version 2.5 *****

C+P: West of Las Virgenes

***** TRAFFIC VOLUME/SPEED INFORMATION *****

Automobile volume (v/h):	1271.0
Average automobile speed (mph):	45.0
Medium truck volume (v/h):	63.5
Average medium truck speed (mph):	45.0
Heavy truck volume (v/h):	0.0
Average heavy truck speed (mph):	0.0
Bus volume (v/h):	0.0
Average bus speed (mph):	0.0
Motorcycle volume (v/h):	0.0
Average Motorcycle speed (mph):	0.0

***** TERRAIN SURFACE INFORMATION *****

Terrain surface: soft

***** RECEIVER INFORMATION *****

DESCRIPTION OF RECEIVER # 1

Residence

Distance from center of 12-ft wide, single lane roadway (ft): 50.0
A-weighted Hourly Equivalent Sound Level without Barrier (dBA): 68.1

***** CASE INFORMATION *****

***** Results calculated with TNM Version 2.5 *****

E+P_N of Agoura

***** TRAFFIC VOLUME/SPEED INFORMATION *****

Automobile volume (v/h):	3032.0
Average automobile speed (mph):	35.0
Medium truck volume (v/h):	151.6
Average medium truck speed (mph):	35.0
Heavy truck volume (v/h):	0.0
Average heavy truck speed (mph):	0.0
Bus volume (v/h):	0.0
Average bus speed (mph):	0.0
Motorcycle volume (v/h):	0.0
Average Motorcycle speed (mph):	0.0

***** TERRAIN SURFACE INFORMATION *****

Terrain surface: soft

***** RECEIVER INFORMATION *****

DESCRIPTION OF RECEIVER # 1

Residence

Distance from center of 12-ft wide, single lane roadway (ft): 50.0
A-weighted Hourly Equivalent Sound Level without Barrier (dBA): 68.9

***** CASE INFORMATION *****

***** Results calculated with TNM Version 2.5 *****

E+P: S of Agoura

***** TRAFFIC VOLUME/SPEED INFORMATION *****

Automobile volume (v/h):	1818.0
Average automobile speed (mph):	40.0
Medium truck volume (v/h):	90.9
Average medium truck speed (mph):	40.0
Heavy truck volume (v/h):	0.0
Average heavy truck speed (mph):	0.0
Bus volume (v/h):	0.0
Average bus speed (mph):	0.0
Motorcycle volume (v/h):	0.0
Average Motorcycle speed (mph):	0.0

***** TERRAIN SURFACE INFORMATION *****

Terrain surface: soft

***** RECEIVER INFORMATION *****

DESCRIPTION OF RECEIVER # 1

Residence

Distance from center of 12-ft wide, single lane roadway (ft): 50.0
A-weighted Hourly Equivalent Sound Level without Barrier (dBA): 68.2

***** CASE INFORMATION *****

***** Results calculated with TNM Version 2.5 *****

E+P: W of Las Virgenes

***** TRAFFIC VOLUME/SPEED INFORMATION *****

Automobile volume (v/h):	1174.0
Average automobile speed (mph):	45.0
Medium truck volume (v/h):	58.7
Average medium truck speed (mph):	45.0
Heavy truck volume (v/h):	0.0
Average heavy truck speed (mph):	0.0
Bus volume (v/h):	0.0
Average bus speed (mph):	0.0
Motorcycle volume (v/h):	0.0
Average Motorcycle speed (mph):	0.0

***** TERRAIN SURFACE INFORMATION *****

Terrain surface: soft

***** RECEIVER INFORMATION *****

DESCRIPTION OF RECEIVER # 1

Residence

Distance from center of 12-ft wide, single lane roadway (ft): 50.0
A-weighted Hourly Equivalent Sound Level without Barrier (dBA): 67.8

***** CASE INFORMATION *****

***** Results calculated with TNM Version 2.5 *****

Existing_N of Agoura

***** TRAFFIC VOLUME/SPEED INFORMATION *****

Automobile volume (v/h):	2979.0
Average automobile speed (mph):	35.0
Medium truck volume (v/h):	148.9
Average medium truck speed (mph):	35.0
Heavy truck volume (v/h):	0.0
Average heavy truck speed (mph):	0.0
Bus volume (v/h):	0.0
Average bus speed (mph):	0.0
Motorcycle volume (v/h):	0.0
Average Motorcycle speed (mph):	0.0

***** TERRAIN SURFACE INFORMATION *****

Terrain surface: soft

***** RECEIVER INFORMATION *****

DESCRIPTION OF RECEIVER # 1

Residence

Distance from center of 12-ft wide, single lane roadway (ft): 50.0
A-weighted Hourly Equivalent Sound Level without Barrier (dBA): 68.8

***** CASE INFORMATION *****

***** Results calculated with TNM Version 2.5 *****

Existing: S of Agoura

***** TRAFFIC VOLUME/SPEED INFORMATION *****

Automobile volume (v/h):	1810.0
Average automobile speed (mph):	40.0
Medium truck volume (v/h):	90.5
Average medium truck speed (mph):	40.0
Heavy truck volume (v/h):	0.0
Average heavy truck speed (mph):	0.0
Bus volume (v/h):	0.0
Average bus speed (mph):	0.0
Motorcycle volume (v/h):	0.0
Average Motorcycle speed (mph):	0.0

***** TERRAIN SURFACE INFORMATION *****

Terrain surface: soft

***** RECEIVER INFORMATION *****

DESCRIPTION OF RECEIVER # 1

Residence

Distance from center of 12-ft wide, single lane roadway (ft): 50.0
A-weighted Hourly Equivalent Sound Level without Barrier (dBA): 68.2

***** CASE INFORMATION *****

***** Results calculated with TNM Version 2.5 *****

Existing: W of Las Virgenes

***** TRAFFIC VOLUME/SPEED INFORMATION *****

Automobile volume (v/h):	1162.0
Average automobile speed (mph):	45.0
Medium truck volume (v/h):	58.1
Average medium truck speed (mph):	45.0
Heavy truck volume (v/h):	0.0
Average heavy truck speed (mph):	0.0
Bus volume (v/h):	0.0
Average bus speed (mph):	0.0
Motorcycle volume (v/h):	0.0
Average Motorcycle speed (mph):	0.0

***** TERRAIN SURFACE INFORMATION *****

Terrain surface: soft

***** RECEIVER INFORMATION *****

DESCRIPTION OF RECEIVER # 1

Residence

Distance from center of 12-ft wide, single lane roadway (ft): 50.0
A-weighted Hourly Equivalent Sound Level without Barrier (dBA): 67.7

Appendix F
Traffic Analysis



Overland Traffic Consultants, Inc.

**TRAFFIC IMPACT ANALYSIS FOR
RONDELL OASIS HOTEL
26300 Rondell Street
in the City of Calabasas**



Prepared by:
Overland Traffic Consultants, Inc.
952 Manhattan Beach Bl, #100
Manhattan Beach, California 90266
(310) 545-1235

TRAFFIC IMPACT ANALYSIS FOR
PROPOSED
RONDELL OASIS HOTEL

Located at 26300 Rondell Street
In the City of Calabasas

Prepared by:

Overland Traffic Consultants, Inc.
952 Manhattan Beach Boulevard, #100
Manhattan Beach, CA 90266
(310) 545-1235

December 2014

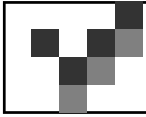

EXECUTIVE SUMMARY

This report documents the results of a study evaluating the potential traffic impacts created by the construction of a 127 room hotel on the east side of Rondell Street east of Las Virgenes Road in the City of Calabasas. The proposed project would be constructed on land that is currently vacant.

As part of the development of the site, Rondell Street will be improved adjacent to the site as directed by the Department of Public Works. Rondell Street will be constructed along the project frontage and terminate at the north end of the site. Vehicular access to the new hotel will be from Rondell Street off of Las Virgenes Road. A portion of the project parking will be provided by new perpendicular parking provided along Rondell Street with the balance up a hill with surface parking at the same level as the hotel. A total of 151 parking spaces are proposed. Rondell Street is the four legged intersection of the southbound on/off ramps of the 101 Freeway, Las Virgenes Road and Rondell Street.

It is estimated that the 127-room hotel would generate an increase of 1,038 vehicle trips daily with 67 new trips during the morning peak hour and 76 trips during the evening peak hour.

Using the criteria established by the City of Calabasas, 2030 General Plan, December 2008 it has been determined that the added traffic volume generated by the project will not significantly impact any of the five study intersections.

Parking - The project will provide in excess of City of Calabasas code required parking for the hotel. No parking impacts are anticipated.

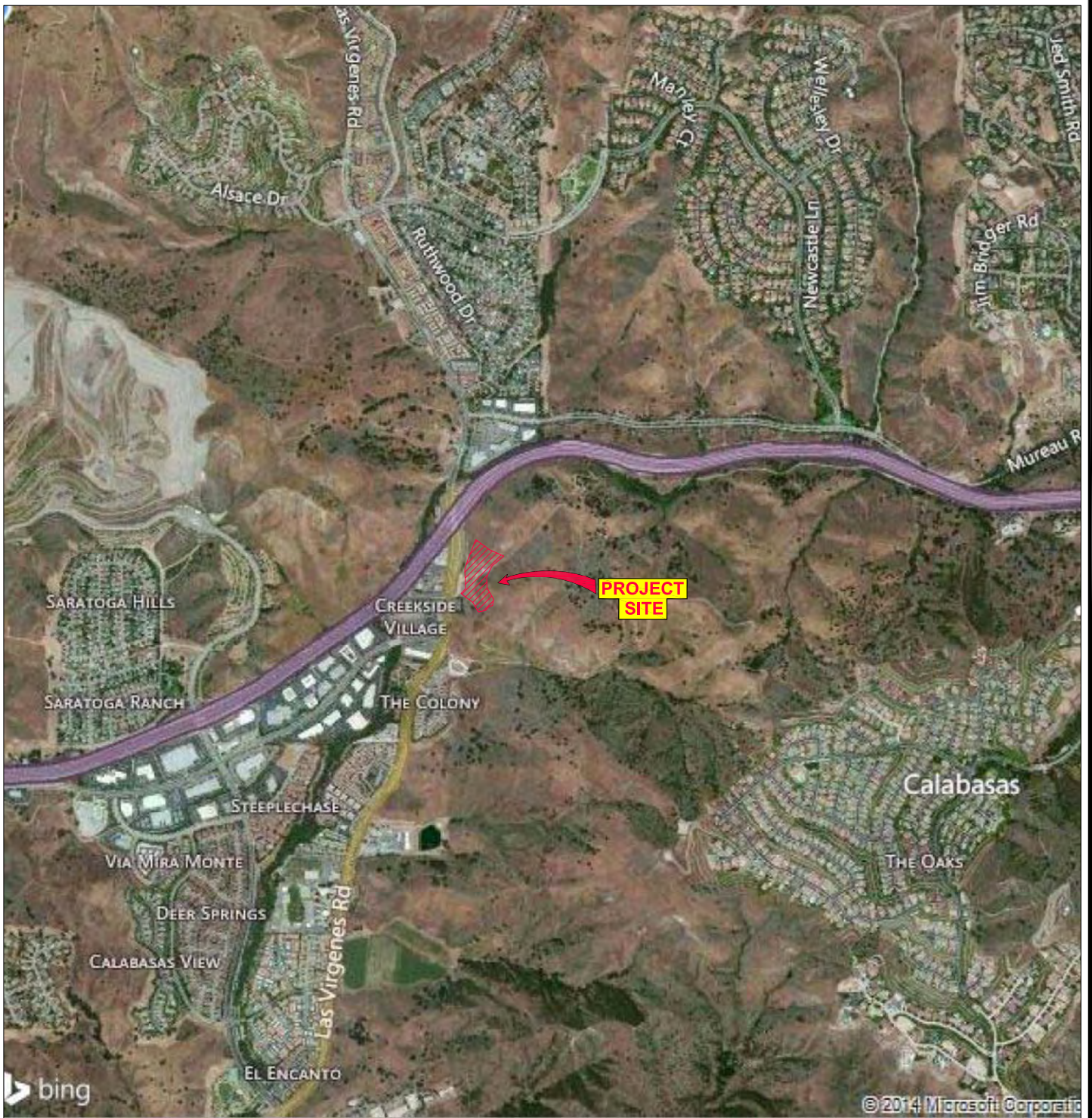

9/2014

PROJECT SETTING

 **Overland Traffic Consultants, Inc.**
952 Manhattan Beach Bl, #100, Manhattan Beach, CA 90266
(310) 545-1235 phone, liz@overlandtraffic.com



TABLE OF CONTENTS

Chapter 1 – Introduction.....	1
Chapter 2 - Project Description	3
Chapter 3 - Environmental Setting	6
Land Use	6
Transportation Facilities.....	6
Transit Information.....	9
Chapter 4 - Project Traffic Characteristics.....	10
Project Traffic Generation	10
Traffic Distribution and Assignment of Project Traffic	11
Parking, Access and Circulation	15
Chapter 5 - Traffic Conditions Analysis	16
Analysis of Existing Traffic Conditions	16
Significant Traffic Impact Definition.....	21
Analysis of Existing + Project Traffic Conditions	22
Analysis of Future Traffic Conditions	23
Bicycle Service Evaluation.....	33
Transit Evaluation	35
Impacts on Regional Transportation System	36
Chapter 6 – Mitigation Measures	38
Appendix A – Community Plan Land Use Information	
Appendix B – Street Designations & Aerial Photos of Intersections	
Appendix C – Transit Routes	
Appendix D – Traffic Volume Data	
Appendix E – Related Project Trip Generation	
Appendix F – Bicycle Plan Maps	
Appendix G – ICU Worksheets	



LIST OF FIGURES

Figure 1	Project Location	4
Figure 2	Project Site Plan	5
Figure 3	Study Intersection Characteristics.....	7
Figure 4	Project Traffic Distribution	12
Figure 5	Project Traffic Assignment Percentages	13
Figure 6	Project Traffic - AM & PM Peak Hour.....	14
Figure 7	Existing (2014) Traffic Volume - AM Peak Hour	17
Figure 8	Existing (2014) Traffic Volume - PM Peak Hour	18
Figure 9	Location of Related Projects	25
Figure 10	Related Project Only Traffic Volumes.....	26
Figure 11	Future 2016 Cumulative Traffic Volume (Without Project)–AM Peak Hour	27
Figure 12	Future 2016 Cumulative Traffic Volume (Without Project) - PM Peak Hour	28
Figure 13	Future 2016 Traffic Volume (With Project) – AM Peak Hour	31
Figure 14	Future 2016 Traffic Volume (With Project) – PM Peak Hour	32



LIST OF TABLES

Table 1	Project Trip Generation Rates	10
Table 2	Project Traffic Generation	10
Table 3	Parking Requirements	15
Table 4	Level of Service Definitions.....	19
Table 5	Existing (2014) Traffic Conditions Summary	20
Table 6	Significant Impact Criteria	21
Table 7	Existing + Project Traffic Conditions Summary	22
Table 8	Related Projects Descriptions.....	24
Table 9	Future 2016 Cumulative Traffic Conditions Without Project.....	29
Table 10	Future 2016 Traffic Conditions With Project	30
Table 11	Bicycle Parking Requirements	34
Table 12	Transit Trips.....	35
Table 13	Freeway Analysis.....	37



CHAPTER 1

INTRODUCTION

As part of the project's environmental review for the proposed Rondell Oasis Hotel, an evaluation of the potential traffic impacts of the proposed development on the surrounding area is required. Therefore, the traffic impact analyses in this traffic study have been conducted using the procedures adopted by the City of Calabasas to analyze the potential traffic impact of development projects. The intersections of non-freeway ramp locations were evaluated using the Intersection Capacity Utilization (ICU) process. The ICU method calculates the operating conditions of each individual study intersection using a ratio of peak hour traffic volume to the intersection's lane capacity. Any change to the intersection's peak hour operating conditions caused by an increase/decrease in traffic volume can be quantified using this analysis method to show the traffic impact of a proposed project. The intersections of freeway ramp locations were evaluated using the Highway Capacity Manual (HCM) pursuant to the Caltrans' guide for Preparation of Traffic Impact Studies, December 2002. Synchro 8 software was used to conduct the HCM analysis.

Potential traffic impacts caused by a development project that exceed limits established by the City of Calabasas as specified in City's Circulation Element of the 2030 General Plan. Any significantly impacted intersections are then evaluated for possible traffic mitigation measures.

Pursuant to the City of Calabasas, the following steps have been taken to develop the future traffic volume estimate:

- (a) Traffic counts 2014 existing;
- (b) Existing 2014 traffic + the proposed project traffic;
- (c) Traffic in (b) plus recommended traffic mitigation, if necessary;
- (d) Base year 2014 plus ambient growth to 2016 (added additional 1% per year) plus related projects (future "cumulative without project" scenario);



- (e) Traffic in (d) plus the proposed project traffic (future “with project” scenario);
- (f) Traffic in (e) plus recommended traffic mitigation, if necessary.

The ambient growth rate used for the project was based on Southern California Association of Governments (SCAG) Profile of the City of Calabasas dated May 2013. Growth between years 2000 and 2012 was 10.9% which equates to an average of 0.91% per year ($10.9\%/12\text{years} = 0.91\%/year$). This was rounded to 1% per year.

An ICU or HCM analysis of the existing and future traffic conditions analysis has been completed at those locations expected to have the highest potential for significant traffic impacts. Morning and evening peak hour conditions have been evaluated at five (5) key intersections approved by City of Calabasas for review. The intersections most likely to be affected by the new hotel project were selected for analysis. It should be noted that future traffic conditions include the potential construction of the development of six other land development projects in the general vicinity of the project site.

The intersections analyzed in this study are:

1. Las Virgenes Road & Mureau Road;
2. Las Virgenes Road & Southbound 101 Freeway Ramps;
3. Las Virgenes Road & Northbound 101 Freeway Ramps/Rondell Street;
4. Las Virgenes Road & Agoura Road; and,
5. Lost Hills Road & Agoura Road.

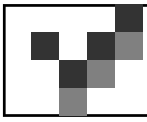

CHAPTER 2

PROJECT DESCRIPTION

The Rondell Oasis Hotel site is proposed to be located on the southeast side of Rondell Street east of Las Virgenes Road. Rondell Street is currently a short access road that provides a secondary vehicular access point for the neighboring gas station with a gated dirt road beyond. The project proposes a four story hotel with 23 rooms on the ground floor and 35 rooms on the second and third floor and 34 rooms on the 4th floor for a total of 127 hotel rooms. The hotel will provide a lounge area, exercise room, and food service and outdoor pool for use by guests of the hotel on the first floor. The project site is currently vacant.

As part of the development of the site, Rondell Street will be improved adjacent to the site as directed by the Department of Public Works. Rondell Street will be constructed along the project frontage and terminate at the north end of the site. The hotel will provide 151 parking spaces for the project. Rondell Street will be paved beyond the current terminus. Parking will be provided on both sides of Rondell Street with parking spaces perpendicular to the street curb. No other projects or parking are provided beyond the hotel property. Additional parking will be provided from a surface lot with two access ways off of Rondell Street up a hill to grade level with the hotel. A porte cochere will be provided at the main entry to the hotel for the guests. Additionally a fire access road will be provided on the south side of the hotel. Access will be from Rondell Street off of Las Virgenes Road. The location of the project is depicted on Figure 1.

Figure 2 illustrates the proposed project site plan.

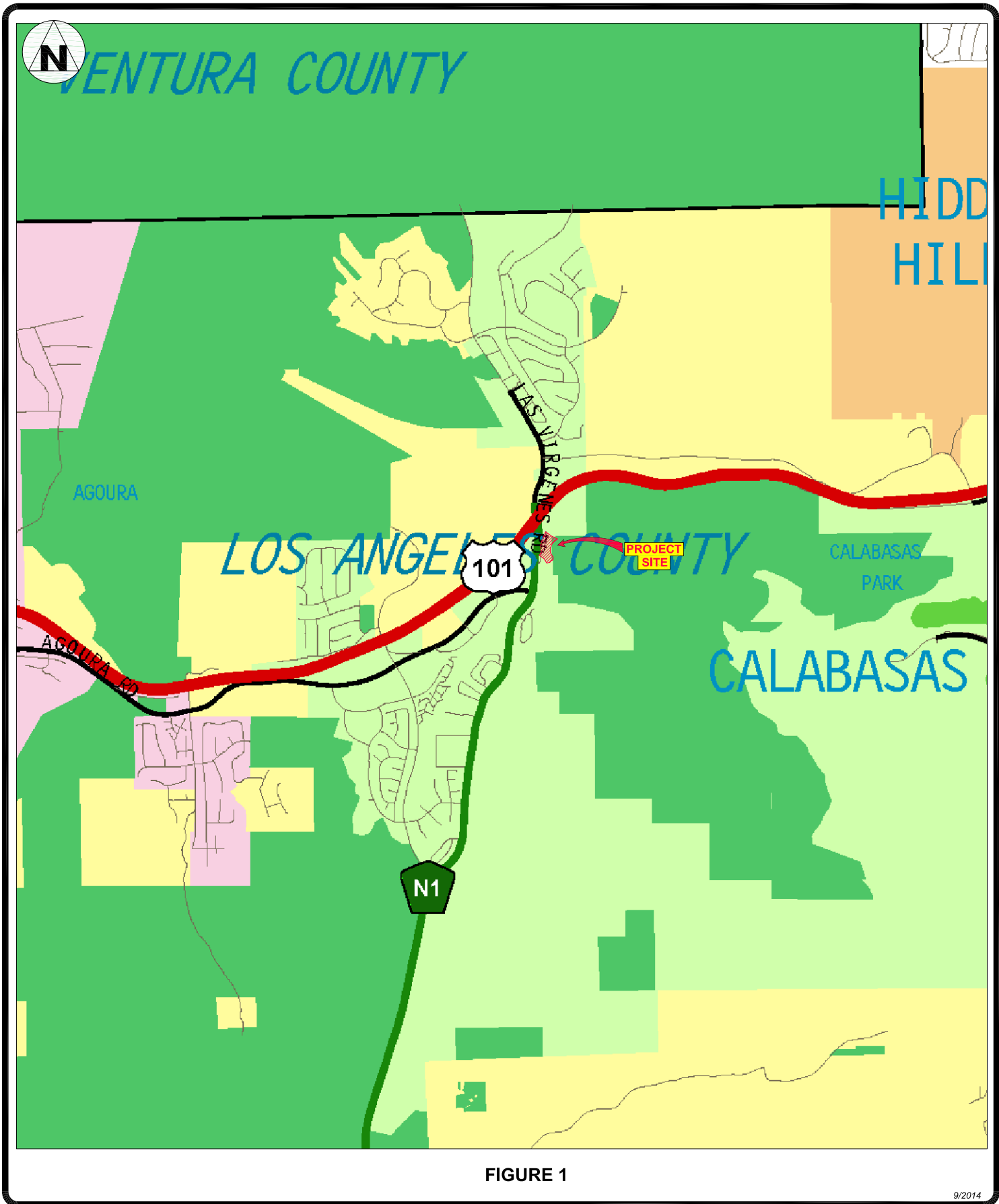

PROJECT LOCATION

Overland Traffic Consultants, Inc.
 952 Manhattan Beach Bl, #100, Manhattan Beach, CA 90266
 (310) 545-1235 phone, liz@overlandtraffic.com

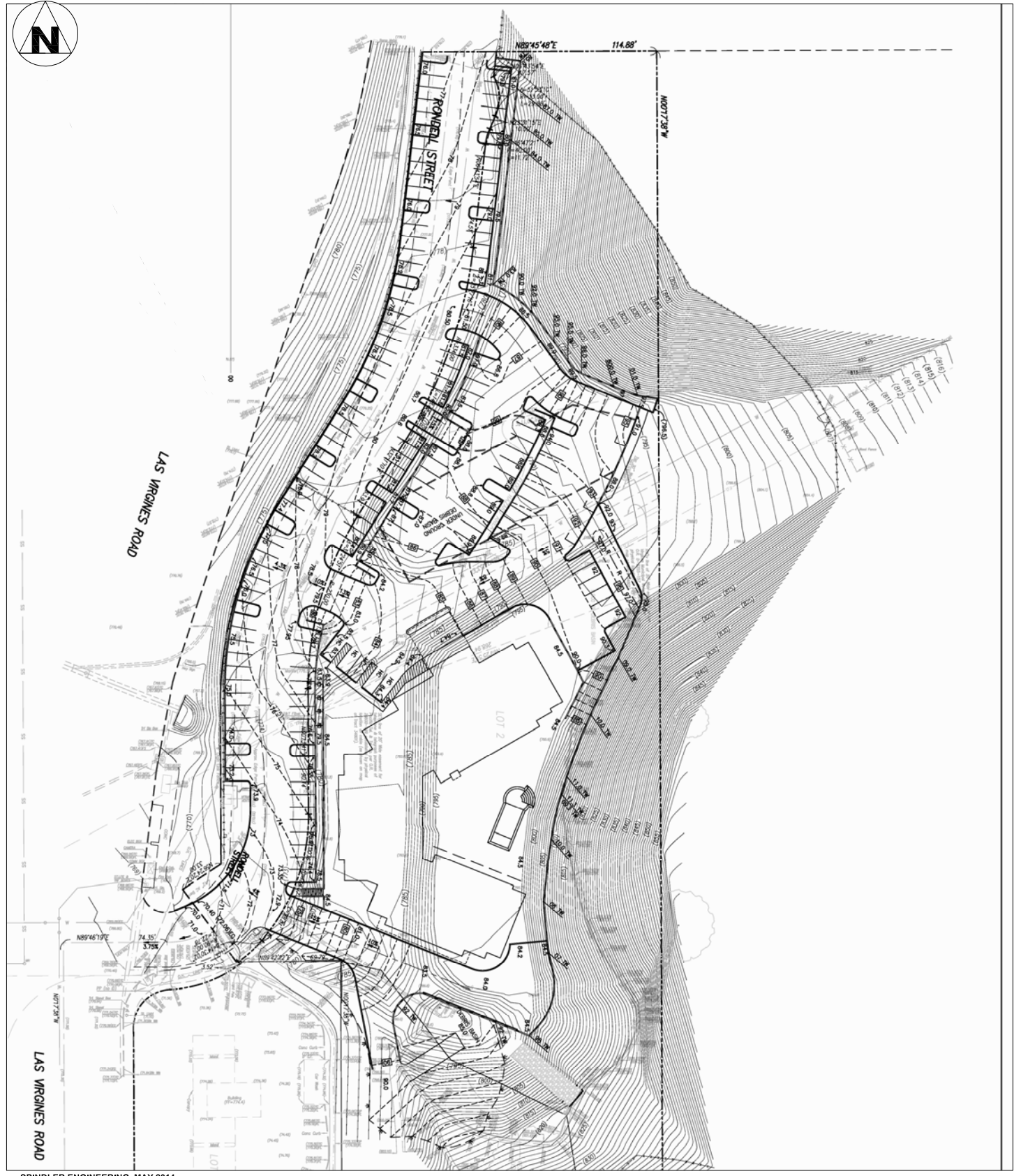

SPINDLER ENGINEERING, MAY 2014

FIGURE 2

10/2014

PROJECT SITE PLAN

 Overland Traffic Consultants, Inc.

952 Manhattan Beach Bl, #100, Manhattan Beach, CA 90266
(310) 545-1235 phone, liz@overlandtraffic.com



CHAPTER 3

ENVIRONMENTAL SETTING

Land Use

The project is located in the northeast area of the City of Calabasas along the Ventura Freeway (State Route 101) corridor. The surrounding area includes existing commercial along Las Virgenes Road, to the south is an existing gas station and the Ventura Freeway located to the northwest. The City's land use plan is provided in Appendix A.

Transportation Facilities

In addition to collecting traffic volume data, field surveys were conducted to determine the roadway and intersection geometry and traffic signal operations. Figure 3 illustrates the study locations, type of intersection traffic control and lane configurations. The study intersection aerial plans are contained in Appendix B. The nearest regional transportation system facility serving the site is the Ventura Freeway. A brief description of the nearby freeway and adjacent roadways is provided below.

The Ventura Freeway (SR-101) operates predominately in the north-south direction but is essentially operating in the east-west direction in the project area. The freeway provides four mixed-flow lanes plus an auxiliary lane in each direction between Lost Hills Road and Las Virgenes Road. Project access to the freeway is provided by ramps located on Las Virgenes Road.

Average daily traffic volume on the Ventura Freeway at Las Virgenes Road is approximately 192,500 vehicles per day (VPD) with 14,700 vehicles per hour southbound during the morning peak hours and 14,300 vehicles per hour northbound during the evening peak hours. Freeway capacity is typically 2,000 vehicles per hour per lane. Using this capacity, the 101 Freeway is operating over capacity in the peak directions during commuter peak hours.

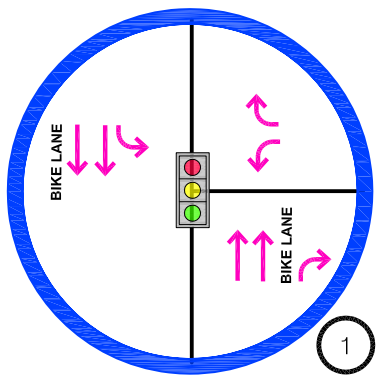

Las Virgenes Rd & Mureau Rd

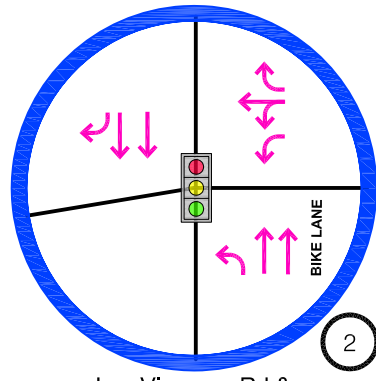

Las Virgenes Rd & NB (WB) 101 Freeway Ramps

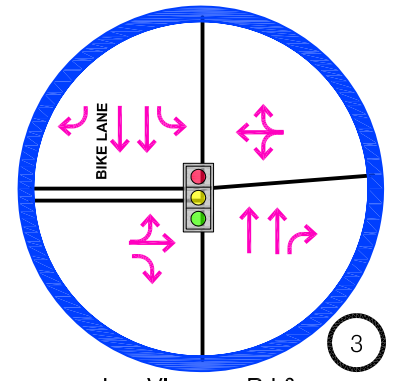

Las Virgenes Rd & SB (EB) 101 Freeway Ramps/Rondell St

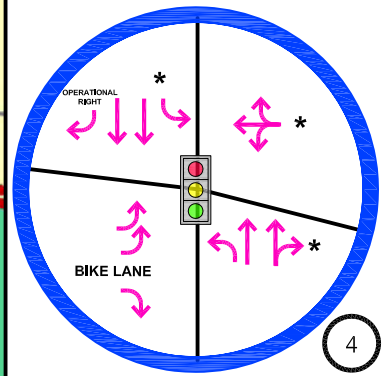

Las Virgenes Rd & Agoura Rd

* Future lane with cumulative project proposed (not this project)

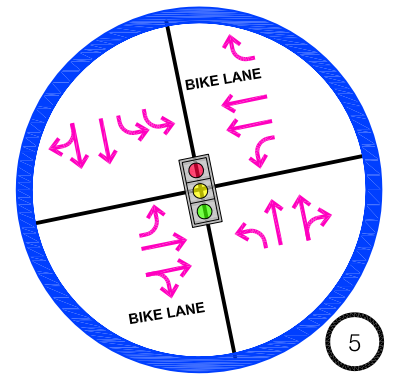

Lost Hills Rd & Agoura Rd

FIGURE 3

9/2014



Agoura Road is an east-west major roadway located south of the freeway. The roadway begins at Las Virgenes Road and extends westerly through the cities of Agoura Hills, Westlake Village to Thousand Oaks. In the vicinity of the project site, Agoura Road currently provides two lanes in each direction with a left-turn median lane and bike lanes. The roadway is posted for a 45 MPH speed limit and provides on-street parking.

Las Virgenes Road is designated as a north-south major arterial in the Circulation Element of the City of Calabasas 2030 General Plan. The road provides access between Calabasas and the Malibu area. South of Mulholland Highway, Las Virgenes Road changes its name to Malibu Canyon Road. Las Virgenes Road terminates approximately 1 ½ miles north of the 101 Freeway.

Lost Hills Road is designated as a north-south major arterial in the Circulation Element of the City of Calabasas 2030 General Plan. The road provides two lanes in each direction in the project vicinity with access from approximately one half mile north of the Ventura Freeway where the road terminates to Las Virgenes Road south of El Encanto Drive.

Mureau Road is designated as a north-south major arterial in the Circulation Element of the City of Calabasas 2030 General Plan. The road provides access between Las Virgenes Road and Calabasas Road with two lanes in each direction.

Rondell Street is currently a short segment of road that provides secondary access to a gas station, is dirt beyond the gas station and used as a small parking lot. It appears that this parking area is being used for commuter parking on weekdays. The road is gated beyond the area used for parking.



Overland Traffic Consultants, Inc.

Transit Information

Public transportation in the study area is provided by the City of Calabasas, Metropolitan Transportation Authority (Metro) and the City of Los Angeles Department of Transportation (LADOT). Calabasas Public Transportation provides shuttle service via routes 1, 2, and 5, and trolley service. Line 1 operates throughout the City of Calabasas seven days a week. Metro provides transit service between Warner Center and the Thousand Oaks Transit Center via Route 161 with direct service to the site as it travels along Las Virgenes Road. LADOT provides the Commuter Express line 423 connecting the cities of Newbury Park, Thousand Oaks, Agoura Hills, Calabasas, Woodland Hills and Encino with downtown Los Angeles. An existing transit stop is provided directly in front of the project site on the north east side of the intersection of Las Virgenes Road and Rondell Street. Transit facilities include a bench, shade cover, transit signs and trash receptacle. Transit service maps are illustrated in Appendix C.

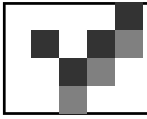

CHAPTER 4

PROJECT TRAFFIC CHARACTERISTICS

Project Traffic Generation

Traffic-generating characteristics of many land uses including the proposed hotel have been surveyed by the Institute of Transportation Engineers (ITE). The results of the traffic generation studies have been published in a handbook titled Trip Generation, 9th Edition. This publication of traffic generation data has become the industry standard for estimating traffic generation for different land uses.

The ITE publication provides trip generation estimates for a hotel. A hotel is described as a place of lodging with supporting facilities such as restaurants, cocktail lounges, meeting and banquet rooms or convention faculties including limited recreational faculties and/or retail shops for the guests use. The proposed Rondell Oasis Hotel will incorporate a restaurant and recreational facilities for the use of the guests. The ITE studies indicate that the proposed hotel generally exhibits the trip-making characteristics as shown by the trip rates in Table 1.

Table 1
Project Traffic Generation Rates

<u>Description</u>	<u>ITE Code</u>	<u>Daily</u>	<u>AM Peak Hour</u>			<u>PM Peak Hour</u>		
			<u>Total</u>	<u>In</u>	<u>Out</u>	<u>Total</u>	<u>In</u>	<u>Out</u>
Hotel	310	8.17	0.53	59%	41%	0.60	51%	49%

Rates are per room for hotel

The new trips associated with the proposed hotel are presented in Table 2.

Table 2
Estimated Project Traffic Generation

<u>ITE Code</u>	<u>Description</u>	<u>Size</u>	<u>Daily</u>	<u>AM Peak Hour</u>			<u>PM Peak Hour</u>		
				<u>Total</u>	<u>In</u>	<u>Out</u>	<u>Total</u>	<u>In</u>	<u>Out</u>
310	Hotel	127 Rooms	1,038	67	40	27	76	39	37

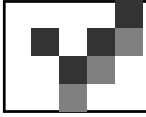

Trip Distribution and Assignment of Project Traffic

A primary factor affecting trip direction is the spatial distribution of population centers and business and entertainment venues which would generate project visitors and employees' trip origins and destinations. The estimated project directional trip distribution is also based on the study area roadway network, traffic flow patterns in and out of this area of the City of Calabasas and consistency with previously approved traffic studies for this area.

Figure 4 illustrates the estimated area wide project traffic distribution percentages. Figure 5 shows the estimated project traffic percentages detailed at each of the selected study intersections. Using the traffic assignment at each intersection and the estimated peak hour traffic volume as provided in the Table 2, peak hour traffic volumes at each study locations has been calculated and are shown in Figure 6 for the new hotel. This estimated assignment of the project traffic flow provides the information necessary to analyze the potential traffic impacts generated by the project at the study intersections.



FIGURE 4

11/2014

OVERALL PROJECT DISTRIBUTION



952 Manhattan Beach Bl, #100, Manhattan Beach, CA 90266
(310) 545-1235 phone, liz@overlandtraffic.com

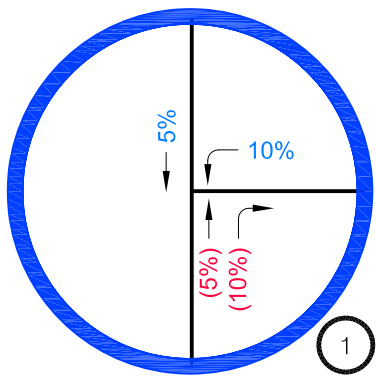

Las Virgenes Rd & Mureau Rd

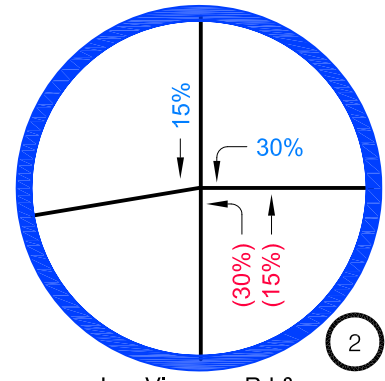

Las Virgenes Rd & NB (WB) 101 Freeway Ramps

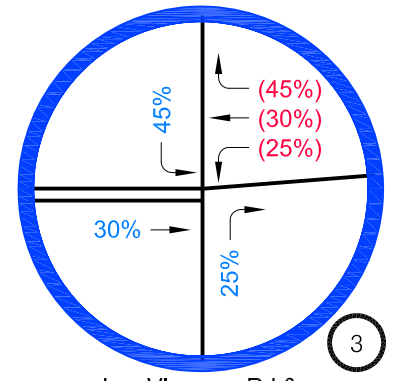

Las Virgenes Rd & SB (EB) 101 Freeway Ramps/Rondell St

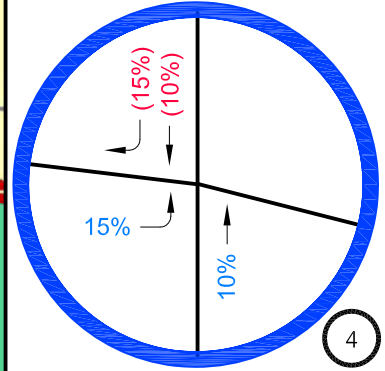

Las Virgenes Rd & Agoura Rd

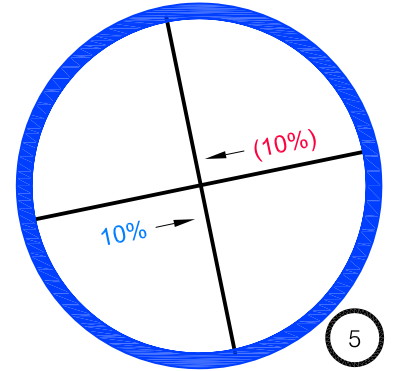

Lost Hills Rd & Agoura Rd

access distribution

LEGEND
 XX INBOUND
 XX OUTBOUND

FIGURE 5

11/2014

PROJECT DISTRIBUTION PERCENTAGES AT STUDY INTERSECTIONS

Overland Traffic Consultants, Inc.
 952 Manhattan Beach Bl #100, Manhattan Beach Ca 90266
 (310)766-5222, (661)799-8423, liz@overlandtraffic.com

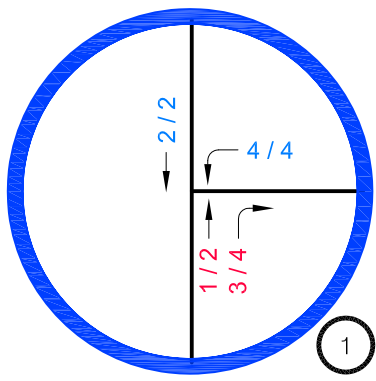

Las Virgenes Rd & Mureau Rd

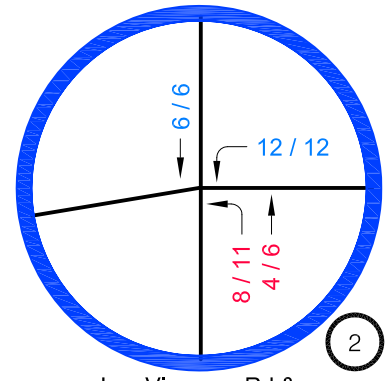

Las Virgenes Rd & NB (WB) 101 Freeway Ramps

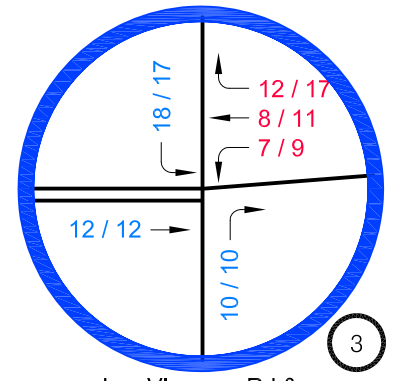

Las Virgenes Rd & SB (EB) 101 Freeway Ramps/Rondell St

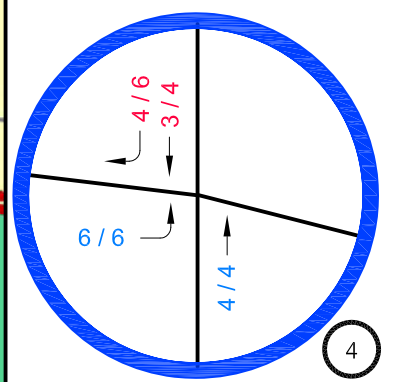

Las Virgenes Rd & Agoura Rd

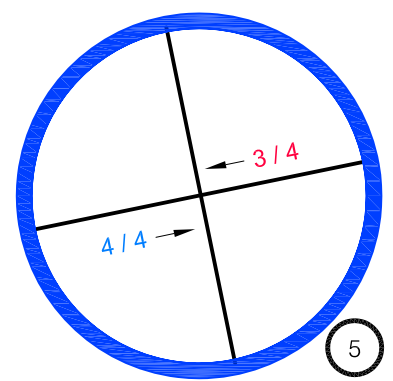

Lost Hills Rd & Agoura Rd

access distribution

LEGEND
 XX INBOUND
 XX OUTBOUND

FIGURE 6

11/2014

PROJECT TRIPS ONLY
 AM PEAK HOUR/PM PEAK HOUR

Overland Traffic Consultants, Inc.
 952 Manhattan Beach Bl #100, Manhattan Beach Ca 90266
 (310)766-5222, (661)799-8423, liz@overlandtraffic.com



Parking, Access & Circulation

The proposed parking lot for the Rondell Oasis Hotel is to be provided with surface parking on grade with the hotel and perpendicular parking along the portion of Rondell Street that will be constructed as part of this project. The lot that is on grade with the hotel will be accessible from two access ways off of Rondell Street. A porte cochere will be provided at the entry to the hotel.

Rondell Street currently exists as a short segment transitioning to a dirt road that is gated. Rondell Street provides secondary access to a gas station and a dirt lot used currently used for parking. Rondell Street connects to Las Virgenes Road across from the Southbound 101 Freeway ramps. This intersection is signalized. Full access will be provided to and from the site at this intersection.

A total of 151 parking spaces are proposed for the new hotel project. According to City of Calabasas Municipal Code Requirements 17.28.040, hotel vehicle parking shall be provided with one parking space per hotel room plus one additional space per ten hotel rooms. Table 3 displays the project parking requirements for a total of 140 parking spaces.

Table 3
City Vehicle Parking Requirements for Hotel

Land Use	Size	Vehicle Parking Requirement	Number of Required Spaces	Number of Provided Spaces
Hotel	127 rooms	1 space per room + 1 space per 10 rooms	127 13	
TOTAL			140	151

The project site will provide 11 more vehicle parking spaces than required by City code.

No parking impacts are anticipated for this project.



Analysis of Existing Traffic Conditions

Traffic volume data used in the following peak hour intersectional analysis were based on traffic counts conducted by National Data Systems an independent traffic data collection company. Traffic counts were conducted on Thursday, September 11, 2014 a typical weekday when there were no holidays and schools were in session.

Existing peak hour traffic volumes at the study intersections are illustrated in Figure 7 for the morning rush hour and Figure 8 for the evening rush hour. Data collection worksheets for the peak hour counts are contained in Appendix D.

The traffic conditions analysis was conducted using the Intersection Capacity Utilization (ICU) method at the non freeway interchange locations. The study intersections were evaluated using this methodology pursuant to the criteria established by the City of Calabasas for signalized intersections. The ICU technique compares the volume and capacity of an intersection. The existing peak hour traffic counts were used along with intersection lane configurations and traffic controls to determine the intersection's current operating condition.

ICU analysis consist of determining the amount of signal time needed to serve each conflicting traffic movement, adding the times for movements and comparing the total time available. The available capacity for key movements is directly related to traffic demand. The capacity per hour of green time for each approach is calculated based upon Highway Capacity Manual methodology at signalized locations. A lane capacity of 1,600 vehicles per hour per lane (reduced to 2,880 vehicles per hour for dual left turn lanes) and 10% yellow clearance time were used. To calculate capacity, the proportion of total signal time needed by key traffic movement is determined and compared to the total available time. The key movements are the opposing movements whose combined green time demands are the greatest, and the conflicting key movements are added and expressed as a decimal fraction.

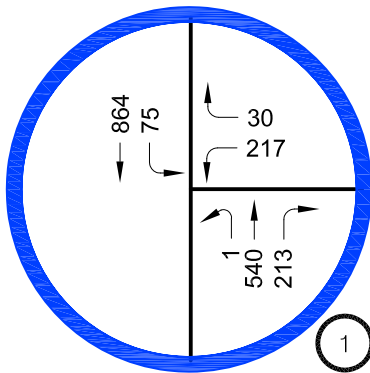

Las Virgenes Rd & Mureau Rd

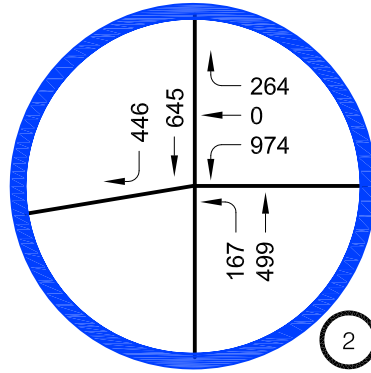

Las Virgenes Rd & NB (WB) 101 Freeway Ramps

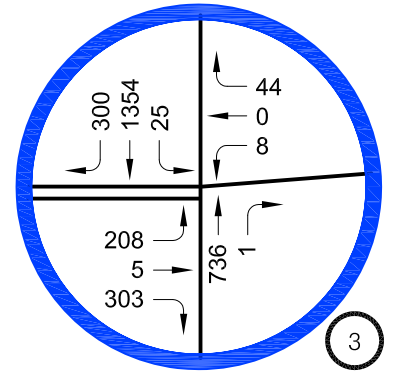

Las Virgenes Rd & SB (EB) 101 Freeway Ramps/Rondell St

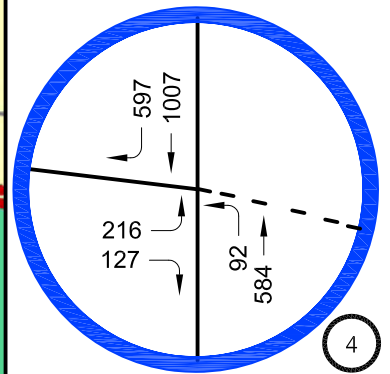

Las Virgenes Rd & Agoura Rd

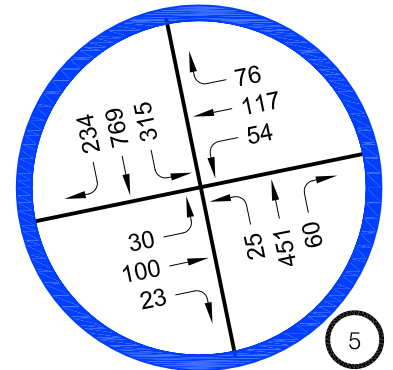

Lost Hills Rd & Agoura Rd

FIGURE 7

9/2014

**EXISTING (2014) TRAFFIC VOLUMES
AM PEAK HOUR**

Overland Traffic Consultants, Inc.

952 Manhattan Beach Bl #100, Manhattan Beach Ca 90266
(310)766-5222, (661)799-8423, liz@overlandtraffic.com

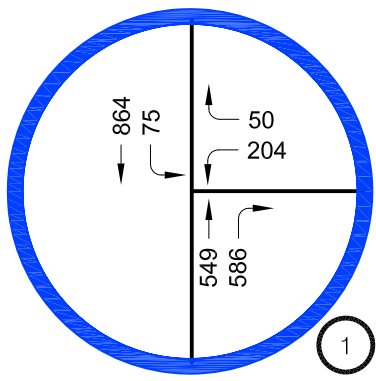

Las Virgenes Rd & Mureau Rd

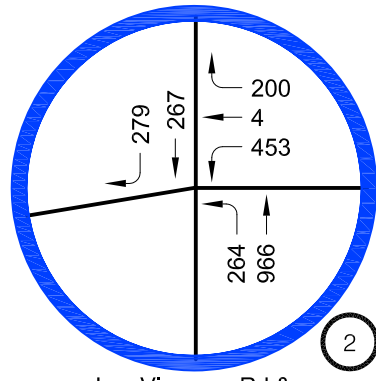

Las Virgenes Rd & NB (WB) 101 Freeway Ramps

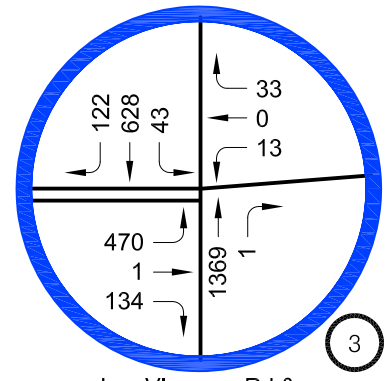

Las Virgenes Rd & SB (EB) 101 Freeway Ramps/Rondell St

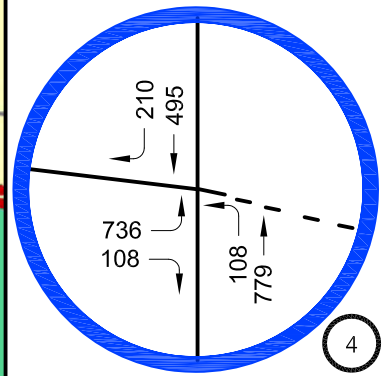

Las Virgenes Rd & Agoura Rd

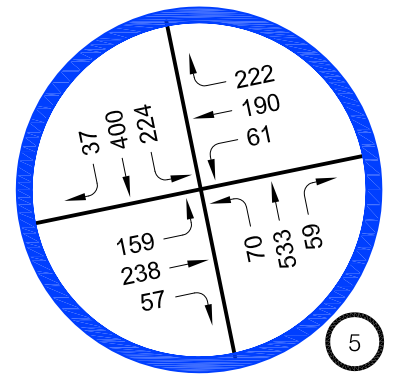

Lost Hills Rd & Agoura Rd

FIGURE 8

9/2014

**EXISTING (2014) TRAFFIC VOLUMES
PM PEAK HOUR**

Overland Traffic Consultants, Inc.
 952 Manhattan Beach Bl #100, Manhattan Beach Ca 90266
 (310)766-5222, (661)799-8423, liz@overlandtraffic.com

There resulting ICU displays the proportion of the total hour required to meet the intersection demand volumes in the key conflicting traffic movements.

The HCM method uses control daily to determine the Level of Service. Capacity of a movement or lane group is measured based on the green period to cycle length ratio multiplied by the saturation flow rate (1,900 passenger cars per hour per lane) for the movement lane group.

Once the ICU and HCM value has been calculated, operating characteristics are assigned a level of service grade (A through F) to estimate the level of congestion and stability of the traffic flow. The term "Level of Service" (LOS) is used by traffic engineers to describe the quality of traffic flow. Definitions of the LOS grades as indicated in the City Of Calabasas Circulation Element of the General Plan are shown in Table 4 for ICU volume to capacity and HCM delay in seconds per vehicle.

Table 4
Level of Service Definitions

LOS	ICU Value (volume/capacity)	HCM Value* Delay	Operating Conditions
A	0.00 – 0.60	≤ 10 sec	Progression is extremely favorable. Most vehicles arrive during the green phase. Many vehicles do not stop at all.
B	>0.60 – 0.70	10-20 sec	Good progression, short cycle lengths, or both. More vehicles stop than with LOS A, causing higher levels of delay.
C	>0.70 – 0.80	20-35 sec	Only fair progression, longer cycle lengths, or both. Cycle lengths may fail to serve queued vehicles, and overflow occurs. Number of vehicles stopped is significant, though many may still pass through intersection without stopping.
D	>0.80 – 0.90	35-55 sec	Congestion becomes more noticeable. Unfavorable progression, long cycle lengths and high v/c ratios result in longer delays. Many vehicles stop, and the proportion of vehicles not stopping declines. Individual cycle failures are noticeable.
E	>0.90 – 1.00	55-80 sec	High delay values indicate poor progression, long cycle lengths and high v/c ratios. Individual cycle failures are frequent.
F	>1.00	≥ 80 sec	Considered unacceptable for most drivers, this level occurs when arrival flow rates exceed the capacity of lane groups, resulting in many individual cycle failures. Poor progression and long cycle lengths may also contribute to high delay levels.

* Signalized locations, sec = seconds



By applying these procedures to the intersection data, the ICU and HCM values (Delay) and corresponding LOS for the existing traffic conditions were determined for each intersection.

The ICU/Delay and LOS valuated are summarized in Table 5. Supporting analysis worksheets are contained in Appendix G of this report.

Table 5
Level of Service for Existing (2014) Conditions

<u>No.</u>	<u>Intersection</u>	<u>Peak Hour</u>	<u>Existing</u>	
			<u>ICU/Delay</u>	<u>LOS</u>
1	Las Virgenes Rd & Mureau Rd	AM	0.506	A
		PM	0.641	B
2	<i>Las Virgenes Rd & NB (WB) 101 Freeway Ramps</i>	AM	24.0	C
		PM	18.7	B
3	<i>Las Virgenes Rd & SB (EB) 101 Fwy Ramps/Rondell</i>	AM	11.5	B
		PM	21.1	C
4	Las Virgenes Rd & Agoura Rd	AM	0.610	B
		PM	0.599	A
5	Los Hills Road & Agoura Rd	AM	0.501	A
		PM	0.601	B

Intersectons 1, 4 and 5 are analyzed using ICU volume/capacity

Intersections 2 & 4 are analyzed using HCM Delay seconds per vehicle

As shown in Table 5, all the study intersections are operating at LOS C or better during the morning and evening peak hours.

Significant Impact Definition

Comparing the changes in traffic conditions between existing conditions and existing + project provides the necessary information to determine if the added traffic volume creates a significant impact on the study intersections with conditions. According to standards adopted by the City of Calabasas Circulation Element of the General Plan 2030 an impact is identified as significant under the following conditions:

The minimum acceptable LOS at an intersection is LOS C except at freeway interchanges and the two lane segment of Calabasas Road that traverses Old Town Calabasas. The performance level for the interchange locations is LOS D and the Old Town Calabasas section of Calabasas Road is LOS F.

The City of Calabasas has developed policies to address potential traffic impacts created by new development. Policy VI-2 states a need to limit the intensity and traffic generation of new development in the City to that which would compromise attainment of the maintenance of roadway level of service standards indicated above. Policy VI-3 states that where existing or projected traffic volumes at General Plan buildout prevent a project from complying with VI-2, the development should be limited in intensity during the peak hours to not exceed the criteria displayed in Table 6.

Table 6
Criteria for Significant Traffic Impact

<u>LOS</u>	<u>Final ICU Value</u>	<u>Project-related increase in ICU value</u>
D	0.81 - 0.90	+ 0.020
E	0.91 – 1.00	+ 0.015
F	> 1.00	+ 0.010 or more

Exceeding these limits is defined as a significant traffic impact and mitigation would be required to reduce the level of impact below these thresholds.

Analysis of Existing + Project Conditions

An evaluation has been conducted to evaluate potential project impacts to the existing conditions. This has been done by adding the project traffic to the existing traffic volumes. As noted below in Table 7, no significant traffic project impacts occur.

Table 7
Traffic Conditions for Existing + Project

<u>No.</u>	<u>Intersection</u>	<u>Peak Hour</u>	<u>Existing</u>		<u>Existing +Project</u>			<u>Significant Impact</u>
			<u>ICU/Delay</u>	<u>LOS</u>	<u>ICU/Delay</u>	<u>LOS</u>	<u>Impact</u>	
1	Las Virgenes Rd & Mureau Rd	AM	0.506	A	0.509	A	+0.003	NO
		PM	0.641	B	0.646	B	+0.005	NO
2	Las Virgenes Rd & NB (WB) 101 Freeway Ramps	AM	24.0	C	24.8	C	+0.8	NO
		PM	18.7	B	18.8	B	+0.1	NO
3	Las Virgenes Rd & SB (EB) 101 Fwy Ramps/Rondell	AM	11.5	B	11.6	C	+0.1	NO
		PM	21.1	C	22.4	C	+1.3	NO
4	Las Virgenes Rd & Agoura Rd	AM	0.610	B	0.613	B	+0.003	NO
		PM	0.599	A	0.603	B	+0.004	NO
5	Lost Hills Road & Agoura Rd	AM	0.501	A	0.504	A	+0.003	NO
		PM	0.601	B	0.602	B	+0.001	NO

Intersectons 1, 4 and 5 are analyzed using ICU volume/capacity

Intersections 2 & 4 are analyzed using HCM Delay seconds per vehicle



Analysis of Future Traffic Conditions

Future traffic volume projections have been developed to analyze the traffic conditions after completion of other planned land developments including the proposed project. Pursuant to the City of Calabasas requirements, the following steps have been taken to develop the future traffic volume estimate:

- (a) Existing traffic + ambient growth to reflect 2016 conditions (1% per year added);
- (b) Traffic in (a) + other planned or anticipated projects in the area for cumulative growth conditions;
- (c) Traffic in (b) + proposed Project traffic (future with cumulative + project conditions);
- (d) Traffic in (b and/or c) + the proposed traffic mitigation, if necessary.

Ambient growth represents projects being developed outside of the analysis area or project not currently identified which may add traffic to the area intersections. The ambient growth rate used for the project was based on Southern California Association of Governments (SCAG) Profile of the City of Calabasas dated May 2013. Growth between years 2000 and 2012 was 10.9% which equates to an average of 0.91% per year ($10.9\%/12\text{years} = 0.91\%/year$). This was rounded to 1% per year.

The future cumulative analysis includes other development projects located within the study area that are either under construction or planned. As part of this analysis, the related project information was obtained from the City of Calabasas and Los Angeles County. It should be noted that this project, or any actions taken by the City regarding this project, does not have a direct bearing on these other proposed cumulative projects. The locations of the cumulative projects are shown in Figure 9 and described in Table 8. The number of trips added to the area by the cumulative projects alone is displayed in Figure 10.

To evaluate future traffic conditions with the cumulative project, estimates of the peak hour trips generated were developed. The potential net increase in traffic from the cumulative projects is shown in Appendix E.



The traffic impact of traffic volume increases has been calculated by adding the existing traffic volume, the ambient growth factor and traffic from the other development project. Future cumulative “without project” peak hour traffic volume estimates are shown in Figures 11 and 12 for the morning and evening peak hours, respectively.

Table 8
Related Projects Descriptions

#	<u>ADDRESS</u>	<u>SIZE</u>	<u>PROJECT & LAND USE</u>	<u>STATUS</u>
1	4240 Las Virgenes Rd	78 units	<u>Paxton Calabasas</u> Townhomes	Application Process
2	4790 Las Virgenes Rd	138 units 8 units 120 room	<u>Canyon Oaks</u> Single Family Homes Affordable Condominiums Hotel	Feasibility Stage
3	NW Corner Las Virgenes & Thousand Oaks Bl	25,820 sf 35,074 sf	<u>Commercial Center</u> Retail Office	Approved by LA Co.
4	26901 Malibu Hills Rd	18,628 sf	<u>Cheesecake Factory</u> Quality Restaurant	Construction
5	26705 Malibu Hills Rd	60 units	<u>Horizons Senior Center</u> Senior Condominiums	Final Construction
6	5300 Lost Hills Rd	600 tons/day 1,500 tons/day	Calabasas Landfill Expansion Current Solid Waste Previous Solid Waste Expand for Contract from both inside & outside Watershed Net Increase from 2007 baseline Estimate conservative 20% during peaks with 50-50 split	LA Co MND



not to scale

FIGURE 9

9/2014

RELATED PROJECT LOCATIONS



Overland Traffic Consultants, Inc.

952 Manhattan Beach Bl #100, Manhattan Beach, Ca 90266
(310) 545-1235 phone, liz@overlandtraffic.com

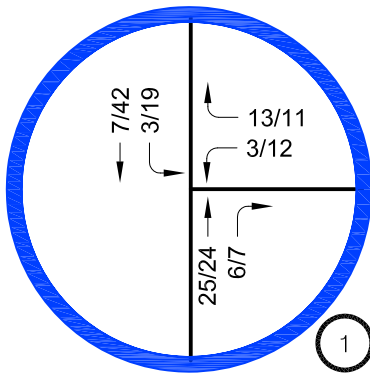

Las Virgenes Rd & Mureau Rd

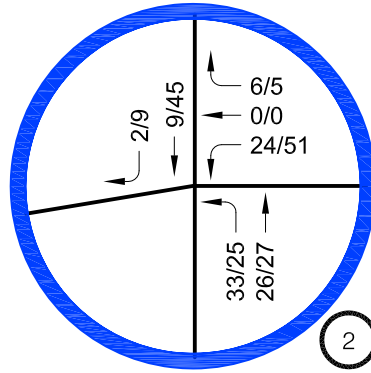

Las Virgenes Rd & NB (WB) 101 Freeway Ramps

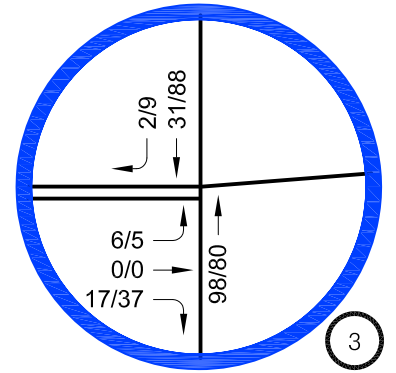

Las Virgenes Rd & SB (EB) 101 Freeway Ramps/Rondell St

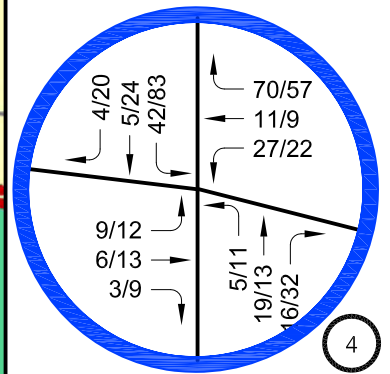

Las Virgenes Rd & Agoura Rd

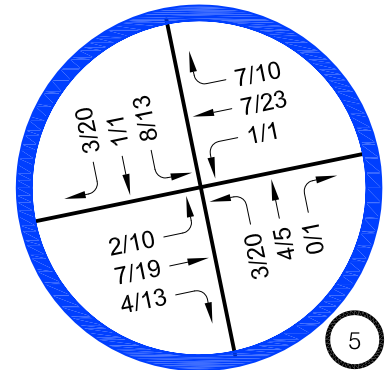

Lost Hills Rd & Agoura Rd

FIGURE 10

12/2014

**RELATED PROJECT ONLY TRAFFIC VOLUMES
AM PEAK HOUR/PM PEAK HOUR**

Overland Traffic Consultants, Inc.

952 Manhattan Beach Bl #100, Manhattan Beach Ca 90266
(310)766-5222, (661)799-8423, liz@overlandtraffic.com

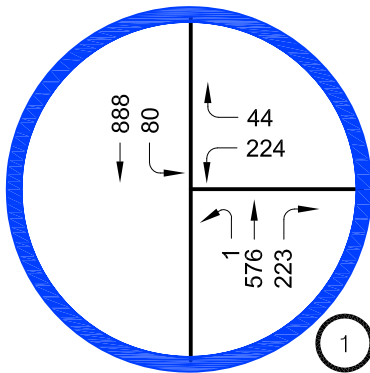

Las Virgenes Rd & Mureau Rd

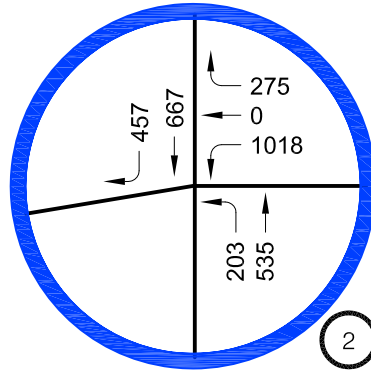

Las Virgenes Rd & NB (WB) 101 Freeway Ramps

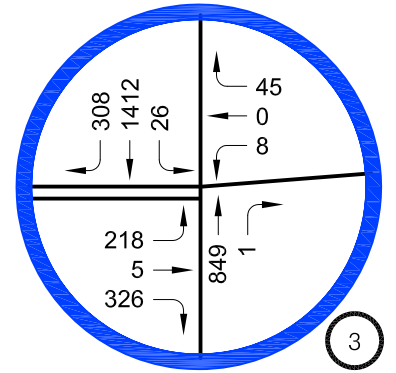

Las Virgenes Rd & SB (EB) 101 Freeway Ramps/Rondell St

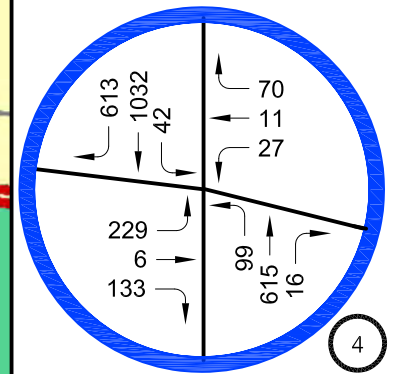

Las Virgenes Rd & Agoura Rd

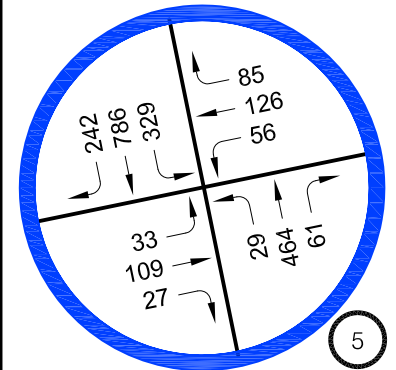

Lost Hills Rd & Agoura Rd

FIGURE 11

**FUTURE (2016) TRAFFIC VOLUMES
WITHOUT PROJECT
AM PEAK HOUR**

Overland Traffic Consultants, Inc.

952 Manhattan Beach Bl #100, Manhattan Beach Ca 90266
(310)766-5222, (661)799-8423, liz@overlandtraffic.com

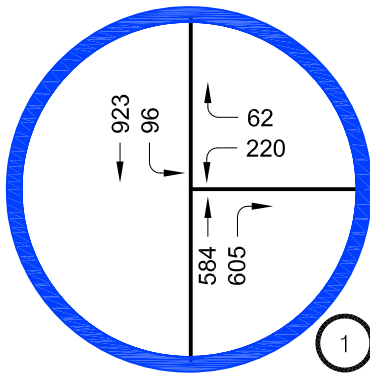

Las Virgenes Rd & Mureau Rd

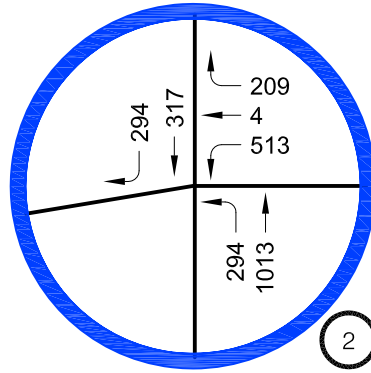

Las Virgenes Rd & NB (WB) 101 Freeway Ramps

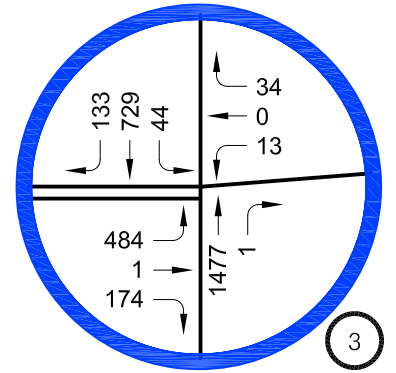

Las Virgenes Rd & SB (EB) 101 Freeway Ramps/Rondell St

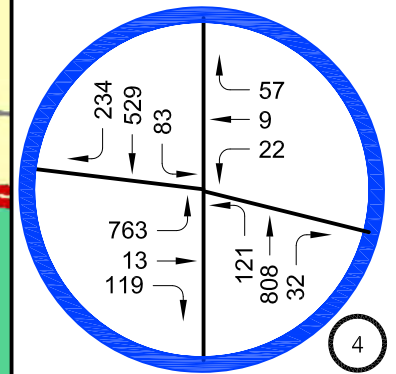

Las Virgenes Rd & Agoura Rd

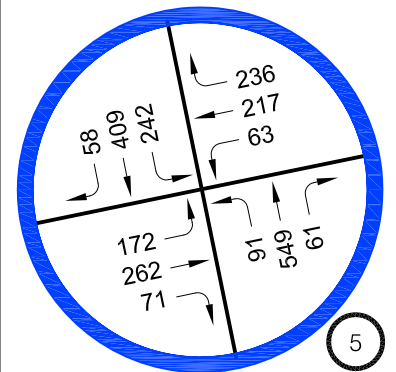

Lost Hills Rd & Agoura Rd

FIGURE 12

12/2014

**FUTURE (2016) TRAFFIC VOLUMES
WITHOUT PROJECT
PM PEAK HOUR**

Overland Traffic Consultants, Inc.

952 Manhattan Beach Bl #100, Manhattan Beach Ca 90266
(310)766-5222, (661)799-8423, liz@overlandtraffic.com

The future cumulative analysis was conducted without the project. These future ICU and HCM and LOS results were compared to the existing traffic conditions. It was determined that none of the intersections will exceed the City LOS requirements. Note that this future analysis includes worst case assumptions of traffic generation, all projects being constructed and does not incorporate intersection improvements proposed and required by some of the other projects. Table 9 displays the results of the future cumulative conditions without the project.

Table 9
Summary of Future Cumulative Traffic Conditions
Without the Project

No.	Intersection	Peak Hour	Existing		Future (2016) Without Project		Growth
			ICU/Delay	LOS	ICU/Delay	LOS	
1	Las Virgenes Rd & Mureau Rd	AM	0.506	A	0.518	A	+ 0.012
		PM	0.641	B	0.676	B	+ 0.035
2	Las Virgenes Rd & NB (WB) 101 Freeway Ramps	AM	24.0	C	28.5	C	+ 4.5
		PM	18.7	B	19.4	B	+ 0.7
3	Las Virgenes Rd & SB (EB) 101 Fwy Ramps/Rondell	AM	11.5	B	12.8	B	+ 1.3
		PM	21.1	C	24.2	C	+ 3.1
4	Las Virgenes Rd & Agoura Rd	AM	0.610	B	0.693	B	+ 0.083
		PM	0.599	A	0.734	C	+ 0.135
5	Los Hills Road & Agoura Rd	AM	0.501	A	0.517	A	+ 0.016
		PM	0.601	B	0.631	B	+ 0.030

Intersections 1, 4 and 5 are analyzed using ICU volume/capacity

Intersections 2 & 4 are analyzed using HCM Delay seconds per vehicle

Traffic conditions after completion of the project have been determined by adding the project volume to the without traffic volume. The traffic impact of the added project traffic at the study intersections is shown in the Table 10 with the comparison of the without and with project traffic conditions at the study intersections. As shown in Table 10, no project related significant traffic impacts occur at the study intersections. It should be noted that the impact analysis does not consider any changes to the existing intersection configuration (i.e., future roadway improvements), including improvements to freeway ramps at Los Hills Road. Future cumulative “with project” peak hour traffic volumes are shown in Figures 13 and 14 for the morning and afternoon, respectively.

Table 10
Summary of Future Cumulative Traffic Conditions
With the Project

<u>No.</u>	<u>Intersection</u>	<u>Peak Hour</u>	<u>Future (2016) Without Project</u>		<u>Future (2016) With Project</u>			<u>Significant Impact</u>
			<u>ICU/Delay</u>	<u>LOS</u>	<u>ICU/Delay</u>	<u>LOS</u>	<u>IMPACT</u>	
1	Las Virgenes Rd & Mureau Rd	AM	0.518	A	0.521	A	+ 0.003	NO
		PM	0.676	B	0.681	B	+ 0.005	NO
2	Las Virgenes Rd & NB (WB) 101 Freeway Ramps	AM	28.5	C	29.7	C	+ 1.2	NO
		PM	19.4	B	19.7	B	+ 0.3	NO
3	Las Virgenes Rd & SB (EB) 101 Fwy Ramps/Rondell	AM	12.8	B	13.2	B	+ 0.4	NO
		PM	24.2	C	26.1	C	+ 1.9	NO
4	Las Virgenes Rd & Agoura Rd	AM	0.693	B	0.698	B	+ 0.005	NO
		PM	0.734	C	0.738	B	+ 0.004	NO
5	Los Hills Road & Agoura Rd	AM	0.517	A	0.518	A	+ 0.001	NO
		PM	0.631	B	0.631	B	+ 0.000	NO

Intersectons 1, 4 and 5 are analyzed using ICU volume/capacity
Intersections 2 & 4 are analyzed using HCM Delay seconds per vehicle

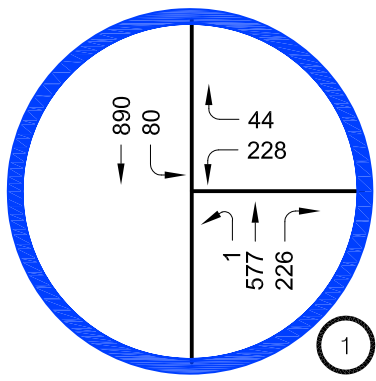

Las Virgenes Rd & Mureau Rd

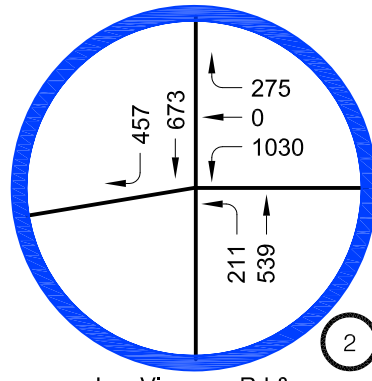

Las Virgenes Rd & NB (WB) 101 Freeway Ramps

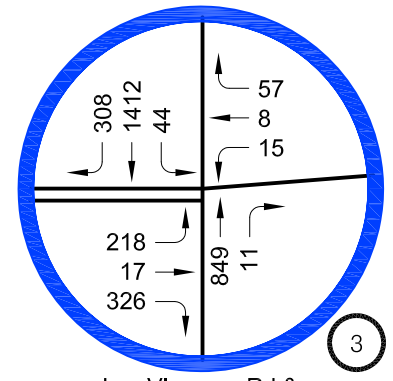

Las Virgenes Rd & SB (EB) 101 Freeway Ramps/Rondell St

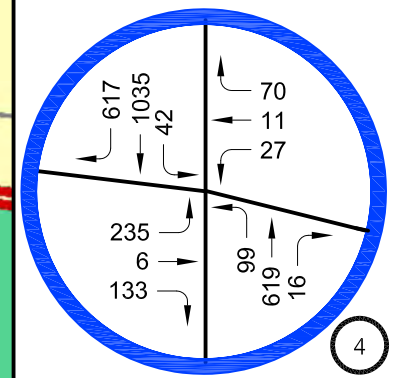

Las Virgenes Rd & Agoura Rd

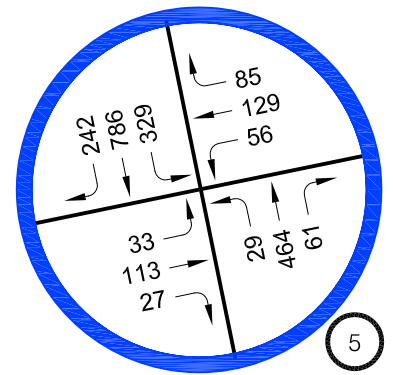

Lost Hills Rd & Agoura Rd

FIGURE 13

**FUTURE (2016) TRAFFIC VOLUMES
WITH PROJECT
AM PEAK HOUR**

Overland Traffic Consultants, Inc.
952 Manhattan Beach Bl #100, Manhattan Beach Ca 90266
(310)766-5222, (661)799-8423, liz@overlandtraffic.com

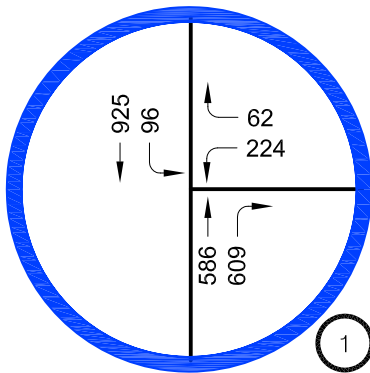

Las Virgenes Rd & Mureau Rd

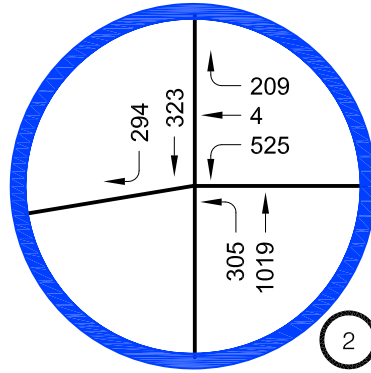

Las Virgenes Rd & NB (WB) 101 Freeway Ramps

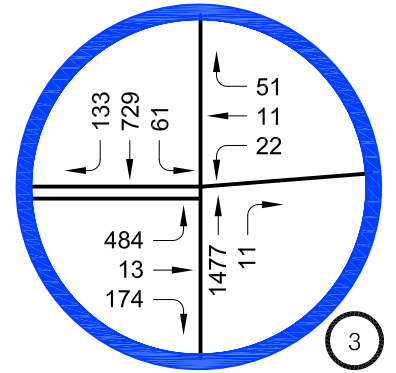

Las Virgenes Rd & SB (EB) 101 Freeway Ramps/Rondell St

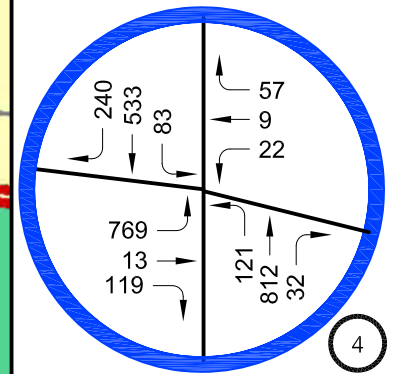

Las Virgenes Rd & Agoura Rd

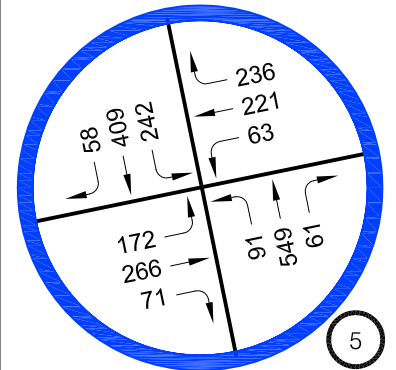

Lost Hills Rd & Agoura Rd

FIGURE 14

12/2014

**FUTURE (2016) TRAFFIC VOLUMES
WITH PROJECT
PM PEAK HOUR**

Overland Traffic Consultants, Inc.
952 Manhattan Beach Bl #100, Manhattan Beach Ca 90266
(310)766-5222, (661)799-8423, liz@overlandtraffic.com



Bicycle Plan Improvements

The City of Calabasas developed a Bicycle Master Plan in October 2013 to encourage alternative modes of transportation throughout the. The Master Plan was developed to address local and regional desires to enhance the viability of cycling as a mode of transportation and reduce traffic in local communities. The Master Plan Mission Statement is as follows:

To develop a cycling network that affords the citizens of Calabasas and outlying communities a safe and comfortable environment for commuters, children, and cycling enthusiasts. To provide an emphasis on “safety first” through the education of both cyclists and non-cyclists.

The plan has mapped out the existing, funded and potential future Bicycle Paths, Bicycle Lanes, and Bicycle Routes. Copies of the Bicycle Plan maps are provided in Appendix F. A brief definition of the facilities is provided below:

Shared Use Path – A facility that provides right-of-way separated from the vehicular traffic for the exclusive use of the cyclist and pedestrians. The designated path can be completely separated from vehicular traffic or cross the vehicular traffic with right-of-way assigned through signals or stop signs.

Bicycle Lane – A bicycle lane is restricted right-of-way that is typically provided on street with a designated lane striped on the street for the exclusive use of the cyclist. The bicycle lanes are occasionally curbside, outside the parking lane, or along a right turn lane at intersections.

Bicycle Route – A bicycle route is a designated route in a cycling system where the cyclist shares the lane with the vehicle. Cyclist would follow the route and share the right-of-way with the vehicle.

Existing bicycle lanes are provided on Las Virgenes Road between Parkmor Road and Agoura Road and on Agoura Road between the City Limits and Las Virgenes Road. A



future bike lane is proposed on Lost Hills Road between the Ventura Freeway and Las Virgenes Road.

Municipal code 17.28.040 requires new projects to provide bicycle parking spaces. Hotel projects are required to provide bicycle parking in the amount of 5% of the number of required vehicle parking spaces. As required and demonstrated below in Table 11, the new Project will provide, at a minimum, 7 bicycle parking spaces.

Table 11
Calabasas Municipal Code 17.28.040
Required Bicycle Parking

Land Use	Size	Bicycle Parking Requirement	Number of Required Spaces
Hotel	127 rooms	5% of Required Vehicle Parking Spaces (0.05 X 140) = 7	7
TOTAL			7

Transit Analysis

The proposed office addition project, is forecast to generate approximately 1,038 weekday daily trips with 67 trips during the AM Peak Hour and 76 trips during the PM Peak Hour. As per Congestion Management Program (CMP) 2004 guidelines person trips can be estimated by multiplying the total trips generated by 1.4. The trips assigned to transit may be calculated by multiplying the person trips generated by 3.5%. The CMP Transit trip generation calculation is displayed below in Table 12.

Table 12
Transit Trips

	<u>DAILY</u>	<u>AM PEAK HOUR</u>	<u>PM PEAK HOUR</u>
PROJECT TRIPS (from Table 2)	1,038	67	76
PERSON TRIPS (trips x 1.4)	1,453	94	106
TRANSIT TRIPS (person trips x 3.5%)	51	3	4

The analysis above indicates a small increase in ridership due to the hotel project and is not expected to adversely affect the current ridership of the transit services in the area.



Impacts on Regional Transportation System

The Congestion Management program (CMP) was adopted to monitor regional traffic growth and related transportation improvements. The CMP designated a transportation network including all state highways and some arterials within the County to be monitored by local jurisdictions. If LOS standards deteriorate on the CMP network, then local jurisdictions must prepare a deficiency plan to be in conformance with the program. Local jurisdictions found to be in nonconformance with the CMP risk the loss of state gas tax funding.

For purposes of the CMP LOS analysis, an increase in the freeway volume by 150 vehicles per hour during the am or pm peak hours in any direction requires further analysis. A substantial change in freeway segments is defined as an increase or decrease of 2% in the demand to capacity ratio when at LOS F. For purposes of CMP intersections, an increase of 50 vehicles or more during the am or pm peak requires further analysis. The intersection of PCH & Malibu Canyon is the nearest CMP intersection. This intersection is approximately 10 miles from the project site. It is anticipated that less than 8 vehicle trips will be passing through the intersection during peak hours and does not exceed the CMP intersection threshold.

The proposed project may add approximately 12 single direction freeway trips in the project area State Route 101 during the peak hours. This is below the CMP significance thresholds of 150 vehicles per hour for potential significant freeway impact. As demonstrated in Table 13, no significant freeway traffic impact is anticipated.

CMP impacts would be less than significant.

Table 13
Freeway CMP Analysis

<u>Location</u>	<u>Time Period</u>	<u>Freeway Capacity</u>	<u>Existing 2014</u>			<u>Future (2016) Without Project</u>			<u>Added Project Traffic</u>	<u>Future (2016) With Project</u>			<u>Impact</u>	<u>Significant?</u>
			<u>Volume</u>	<u>D/C</u>	<u>LOS</u>	<u>Volume</u>	<u>D/C</u>	<u>LOS</u>		<u>Volume</u>	<u>D/C</u>	<u>LOS</u>		
Ventura Freeway	Daily		192,500			196,389			156	196,545				
	Peak Hour	20,000	14,700	0.735	D	14,997	0.750	C	12	15,009	0.750	C	0.0%	No
Ventura Freeway	Daily													
	Peak Hour	20,000												

D/C = demand over capacity

<u>LOS</u>	<u>D/C RATIO</u>	<u>LOS</u>	<u>D/C RATIO</u>
A	0.00 - 0.35	F(0)	>1.00 - 1.25
B	>0.35 - 0.54	F(1)	>1.25 - 1.35
C	>0.64 - 0.77	F(2)	>1.35 - 1.45
D	>0.77 - 0.93	F(3)	>1.45
E	>0.93 - 1.00		



CHAPTER 6

MITIGATION MEASURES

This study has determined that the added traffic volume generated by the proposed new 127 room hotel project will not create any significant project related impacts to the study intersections, bicycle plans, transit services, CMP or access.

The project is providing 11 vehicle parking spaces over code required parking. No parking impacts are anticipated with the project.

The project will construct an extension of Rondell Street as required by the Public Works Department of the City of Calabasas.

APPENDIX A

COMMUNITY PLAN LAND USE INFORMATION

APPENDIX B

**STREET DESIGNATIONS
AND
AERIAL PHOTOS**

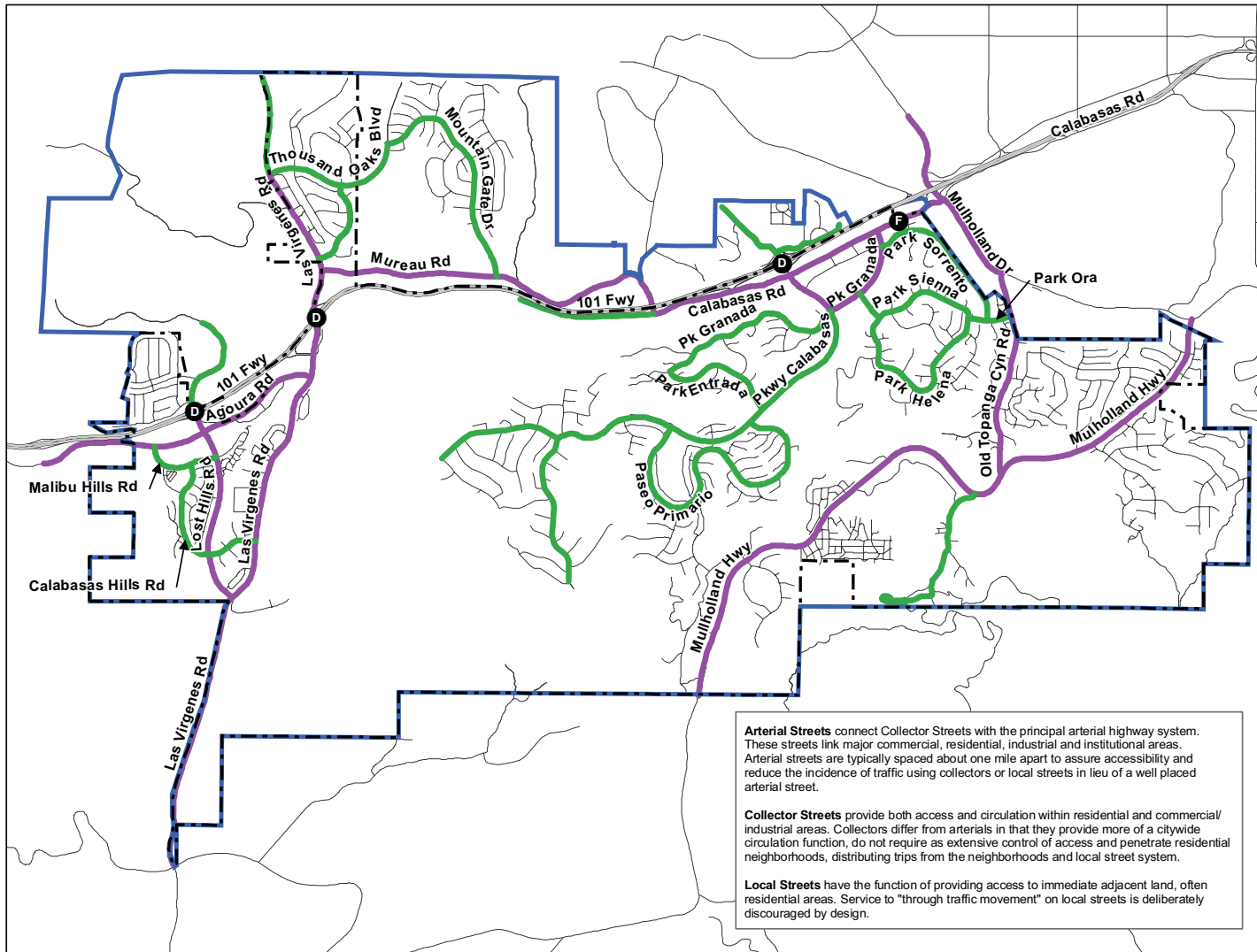

LEGEND

- Calabasas City Boundary
- Plan Area Boundary
- Arterial
- Collector
- Local Street
- Level of Service Standard

Except where indicated, the level of service standard for all roads and intersections in the City is C. The LOS F on Calabasas Road applies to the Old Town Segment.

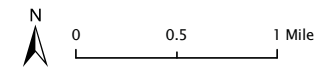

Figure VI-1
Calabasas Roadway System

Source: City of Calabasas, 2007, and Rincon Consultants, 2008.



LAS VIRGENES ROAD & MUREAU ROAD



LAS VIRGENES ROAD & NORTHBOUND 101 FREEWAY RAMPS



LAS VIRGENES ROAD & SOUTHBOUND 101 FREEWAY RAMPS/RONDELL STREET



LAS VIRGENES ROAD & AGOURA HILLS ROAD



AGOURA ROAD AND LOST HILLS ROAD



APPENDIX C

TRANSIT ROUTES

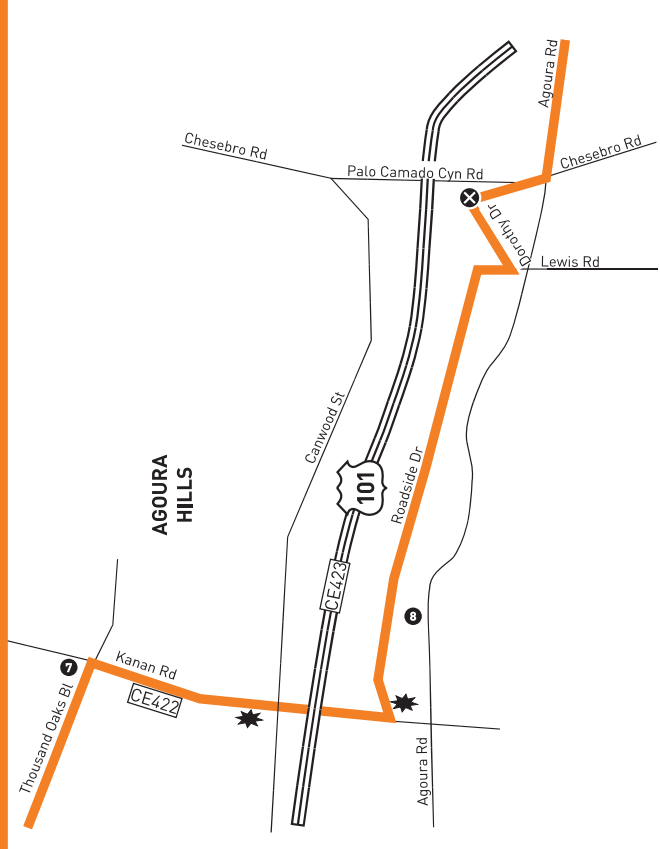
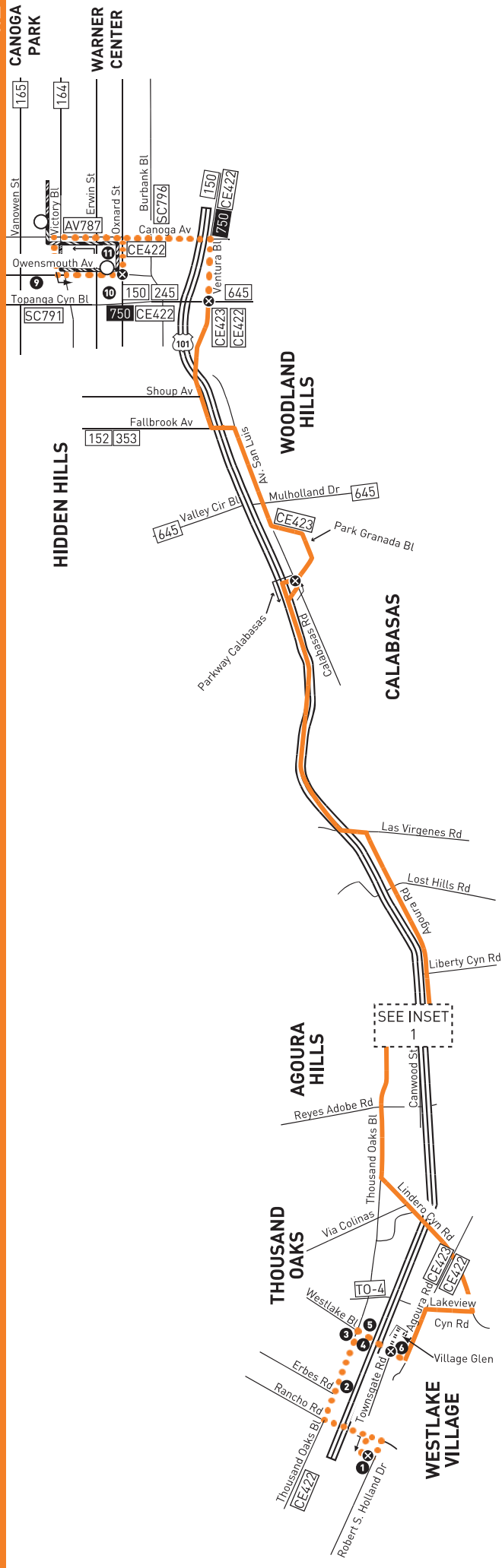

- Route of Line 161
- Shortline, Sunday and Holiday Turnaround loop
- Route of Line 161 Monday thru Saturday
- Route of Orange Line
- Timepoint
- Metro Orange Line Station
- AV** Antelope Valley Transit Authority
- CE** LADOT Commuter Express
- SC** Santa Clarita Transit
- TO** Thousand Oaks Transit
- VISTA** Ventura Intercity Service Transit Authority

- Park/Ride Lots

- 1** Thousand Oaks Transit Center
TO-1, 2, 3, 4; VISTA Conejo Connection; CE422, CE423
- 2** Thousand Oaks Civic Arts Plaza
- 3** North Ranch Mall
- 4** Northgate Shopping Center
- 5** The Promenade at Westlake
- 6** Hyatt Westlake Plaza
- 7** Twin Oaks Shopping Center
- 8** Whizins Center
- 9** Westfield Topanga
- 10** Westfield Promenade
- 11** Warner Center Transit Hub
Metro 161, 164, 245, 645, 750, Orange Line, VISTA Conejo Connection, Nearby transfer to Metro 150, CE422

TO DOWNTOWN LOS ANGELES/USC

TOCTC Park & Ride Bay 1	Agoura & Lindero Canyon	Kanan & Roadside	Las Virgenes & Ventura Fwy Ramps	Pkwy Calabasas & Calabasas	Ventura Blvd & Fallbrook	Topanga Canyon & Ventura Blvd	LADOT Encino Park & Ride	Temple & Broadway	Flower & Olympic	Jefferson & Hoover
A	B	C	D	E	F	G	H	I	J	L
5:15	5:25	5:32	5:41	5:46	5:55	6:00	—	6:25	6:36	6:44
—	—	—	—	—	—	—	6:05	6:29	6:39	6:47
5:27	5:37	5:44	5:52	5:57	6:05	6:11	6:25	6:55	7:05	7:14
5:40	5:52	5:59	6:07	—	—	—	—	6:57	7:07	7:16
—	—	—	—	6:14	6:22	6:28	6:42	7:13	7:23	7:32
6:00	6:13	6:20	6:30	—	—	—	—	7:22	7:32	7:40
—	—	—	—	6:32	6:40	6:46	7:02	7:43	7:53	8:02
—	—	—	—	6:47	6:54	6:59	7:20	8:06	8:16	8:25
6:40	6:53	7:01	7:09	7:13	7:20	7:25	7:46	8:36	8:45	8:54

For this AM commuter service, no drop-offs except at Parkway Calabasas/Calabasas Rd., Ventura Bl./Topanga Cyn., the Encino Park & Ride and in Downtown LA, Figueroa Corridor and USC. No pick-ups in Downtown LA, Figueroa Corridor and USC. Use DASH or Metro Bus for local trips.

TO LADOT ENCINO PARK & RIDE/CALABASAS/THOUSAND OAKS

Jefferson & Hoover	Figueroa & Olympic	Broadway & Temple	LADOT Encino Park & Ride	Topanga Canyon & Ventura Blvd	Ventura Blvd & Fallbrook	Pkwy Calabasas & Calabasas	Las Virgenes & Ventura Fwy Ramps	Kanan & Roadside	Agoura & Lindero Canyon	TOCTC Park & Ride Bay 1
L	K	I	H	G	F	E	D	C	B	A
3:40	3:48	4:02	4:42	4:57	5:00	5:10	5:17	5:25	5:32	5:47
3:55	4:03	4:17	4:57	5:12	5:16	5:26	—	—	—	—
4:00	4:09	4:23	—	—	—	—	5:24	5:33	5:43	5:58
4:15	4:24	4:38	5:20	5:35	5:39	5:49	—	—	—	—
4:20	4:30	4:46	—	—	—	—	5:51	6:00	6:10	6:25
4:35	4:45	5:01	5:51	6:06	6:10	6:20	—	—	—	—
4:50	5:00	5:16	—	—	—	—	6:26	6:35	6:45	7:00
5:05	5:17	5:35	6:27	6:42	6:46	6:54	—	—	—	—
5:30	5:40	5:56	6:45	6:56	6:59	7:07	7:13	7:20	7:27	7:42
6:35	6:45	6:59	7:38	7:49	7:52	8:00	8:06	8:13	8:20	8:35

PM times are indicated in bold type.

For this PM commuter service, no drop-offs in Downtown LA, Figueroa Corridor or USC. No pick-ups except in Downtown LA, Figueroa Corridor or USC and the Encino Park & Ride, Parkway Calabasas/Calabasas Rd., and Ventura Bl./Topanga Cyn. Use DASH or Metro Bus for local trips.

THOUSAND OAKS/AGOURA HILLS/AGOURA/CALABASAS/WOODLAND HILLS/LADOT ENCINO PARK & RIDE

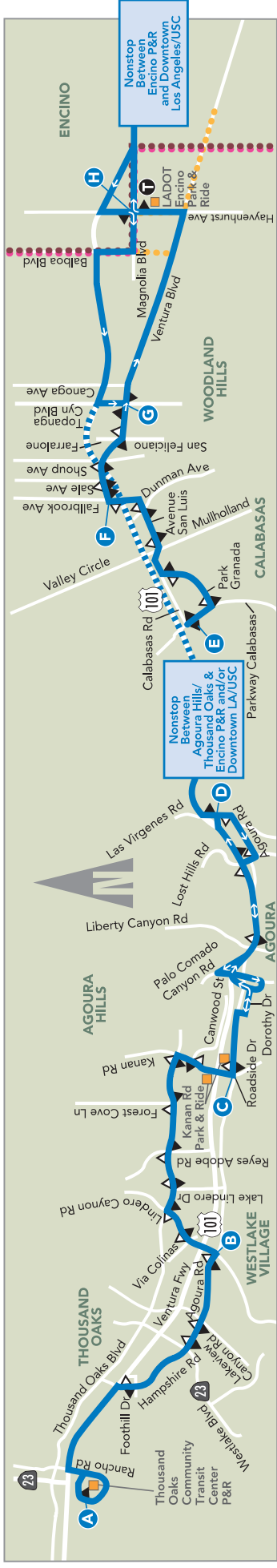

PARK & RIDE LOCATIONS
Thousand Oaks Community Transportation Center (TOCTC) Park & Ride
 265 S. Rancho Road, Thousand Oaks

Caltrans Park & Ride
 (NW) Canwood and Kanan, Agoura Hills
 (SW) Kanan and Roadside, Agoura Hills
 (SE) Kanan and 101 Fwy, Agoura Hills

LADOT Encino Park & Ride
 5174 Hayvenhurst Avenue, Encino

DOWNTOWN LOS ANGELES/USC



	Commuter Express Route 423
	Nonstop Service
	Commuter Express Route 549
	Commuter Express Route 573
	Commuter Express Route 574
	Metro Gold Line
	Metro Red Line
	Metro Purple Line
	Metro Blue Line
	Metro Expo Line
	Metro Silver Line
	Metro Rail Station
	Bus Stop
	Drop-off Only
	Points of Interest
	Park & Ride Lot
	Time Point
	Transfer Point

CALABASAS TROLLEY SCHEDULE

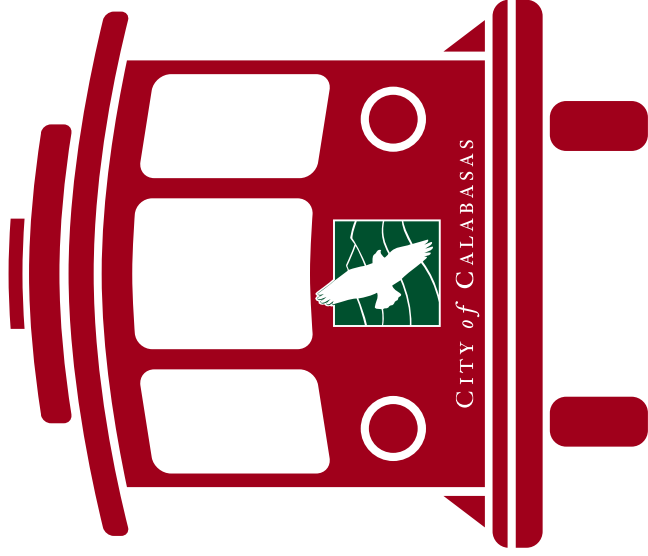

For Friday and Saturday Service

FREE - NO CHARGE



Hours of operation are:

Fridays: 6pm to 10pm

Saturdays: 10am to 10pm

There is no service between 3pm & 4pm

The Trolley requires mid-day refueling. Service will not be available during the 3:00pm hour.

The Calabasas Trolley performs a loop route in one direction throughout the City. A route map is included on the backside of this schedule for your convenience.

There is no charge to ride the Calabasas Trolley. The driver may be requested to stop along the route for unscheduled passenger drop-off. This request shall be where it is safe to do so at the discretion of the driver. For more information, contact Calabasas Transportation Customer Service (805) 557-7372.



CITY of CALABASAS

100 Civic Center Way, Calabasas CA 91302
www.cityofcalabasas.com
 (818) 224-1600

All times noted are minutes after each hour.

TROLLEY STOPS		TIMES
STOP	LOCATION	
1	Las Virgenes Rd. @ Thousand Oaks Blvd. (SW)	0:00
2	Agoura Rd. @ Las Virgenes (Albertson's)	0:03
3	Agoura Rd. @ Lost Hills Rd.	0:04
4	Malibu Hills Rd. @ Agoura Rd. (Community Center)	0:05
5	Lost Hills Rd. @ Las Virgenes Rd. (De Anza Park)	0:08
6	Mureau Rd. @ Las Virgenes Rd. (SE)	0:11
7	Parkway Calabasas @ Calabasas Rd.	0:16
8	Parkway Calabasas @ Park Granada	0:17
9	Parkway Calabasas @ Park Entrada	0:19
10	Parkway Calabasas @ Camino Portal	0:20
11	Parkway Calabasas @ Paseo Primario (North)	0:21
12	Park Sorrento @ Civic Center Way (City Hall/Library)	0:25
13	Park Granada @ Park Capri	0:28
14	Park Granada @ Calabasas Rd. (Downtown)	0:30
15	Calabasas Rd. @ El Canon Ave. (Oldtown)	0:31
16	Mulholland Hwy. @ Freedom Dr.	0:36
17	Mulholland Hwy. @ Eddingham	0:38
18	Mulholland Hwy. @ Mobil Home Park	0:42
19	Old Topanga Cyn. @ Calabasas High School	0:45
20	Old Topanga Cyn. @ Wrencrest Dr.	0:46
21	Park Sorrento @ Park Ora	0:48
22	Park Sorrento @ Park Mirasol (Tennis & Swim Ctr.)	0:49
23	Calabasas Rd. @ Commons Way (Babies "R" Us)	0:50
24	Park Sorrento @ Civic Center Way (City Hall/Library)	0:52
25	Mureau Rd. @ Las Virgenes Rd. (NE)	0:59

CALABASAS TROLLEY

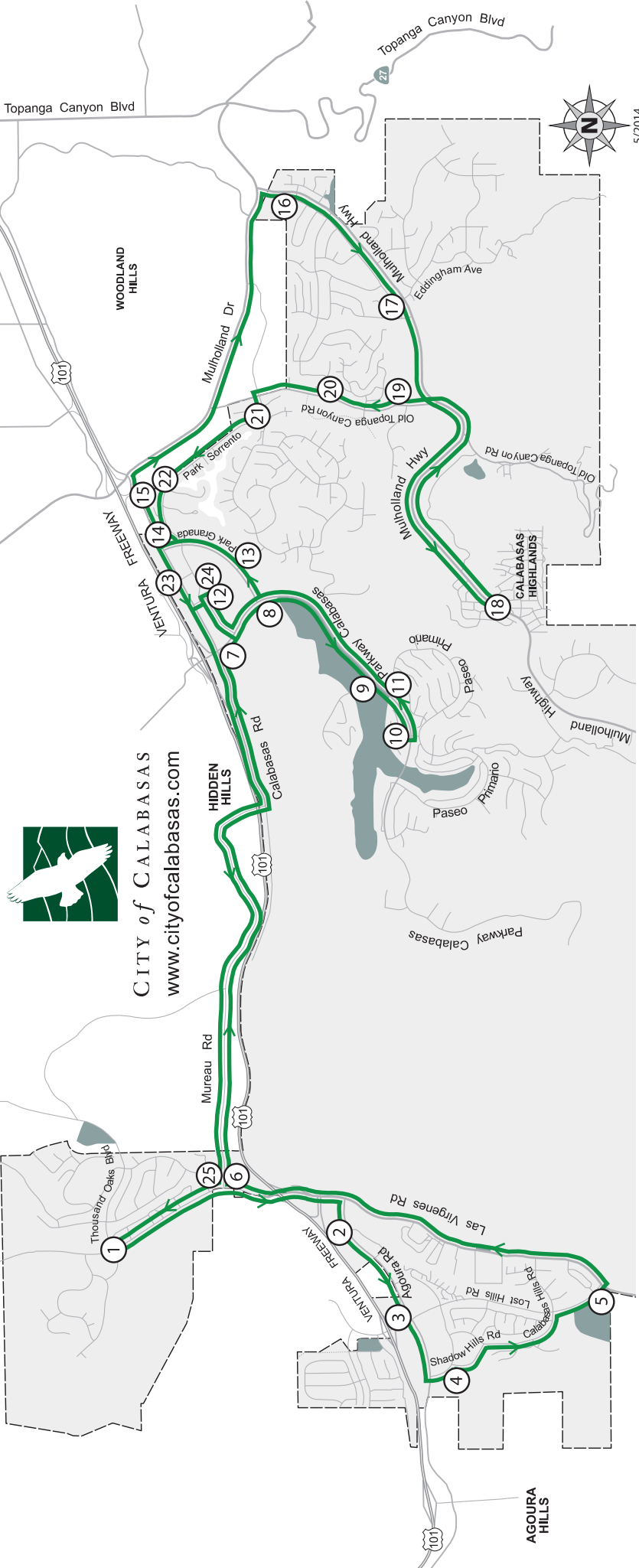

CITY of CALABASAS
www.cityofcalabasas.com



STOP	LOCATION	TIMES
1	Las Virgenes Rd. @ Thousand Oaks Blvd. (SW)	0:00
2	Agoura Rd. @ Las Virgenes (Albertson's)	0:03
3	Agoura Rd. @ Lost Hills Rd.	0:04
4	Malibu Hills Rd. @ Agoura Rd. (Community Center)	0:05
5	Lost Hills Rd. @ Las Virgenes Rd. (De Anza Park)	0:08
6	Murreau Rd. @ Las Virgenes Rd. (SE)	0:11
7	Parkway Calabasas @ Calabasas Rd.	0:16
8	Parkway Calabasas @ Park Granada	0:17
9	Parkway Calabasas @ Park Entrada	0:19
10	Parkway Calabasas @ Camino Portal	0:20
11	Parkway Calabasas @ Paseo Primario (North)	0:21
12	Park Sorrento @ Civic Center Way (City Hall/Library)	0:25
13	Park Granada @ Park Capri	0:28

Hours of Operation: Friday 6pm to 10pm
 Saturday 10am to 10pm
 Please Note: There is no service between 3pm & 4pm

STOP	LOCATION	TIMES
14	Park Granada @ Calabasas Rd. (Downtown)	0:30
15	Calabasas Rd. @ El Canon Ave. (Oldtown)	0:31
16	Mulholland Highway @ Freedom Dr.	0:36
17	Mulholland Hwy. @ Eddingham	0:38
18	Mulholland Hwy. @ Mobil Home Park	0:42
19	Old Topanga Cyn. @ Calabasas High School	0:45
20	Old Topanga Cyn. @ Wrencrest Dr.	0:46
21	Park Sorrento @ Park Ora	0:48
22	Park Sorrento @ Park Mirasol (Tennis & Swim Ctr.)	0:49
23	Calabasas Rd. @ Commons Way (Babies "R" Us)	0:50
24	Park Sorrento @ Civic Center Way (City Hall/Library)	0:52
25	Murreau Rd. @ Las Virgenes Rd. (NE)	0:59

- Subject to change without notice.
 - Public information available at
 Calabasas Transportation Customer Service (805) 557-7372

LINE 1 SHUTTLE

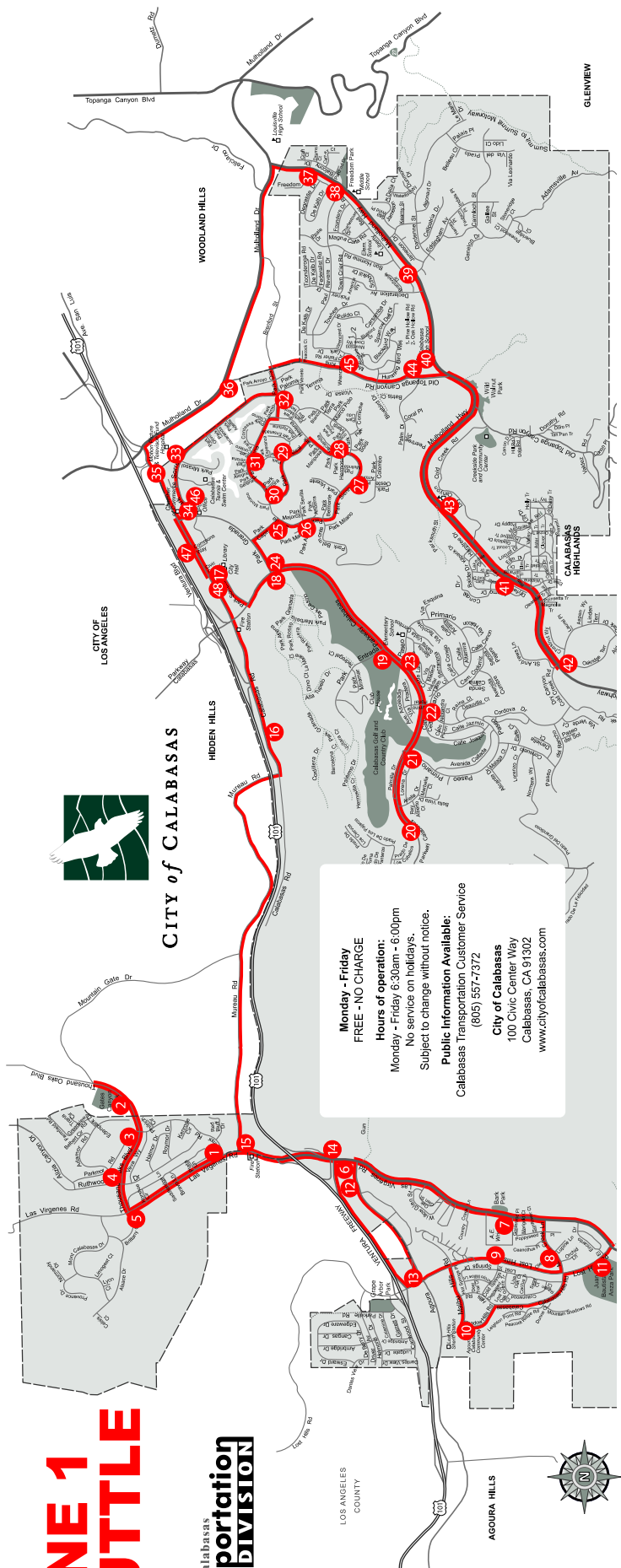

Monday - Friday
FREE - NO CHARGE
Hours of operation:
 Monday - Friday 6:30am - 6:00pm
 No service on holidays.
 Subject to change without notice.

Public Information Available:
 Calabasas Transportation Customer Service
 (805) 557-7372

City of Calabasas
 100 Civic Center Way
 Calabasas, CA 91302
 www.cityofcalabasas.com

STOP	LOCATION	TIMES	TIMES	TIMES	TIMES	TIMES	TIMES
25	Park Sienna at Park Capri	7:26 AM	9:14 AM	11:12 AM	1:00 PM	2:48 PM	4:46 PM
26	Park Sienna at Park Antigua	7:27 AM	9:15 AM	11:13 AM	1:01 PM	2:49 PM	4:47 PM
27	Park Sienna at Park Antonio	7:28 AM	9:16 AM	11:14 AM	1:02 PM	2:50 PM	4:48 PM
28	Park Helena at Park Hacienda	7:29 AM	9:17 AM	11:15 AM	1:03 PM	2:51 PM	4:49 PM
29	Park Alisal at Park Corona	7:30 AM	9:18 AM	11:16 AM	1:04 PM	2:52 PM	4:50 PM
30	Park Sienna at Park Alisal	7:31 AM	9:19 AM	11:17 AM	1:05 PM	2:53 PM	4:51 PM
31	Park Sienna at Park Cordero	7:32 AM	9:20 AM	11:18 AM	1:06 PM	2:54 PM	4:52 PM
32	Park Sorrento at Park Ora	7:33 AM	9:21 AM	11:19 AM	1:07 PM	2:55 PM	4:53 PM
33	Park Sorrento at Park Mirasol	7:35 AM	9:23 AM	11:21 AM	1:09 PM	2:57 PM	4:55 PM
34	Park Sorrento at Park Granada	7:36 AM	9:24 AM	11:22 AM	1:10 PM	2:58 PM	4:56 PM
35	Calabasas Road at El Canon Avenue	7:37 AM	9:25 AM	11:23 AM	1:11 PM	2:59 PM	4:57 PM
36	Mulholland Drive at Valmar Road	7:39 AM	9:27 AM	11:25 AM	1:13 PM	3:01 PM	4:59 PM
37	Mulholland Highway at Paul Revere Drive	7:43 AM	9:31 AM	11:29 AM	1:17 PM	3:05 PM	5:03 PM
38	Mulholland Highway at Freedom Drive	7:44 AM	9:32 AM	11:30 AM	1:18 PM	3:06 PM	5:04 PM
39	Mulholland Highway at Eddingham Avenue	7:46 AM	9:34 AM	11:32 AM	1:20 PM	3:08 PM	5:06 PM
40	Mulholland Highway at Calabasas High School	7:47 AM	9:35 AM	11:33 AM	1:21 PM	3:09 PM	5:07 PM
41	Mulholland Highway at Mobile Home Estates	7:52 AM	9:40 AM	11:38 AM	1:26 PM	3:14 PM	5:12 PM
42	Mulholland Highway at Mountain Park Drive	7:54 AM	9:42 AM	11:40 AM	1:28 PM	3:16 PM	5:14 PM
43	Mulholland Highway at Viewpoint School	7:57 AM	9:45 AM	11:43 AM	1:31 PM	3:19 PM	5:17 PM
44	Old Topanga Canyon Road at Calabasas High School	8:00 AM	9:48 AM	11:46 AM	1:34 PM	3:21 PM	5:19 PM
45	Old Topanga Canyon Road at Wrencrest Drive	8:01 AM	9:49 AM	11:47 AM	1:35 PM	3:23 PM	5:21 PM
46	Park Sorrento at Park Granada	8:04 AM	9:52 AM	11:50 AM	1:38 PM	3:26 PM	5:24 PM
47	Calabasas Road at Commons Way	8:06 AM	9:54 AM	11:52 AM	1:40 PM	3:28 PM	5:26 PM
48	Park Sorrento at Civic Center Way (City Hall)	8:07 AM	9:55 AM	11:53 AM	1:41 PM	3:29 PM	5:27 PM

STOP	LOCATION	TIMES	TIMES	TIMES	TIMES	TIMES	TIMES
1	Las Virgenes Road at Parkmor Road	6:30 AM	8:18 AM	10:06 AM	12:04 PM	1:52 PM	3:40 PM
2	Thousand Oaks Boulevard at Gates Canyon Park	6:34 AM	8:22 AM	10:10 AM	12:08 PM	1:56 PM	3:44 PM
3	Thousand Oaks Boulevard at Parkmor Road	6:35 AM	8:23 AM	10:11 AM	12:09 PM	1:57 PM	3:45 PM
4	Thousand Oaks Boulevard at Ruthwood Drive	6:36 AM	8:24 AM	10:12 AM	12:10 PM	1:58 PM	3:46 PM
5	Las Virgenes Road at Thousand Oaks Boulevard	6:38 AM	8:26 AM	10:14 AM	12:12 PM	2:00 PM	3:48 PM
6	Las Virgenes Road at Shell Station	6:41 AM	8:29 AM	10:17 AM	12:15 PM	2:03 PM	3:51 PM
7	Las Virgenes Road at A.E. Wright Middle School	6:44 AM	8:32 AM	10:30 AM	12:18 PM	2:06 PM	4:04 PM
8	Meadow Creek Lane at Oleander Court	6:46 AM	8:34 AM	10:31 AM	12:19 PM	2:07 PM	4:05 PM
9	Lost Hills Road at Cold Springs Street	6:45 AM	8:33 AM	10:31 AM	12:19 PM	2:07 PM	4:05 PM
10	Malibu Hills Road at Agoura Hills/Calabasas Community Center	6:49 AM	8:37 AM	10:35 AM	12:23 PM	2:11 PM	4:09 PM
11	Agoura Hills Road at Juan Bautista de Anza Park	6:52 AM	8:40 AM	10:38 AM	12:26 PM	2:14 PM	4:12 PM
12	Agoura Hills Road at Las Virgenes Road (Metro)	6:57 AM	8:45 AM	10:43 AM	12:31 PM	2:19 PM	4:17 PM
13	Agoura Road at Lost Hills Road (Metro - Summit)	6:59 AM	8:47 AM	10:45 AM	12:33 PM	2:21 PM	4:19 PM
14	Las Virgenes Road at Southbound US 101	7:01 AM	8:49 AM	10:49 AM	12:37 PM	2:25 PM	4:23 PM
15	Las Virgenes Road at Mureau Road	7:03 AM	8:51 AM	10:49 AM	12:37 PM	2:25 PM	4:23 PM
16	Calabasas Road between BMW/Acura Dealerships	7:10 AM	8:58 AM	10:56 AM	12:44 PM	2:32 PM	4:30 PM
17	Park Sorrento at Civic Center Way (City Hall)	7:12 AM	9:00 AM	10:58 AM	12:46 PM	2:34 PM	4:32 PM
18	Parkway Calabasas at Park Granada	7:13 AM	9:01 AM	10:59 AM	12:47 PM	2:35 PM	4:33 PM
19	Parkway Calabasas at Park Entrada	7:15 AM	9:03 AM	11:01 AM	12:49 PM	2:37 PM	4:35 PM
20	Parkway Calabasas at the Oaks Gate	7:19 AM	9:07 AM	11:05 AM	12:53 PM	2:41 PM	4:39 PM
21	Parkway Calabasas at Paseo Primario (South)	7:20 AM	9:08 AM	11:06 AM	12:54 PM	2:42 PM	4:40 PM
22	Parkway Calabasas at Camino Portal	7:21 AM	9:09 AM	11:07 AM	12:55 PM	2:43 PM	4:41 PM
23	Parkway Calabasas at Paseo Primario (North)	7:22 AM	9:10 AM	11:08 AM	12:56 PM	2:44 PM	4:42 PM
24	Park Granada at Parkway Calabasas	7:25 AM	9:13 AM	11:11 AM	12:59 PM	2:47 PM	4:45 PM

**CALABASAS PUBLIC TRANSPORTATION
SHUTTLE SERVICE**

FALL LINE 2 AM

With Stops at A.E. Wright & Lupin Hill

Hours of operation:

Monday - Friday
Transit Pass or Transit tickets required.
No service on holidays.
Subject to change without notice.

Public Information Available:

Calabasas Transportation
Customer Service
(805) 557-7372
100 Civic Center Way
Calabasas, CA 91302
www.cityofcalabasas.com

Updated: September 2012

LINE 2 PEAK ROUTE AM			
STOP	LOCATION	TIMES	TIMES
1	Las Virgenes Rd. @ A.E. Wright (South Driveway)	7:07	-
2	Meadow Creek Ln. @ Poppyseed Pl.	7:08	-
3	Meadow Creek Ln. @ Oleander	7:09	-
4	Lost Springs Rd. @ Cold Springs St.	7:11	-
5	Lost Hills Rd. @ Malibu Hills Rd.	7:14	-
6	Parkville Rd. @ Calamine Dr.	7:17	-
7	Helmond Dr. @ Ludgate Dr.	7:18	-
8	Canwood St. @ Ambridge Dr.	7:19	-
9	Las Virgenes Rd. @ Parkmor Rd.	7:23	-
10	Las Virgenes Rd. @ Bravo Ln.	7:24	-
11	Las Virgenes Rd. @ Thousand Oaks Blvd. (SE)	7:25	-
12	Parkmor Rd. @ Adamor Rd. (Lupin Hill)	7:30	-
13	Parkmor Rd. @ Alizia Canyon Dr.	7:31	-
14	Las Virgenes Rd. @ Malibu Cyn. Apts. Leasing Ct.	7:34	-
15	Ruthwood Dr. @ Veva Way	7:40	7:48
16	Ruthwood Dr. @ Parkmor Rd.	7:42	7:49
17	Parkmor Rd. @ Roymor Dr.	7:44	7:51
18	Parkmor Rd. @ Adamor Rd. (Lupin Hill)	7:46	-
19	Parkmor Rd. @ Alizia Canyon Dr.	7:47	-
20	Las Virgenes Rd. @ Malibu Cyn. Apts. Leasing Ct.	-	7:55
21	Las Virgenes Rd. @ Thousand Oaks Blvd. (SW)	-	8:01
22	Las Virgenes Road @ Shell Station	-	8:05
23	Las Virgenes Rd. @ Willow Glen St.	-	8:08
24	Las Virgenes Rd. @ A.E. Wright (South Driveway)	-	8:09
			8:45

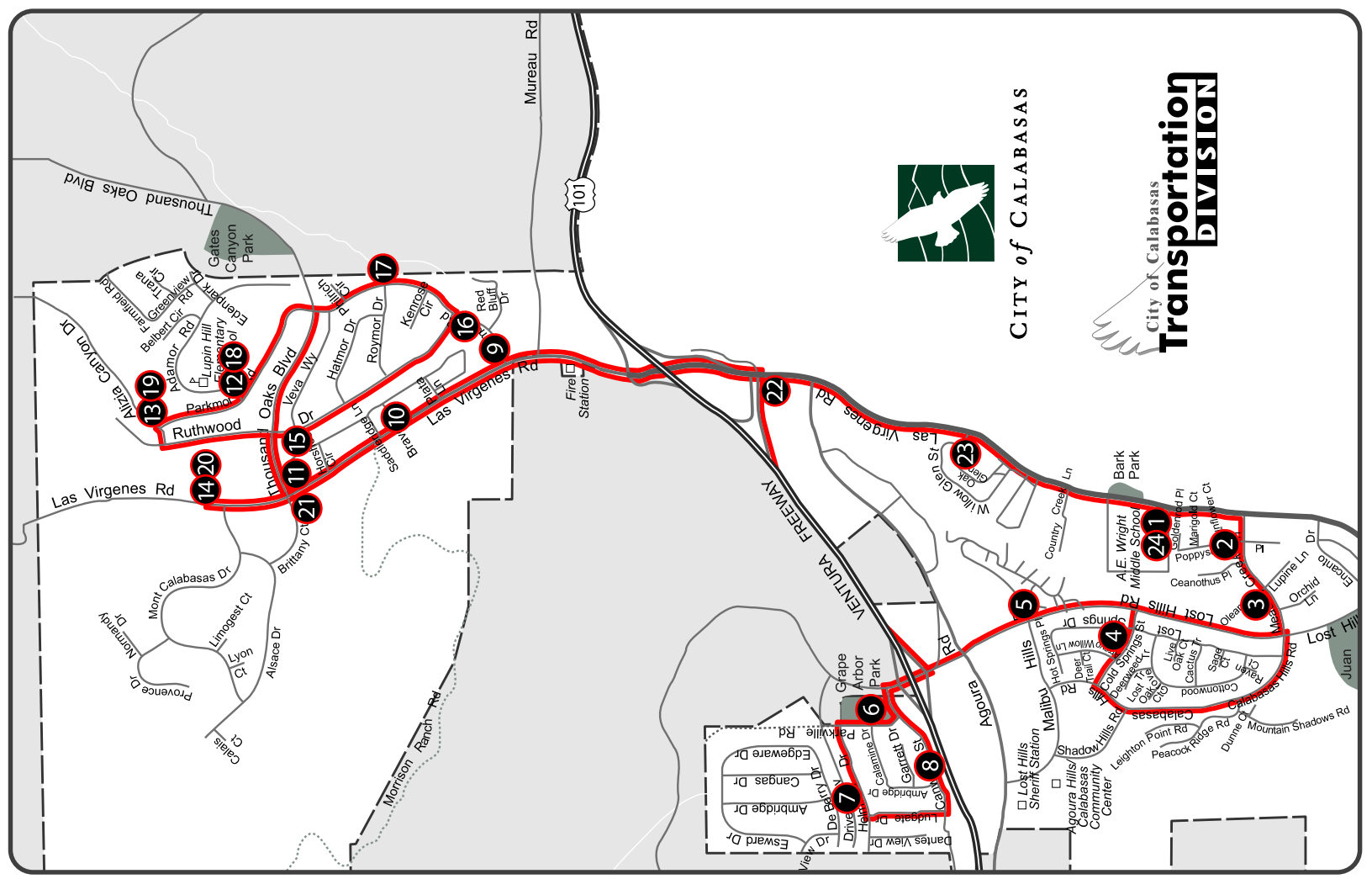

CITY of CALABASAS



City of Calabasas
**Transportation
DIVISION**

CALABASAS PUBLIC TRANSPORTATION SHUTTLE SERVICE

FALL LINE 2PM

With Stops at A.E. Wright & Lupin Hill

Hours of operation:

Monday - Friday
Transit Pass or Transit tickets required.
No service on holidays.
Subject to change without notice.

Public Information Available:

Calabasas Transportation
Customer Service
(805) 557-7372

100 Civic Center Way
Calabasas, CA 91302
www.cityofcalabasas.com

Updated: September 2012

LINE 2 PEAK ROUTE PM							
STOP	LOCATION	TIMES	TIMES	WED	THUR	THUR	
1	Parkmor Rd. @ Adamor Rd. (Lupin Hill)	2:15	2:40	12:30	-	2:15	2:40
2	Ruthwood Dr. @ Veva Way	2:16	2:41	12:31	-	2:16	2:41
3	Ruthwood Dr. @ Parkmor Rd.	2:17	2:42	12:32	-	2:17	2:42
4	Las Virgenes Rd. @ Bravo Ln.	2:19	2:44	12:34	-	2:19	2:44
5	Las Virgenes Rd. @ Malibu Cyn. Apts. Leasing Ct.	2:20	2:44	12:35	-	2:20	2:44
6	Las Virgenes Rd. @ Thousand Oaks Blvd. (SW)	2:22	2:46	12:36	-	2:22	2:46
7	Las Virgenes Rd. @ Willow Glen St.	2:24	2:48	12:39	-	2:24	2:48
8	Meadow Creek Ln. @ Poppyseed Pl.	2:25	2:49	12:40	-	2:25	2:49
9	Meadow Creek Ln. @ Oleander	2:26	2:50	12:41	-	2:26	2:50
10	Lost Springs Rd. @ Cold Springs St.	2:27	2:51	12:43	-	2:27	2:51
11	Lost Hills Rd. @ Malibu Hills Rd.	2:32	2:56	12:48	-	2:32	2:56
12	Parkville Rd. @ Calamine Dr.	2:35	2:59	12:52	-	2:35	2:59
13	Helmond Dr. @ Ludgate Dr.	2:36	3:00	12:53	-	2:36	3:00
14	Canwood St. @ Ambridge Dr.	2:37	3:01	12:54	-	2:37	3:01
15	Las Virgenes Rd. @ Willow Glen St.	-	3:06	12:59	-	-	3:06
16	Las Virgenes Rd. @ A.E. Wright (South Driveway)	-	3:20	3:20	1:15	-	-
17	Meadow Creek Ln. @ Poppyseed Pl.	-	3:21	3:21	1:16	-	-
18	Meadow Creek Ln. @ Oleander	-	3:22	3:22	1:17	-	-
19	Lost Springs Rd. @ Cold Springs St.	-	3:23	3:23	1:18	-	-
20	Lost Hills Rd. @ Malibu Hills Rd.	-	3:26	3:26	1:21	-	-
21	Parkville Rd. @ Calamine Dr.	-	3:29	3:29	1:24	-	-
22	Helmond Dr. @ Ludgate Dr.	-	3:30	3:30	1:25	-	-
23	Canwood St. @ Ambridge Dr.	-	3:31	3:31	1:26	-	-
24	Las Virgenes Rd. @ Bravo Ln.	-	3:36	3:36	1:31	-	-
25	Las Virgenes Rd. @ Thousand Oaks Blvd. (SE)	-	3:37	3:37	1:32	-	-
26	Ruthwood Dr. @ Veva Way	-	3:39	3:39	1:34	-	-
27	Ruthwood Dr. @ Parkmor Rd.	-	3:40	3:40	1:35	-	-
28	Parkmor Rd. @ Adamor Rd.	-	3:42	3:42	1:37	-	-
29	Parkmor Rd. @ Alizia Canyon Dr.	-	3:43	3:43	1:38	-	-
30	Las Virgenes Rd. @ Thousand Oaks Blvd. (SW)	-	3:45	3:45	1:39	-	-
31	Las Virgenes Rd. @ Willow Glen St.	-	3:48	3:48	1:43	-	-

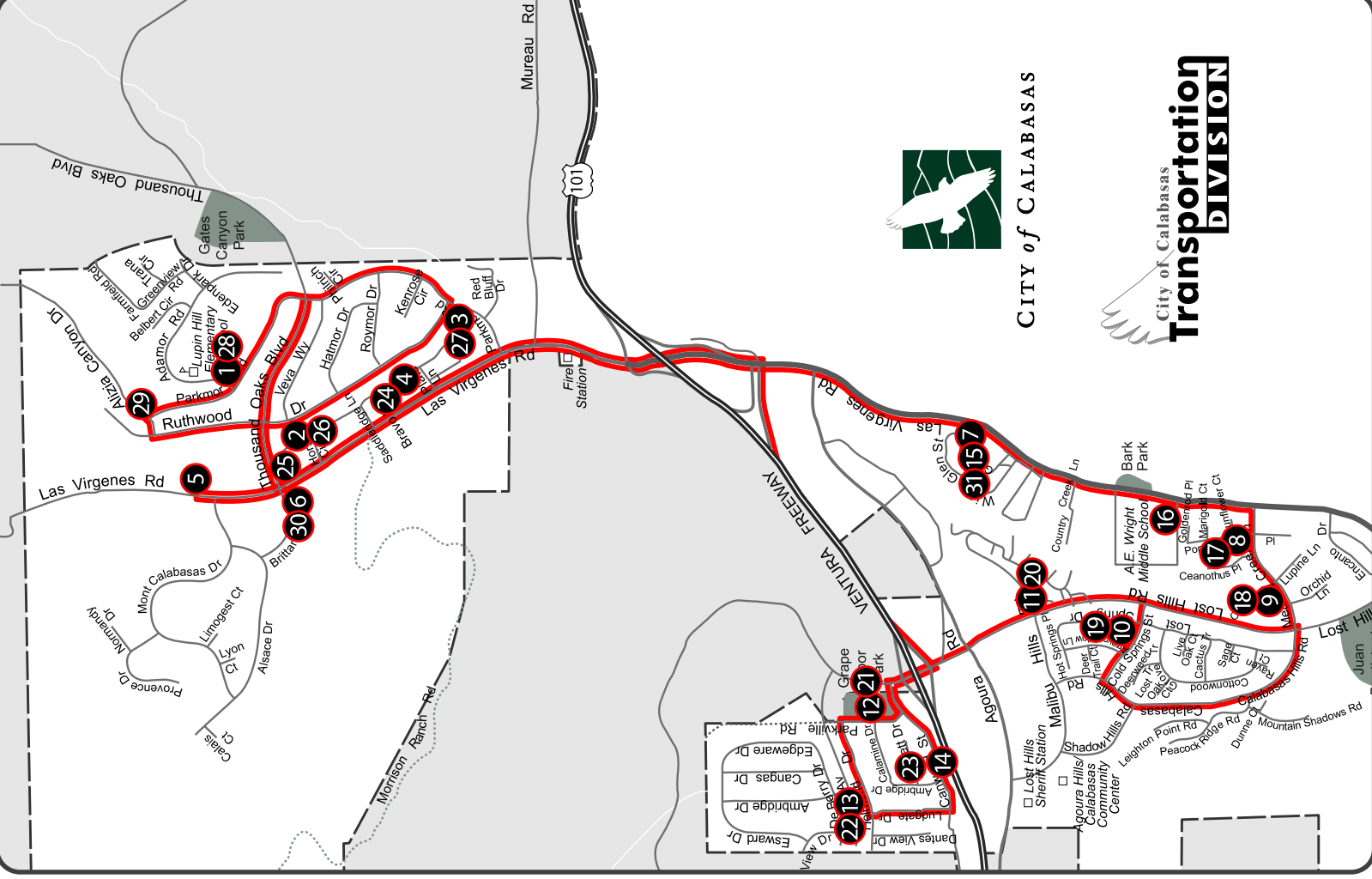

CITY of CALABASAS

City of Calabasas
Transportation
DIVISION

**CALABASAS PUBLIC TRANSPORTATION
SHUTTLE SERVICE**

FALL LINE 5AM

With Stops at C.H.S.

Hours of operation:

Monday - Friday
Transit Pass or Transit tickets required.
No service on holidays.
Subject to change without notice.

Public Information Available:

Calabasas Transportation
Customer Service
(805) 557-7372
100 Civic Center Way
Calabasas, CA 91302
www.cityofcalabasas.com

Updated: September 2012

LINE 5AM PEAK ROUTE		
STOP	LOCATION	TIMES
1	Las Virgenes Rd. @ Willow Glen St.	6:50
2	Meadow Creek Ln. @ Poppyseed Pl.	6:52
3	Meadow Creek Ln. @ Oleander	6:53
4	Lost Hills Rd. @ Cold Springs St.	6:54
5	Calabasas Hills Rd. @ Peacock Ridge Rd.	6:56
6	Lost Hills Rd. @ Malibu Hills Rd.	6:58
7	Parkville Rd. @ Calamine Dr.	7:01
8	Helmond Dr. @ Ludgate Dr.	7:02
9	Canwood St. @ Ambridge Dr.	7:03
10	Las Virgenes Rd. @ Parkmor Rd.	7:10
11	Las Virgenes Rd. @ Bravo Ln.	7:11
12	Ruthwood Dr. @ Veva Way	7:13
13	Ruthwood Dr. @ Parkmor Rd.	7:15
14	Parkmor Rd. @ Roymor Dr.	7:17
15	Parkmor Rd. @ Adamor Rd.	7:19
16	Parkmor Rd. @ Alizia Canyon Dr.	7:21
17	Las Virgenes Rd. @ Thousand Oaks Blvd. (SW)	7:23
18	Old Topanga Canyon Rd. @ C.H.S.	7:38

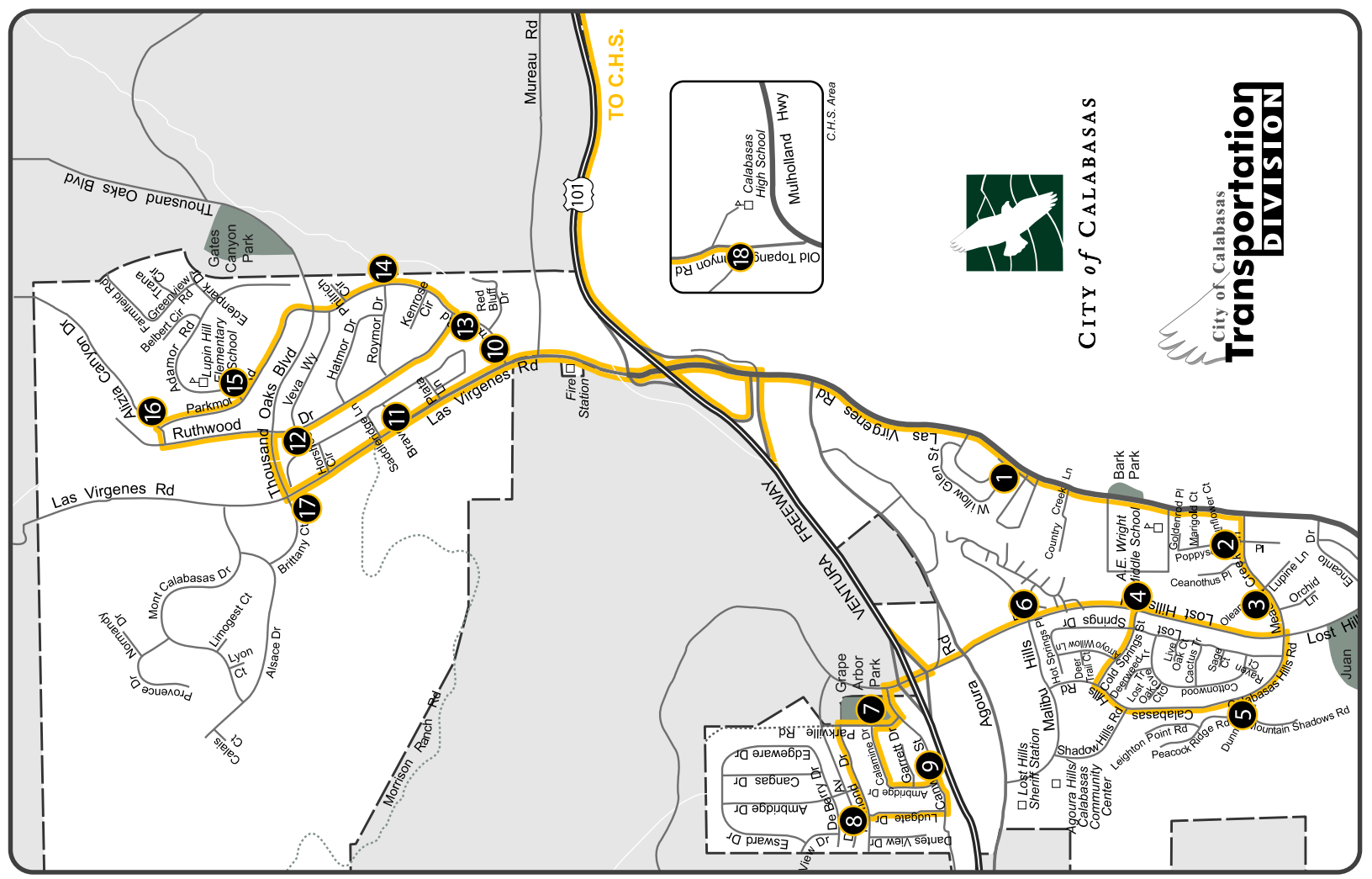

CITY OF CALABASAS

City of Calabasas
Transportation
DIVISION

**CALABASAS PUBLIC TRANSPORTATION
SHUTTLE SERVICE**

FALL LINE 5 PM

With Stops at C.H.S.

Hours of operation:

Monday - Friday
Transit Pass or Transit tickets required.
No service on holidays.
Subject to change without notice.

Public Information Available:

Calabasas Transportation
Customer Service
(805) 557-7372

100 Civic Center Way
Calabasas, CA 91302
www.cityofcalabasas.com

Updated: September 2012

LINE 5 PM PEAK ROUTE		
STOP	LOCATION	TIMES
1	Old Topanga Canyon Rd. @ C.H.S.	3:20
2	Las Virgenes Rd. @ Parkmor Rd.	3:33
3	Las Virgenes Rd. @ Bravo Ln.	3:34
4	Ruthwood Dr. @ Veva Way	3:35
5	Ruthwood Dr. @ Parkmor Rd.	3:36
6	Parkmor Rd. @ Roymor Rd.	3:37
7	Parkmor Rd @ Adamor Rd.	3:38
8	Parkmor Rd. @ Alizia Canyon Dr.	3:40
9	Las Virgenes Rd. @ Thousand Oaks Blvd. (SW)	3:43
10	Las Virgenes Rd. @ Willow Glen St.	3:49
11	Meadow Creek Ln. @ Poppyseed Pl.	3:50
12	Meadow Creek Ln. @ Oleander	3:51
13	Lost Hills Rd. @ Cold Spring St.	3:52
14	Calabasas Hills Rd. @ Peacock Ridge Rd.	3:53
15	Lost Hills Rd. @ Malibu Hills Rd.	3:54
16	Parkville Rd. @ Calamine Dr.	3:56
17	Helmond Dr. @ Ludgate Dr.	3:57
18	Canwood St. @ Ambridge Dr.	4:00

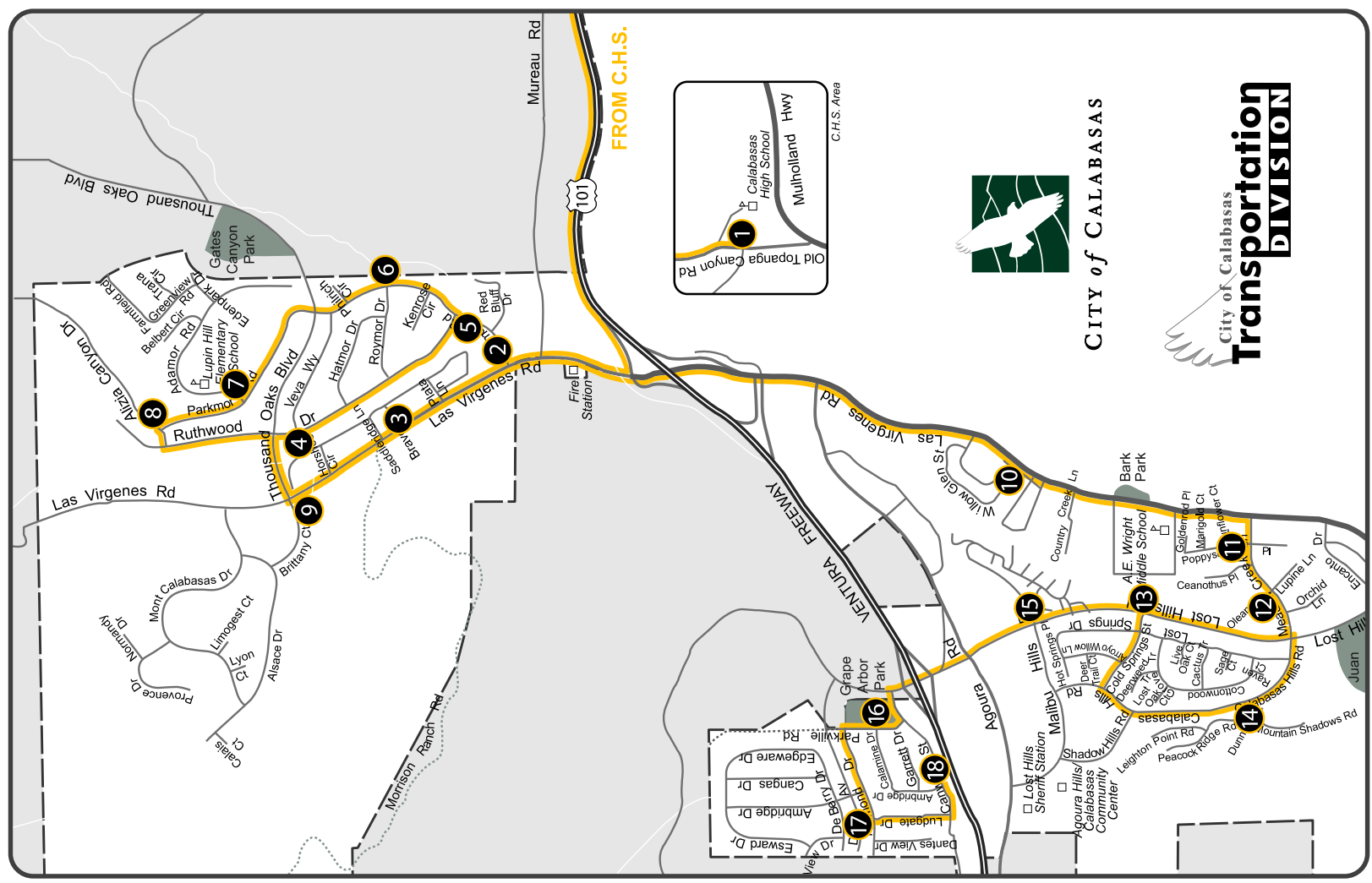

CITY of CALABASAS

City of Calabasas
**Transportation
DIVISION**

**CALABASAS PUBLIC
TRANSPORTATION
SHUTTLE SERVICE
SUMMER
LINE**

2 AM PM

Service: June 17 – July 24

Hours of operation:

- Monday - Thursday
- Transit Pass required.
- No service on holidays.
- Subject to change without notice.

Public Information Available:

Calabasas Transportation
Customer Service
(805) 557-7372

www.cityofcalabasas.com

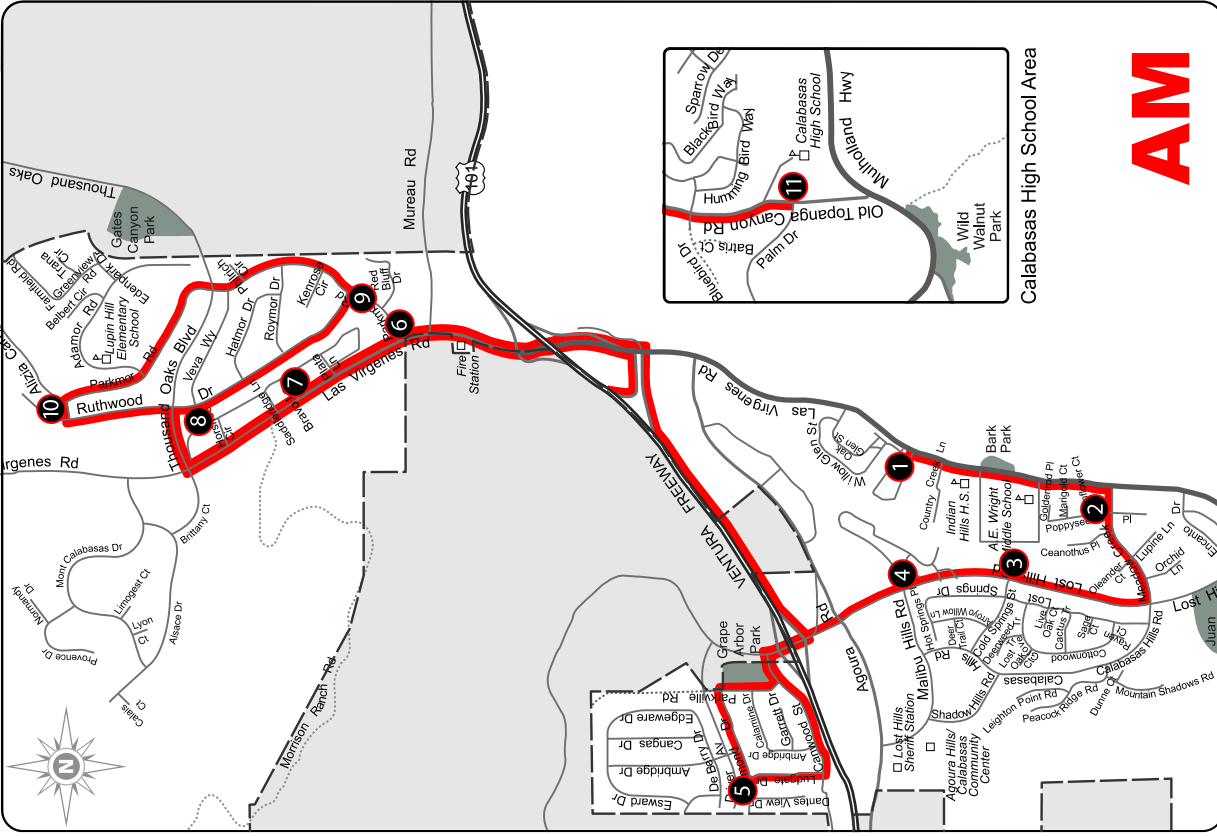

AM

STOP	LOCATION	TIMES
1	Las Virgenes Rd. @ Willow Glen St.	6:32
2	Meadow Creek Ln. @ Poppyseed Pl.	6:34
3	Lost Hills Rd. @ Cold Springs St.	6:36
4	Lost Hills Rd. @ Malibu Hills Rd.	6:38
5	Helmond Dr. @ Ludgate Dr.	6:41
6	Las Virgenes Rd. @ Parkmor Rd.	6:46
7	Las Virgenes Rd. @ Bravo Ln.	6:48
8	Ruthwood Dr. @ Veva Way	6:50
9	Ruthwood Dr. @ Parkmor Rd.	6:52
10	Parkmor Rd. @ Alizia Canyon Dr.	6:55
11	Old Topanga Canyon Rd. @ C.H.S.	7:10

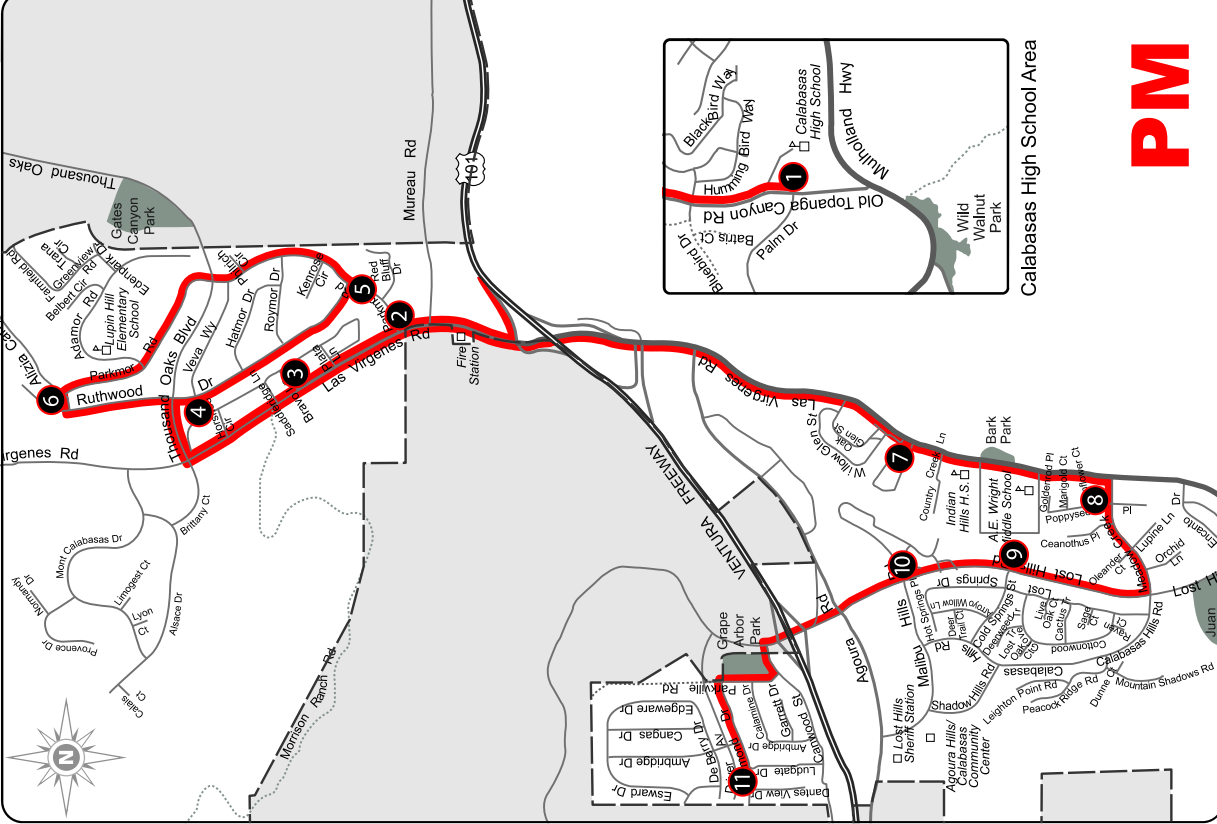

PM

STOP	LOCATION	TIMES
1	Old Topanga Canyon Rd. @ C.H.S.	1:00
2	Las Virgenes Rd. @ Parkmor Rd.	1:15
3	Las Virgenes Rd. @ Bravo Ln.	1:17
4	Ruthwood Dr. @ Veva Way	1:19
5	Ruthwood Dr. @ Parkmor Rd.	1:21
6	Parkmor Rd. @ Alizia Canyon Dr.	1:24
7	Las Virgenes Rd. @ Willow Glen St.	1:30
8	Meadow Creek Ln. @ Poppyseed Pl.	1:32
9	Lost Hills Rd. @ Cold Springs St.	1:34
10	Lost Hills Rd. @ Malibu Hills Rd.	1:36
11	Helmond Dr. @ Ludgate Dr.	1:40

Updated: May 2014

APPENDIX D

TRAFFIC VOLUME DATA

Intersection Turning Movement

Prepared by:

National Data & Surveying Services

Project ID: 14-5572-001

Day: Thursday

City: Calabasas

TOTALS

Date: 9/11/2014

AM

NS/EW Streets:	Las Virgenes Rd			Las Virgenes Rd			Mureau Rd			Mureau Rd			TOTAL
	NORTHBOUND			SOUTHBOUND			EASTBOUND			WESTBOUND			
LANES:	NL	NT	NR	SL	ST	SR	EL	ET	ER	WL	WT	WR	
7:00 AM	0	141	33	11	115	0	0	0	0	32	0	2	334
7:15 AM	0	129	45	17	170	0	0	0	0	29	0	3	393
7:30 AM	0	188	69	23	188	0	0	0	0	39	0	5	512
7:45 AM	0	107	57	20	249	0	0	0	0	55	0	9	497
8:00 AM	0	136	41	22	241	0	0	0	0	66	0	10	516
8:15 AM	1	109	46	10	186	0	0	0	0	57	0	6	415
8:30 AM	1	114	54	5	132	0	0	0	0	60	0	3	369
8:45 AM	0	110	42	12	106	0	0	0	0	42	0	6	318

UTURNS			
NB	SB	EB	WB

TOTAL VOLUMES :	NL	NT	NR	SL	ST	SR	EL	ET	ER	WL	WT	WR	TOTAL
APPROACH %'s :	2	1034	387	120	1387	0	0	0	0	380	0	44	3354
	0.14%	72.66%	27.20%	7.96%	92.04%	0.00%	#DIV/0!	#DIV/0!	#DIV/0!	89.62%	0.00%	10.38%	

NB	SB	EB	WB
0	0	0	0

PEAK HR START TIME :	7:30 AM												TOTAL
PEAK HR VOL :	1	540	213	75	864	0	0	0	0	217	0	30	1940
PEAK HR FACTOR :	0.733			0.873			0.000			0.813			0.940

CONTROL : Signalized

Intersection Turning Movement

Prepared by:

National Data & Surveying Services

Project ID: 14-5572-001

Day: Thursday

City: Calabasas

TOTALS

Date: 9/11/2014

PM

NS/EW Streets:	Las Virgenes Rd			Las Virgenes Rd			Mureau Rd			Mureau Rd			TOTAL
	NORTHBOUND			SOUTHBOUND			EASTBOUND			WESTBOUND			
LANES:	NL	NT	NR	SL	ST	SR	EL	ET	ER	WL	WT	WR	
4:00 PM	0	134	126	17	80	0	0	0	0	48	0	6	411
4:15 PM	1	146	132	23	61	0	0	0	0	41	0	13	417
4:30 PM	0	121	155	20	74	0	0	0	0	54	0	5	429
4:45 PM	0	156	116	26	104	0	0	0	0	49	0	14	465
5:00 PM	0	125	158	17	92	0	0	0	0	66	0	13	471
5:15 PM	0	138	154	27	72	0	0	0	0	34	0	8	433
5:30 PM	0	130	158	19	84	0	0	0	0	55	0	15	461
5:45 PM	0	134	163	11	69	0	0	0	0	47	0	6	430
TOTAL VOLUMES :	NL	NT	NR	SL	ST	SR	EL	ET	ER	WL	WT	WR	TOTAL
APPROACH %'s :	0.04%	48.24%	51.71%	20.10%	79.90%	0.00%	#DIV/0!	#DIV/0!	#DIV/0!	83.12%	0.00%	16.88%	3517
PEAK HR START TIME :	445 PM												TOTAL
PEAK HR VOL :	0	549	586	89	352	0	0	0	0	204	0	50	1830
PEAK HR FACTOR :	0.972			0.848			0.000			0.804			0.971

CONTROL : Signalized

UTURNS			
NB	SB	EB	WB

NB	SB	EB	WB
0	0	0	0

ITM Peak Hour Summary

Prepared by:



National Data & Surveying Services

Las Virgenes Rd and Mureau Rd, Calabasas

Date: 9/11/2014

Day: Thursday

Project #: 14-5572-001

City: Calabasas

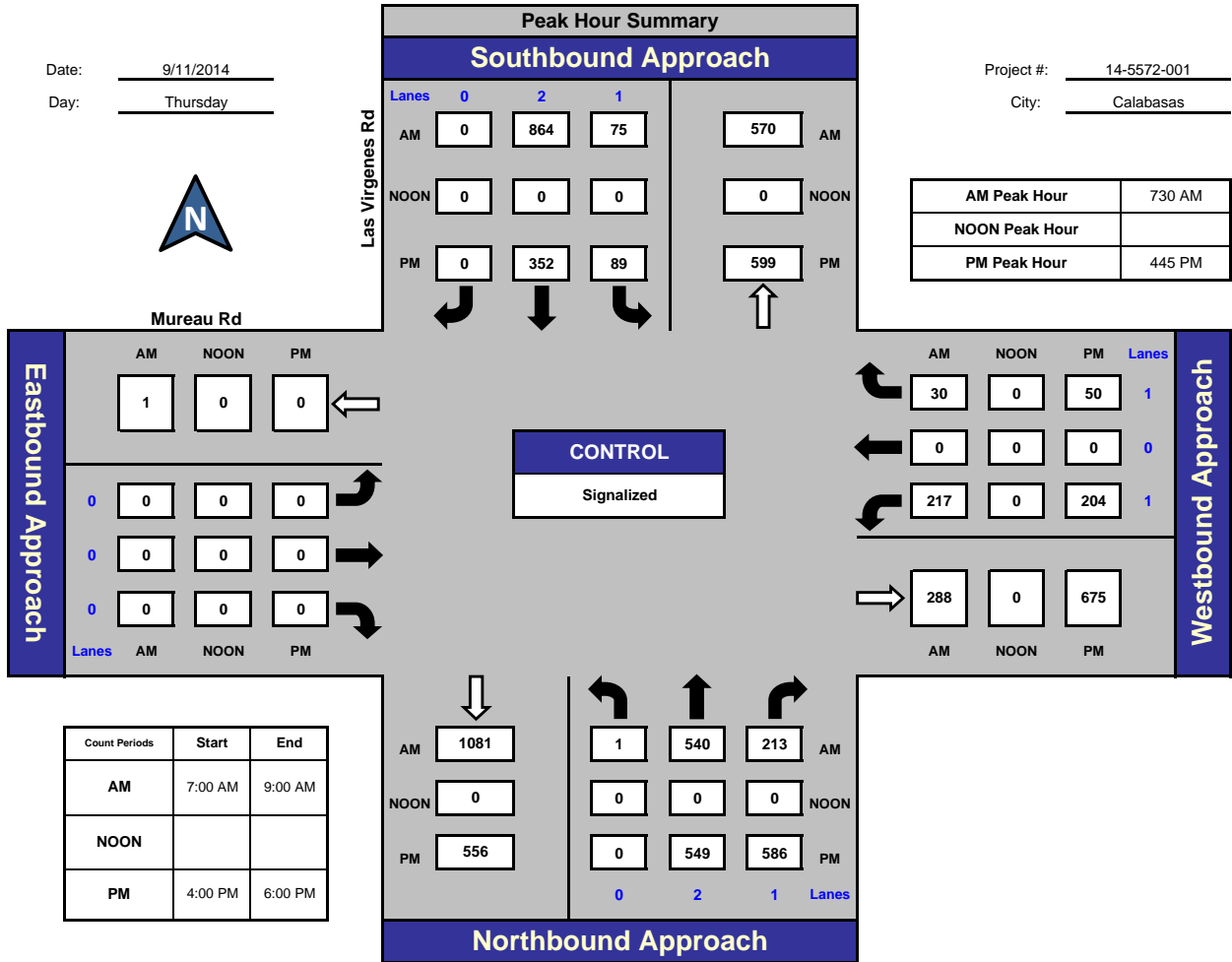

Total Ins & Outs

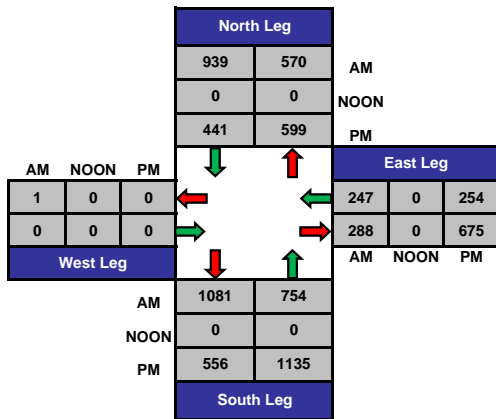

Total Volume Per Leg

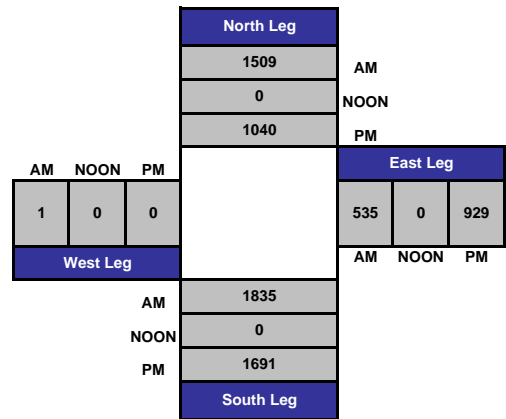

Intersection Turning Movement

Prepared by:

National Data & Surveying Services

Project ID: 14-5572-001

Day: Thursday

City: Calabasas

Cars

Date: 9/11/2014

AM

NS/EW Streets:	Las Virgenes Rd			Las Virgenes Rd			Mureau Rd			Mureau Rd			TOTAL
	NORTHBOUND			SOUTHBOUND			EASTBOUND			WESTBOUND			
LANES:	NL	NT	NR	SL	ST	SR	EL	ET	ER	WL	WT	WR	
7:00 AM	0	141	32	11	115	0	0	0	0	32	0	2	333
7:15 AM	0	129	45	17	170	0	0	0	0	29	0	3	393
7:30 AM	0	188	68	23	188	0	0	0	0	39	0	5	511
7:45 AM	0	107	55	20	248	0	0	0	0	55	0	8	493
8:00 AM	0	136	41	22	241	0	0	0	0	66	0	10	516
8:15 AM	1	109	46	10	186	0	0	0	0	57	0	6	415
8:30 AM	1	114	54	5	132	0	0	0	0	60	0	3	369
8:45 AM	0	109	42	12	106	0	0	0	0	42	0	5	316
TOTAL VOLUMES :	NL	NT	NR	SL	ST	SR	EL	ET	ER	WL	WT	WR	TOTAL
APPROACH %'s :	2	1033	383	120	1386	0	0	0	0	380	0	42	3346
	0.14%	72.85%	27.01%	7.97%	92.03%	0.00%	#DIV/0!	#DIV/0!	#DIV/0!	90.05%	0.00%	9.95%	
PEAK HR START TIME :	730 AM												TOTAL
PEAK HR VOL :	1	540	210	75	863	0	0	0	0	217	0	29	1935
PEAK HR FACTOR :	0.733			0.875			0.000			0.809			0.938

UTURNS			
NB	SB	EB	WB
0	0	0	0

NB	SB	EB	WB
0	0	0	0

CONTROL : Signalized

Intersection Turning Movement

Prepared by:

National Data & Surveying Services

Project ID: 14-5572-001

Day: Thursday

City: Calabasas

Cars

Date: 9/11/2014

PM

NS/EW Streets:	Las Virgenes Rd			Las Virgenes Rd			Mureau Rd			Mureau Rd			TOTAL
	NORTHBOUND			SOUTHBOUND			EASTBOUND			WESTBOUND			
LANES:	NL	NT	NR	SL	ST	SR	EL	ET	ER	WL	WT	WR	
4:00 PM	0	134	126	17	79	0	0	0	0	48	0	6	410
4:15 PM	1	145	132	23	61	0	0	0	0	41	0	13	416
4:30 PM	0	121	155	20	74	0	0	0	0	54	0	5	429
4:45 PM	0	156	116	26	104	0	0	0	0	49	0	14	465
5:00 PM	0	125	158	17	92	0	0	0	0	66	0	13	471
5:15 PM	0	138	154	27	72	0	0	0	0	34	0	8	433
5:30 PM	0	130	158	19	83	0	0	0	0	55	0	15	460
5:45 PM	0	134	163	11	69	0	0	0	0	47	0	6	430
TOTAL VOLUMES :	NL	NT	NR	SL	ST	SR	EL	ET	ER	WL	WT	WR	TOTAL
APPROACH %'s :	0.04%	48.22%	51.74%	20.15%	79.85%	0.00%	#DIV/0!	#DIV/0!	#DIV/0!	83.12%	0.00%	16.88%	3514
PEAK HR START TIME :	4:45 PM												TOTAL
PEAK HR VOL :	0	549	586	89	351	0	0	0	0	204	0	50	1829
PEAK HR FACTOR :	0.972			0.846			0.000			0.804			0.971

CONTROL : Signalized

UTURNS			
NB	SB	EB	WB

NB	SB	EB	WB
0	0	0	0

Intersection Turning Movement

Prepared by:

National Data & Surveying Services

Project ID: 14-5572-001

Day: Thursday

City: Calabasas

3 Axle+ Trucks

Date: 9/11/2014

AM													
NS/EW Streets:	Las Virgenes Rd			Las Virgenes Rd			Mureau Rd			Mureau Rd			
	NORTHBOUND			SOUTHBOUND			EASTBOUND			WESTBOUND			
LANES:	NL	NT	NR	SL	ST	SR	EL	ET	ER	WL	WT	WR	TOTAL
7:00 AM	0	0	1	0	0	0	0	0	0	0	0	0	1
7:15 AM	0	0	0	0	0	0	0	0	0	0	0	0	0
7:30 AM	0	0	1	0	0	0	0	0	0	0	0	0	1
7:45 AM	0	0	2	0	1	0	0	0	0	0	0	1	4
8:00 AM	0	0	0	0	0	0	0	0	0	0	0	0	0
8:15 AM	0	0	0	0	0	0	0	0	0	0	0	0	0
8:30 AM	0	0	0	0	0	0	0	0	0	0	0	0	0
8:45 AM	0	1	0	0	0	0	0	0	0	0	0	1	2
TOTAL VOLUMES :	NL	NT	NR	SL	ST	SR	EL	ET	ER	WL	WT	WR	TOTAL
APPROACH %'s :	0	1	4	0	1	0	0	0	0	0	0	2	8
	0.00%	20.00%	80.00%	0.00%	100.00%	0.00%	#DIV/0!	#DIV/0!	#DIV/0!	0.00%	0.00%	100.00%	
PEAK HR START TIME :	7:30 AM												TOTAL
PEAK HR VOL :	0 0 3			0 1 0			0 0 0			0 0 1			5
PEAK HR FACTOR :	0.375			0.250			0.000			0.250			0.938

UTURNS			
NB	SB	EB	WB

NB	SB	EB	WB
0	0	0	0

CONTROL : Signalized

Intersection Turning Movement

Prepared by:

National Data & Surveying Services

Project ID: 14-5572-001

Day: Thursday

City: Calabasas

3 Axle+ Trucks

Date: 9/11/2014

PM

NS/EW Streets:	Las Virgenes Rd		Las Virgenes Rd			Mureau Rd			Mureau Rd			TOTAL	
	NORTHBOUND			SOUTHBOUND			EASTBOUND			WESTBOUND			
LANES:	NL	NT	NR	SL	ST	SR	EL	ET	ER	WL	WT	WR	
4:00 PM	0	0	0	0	1	0	0	0	0	0	0	0	1
4:15 PM	0	1	0	0	0	0	0	0	0	0	0	0	1
4:30 PM	0	0	0	0	0	0	0	0	0	0	0	0	0
4:45 PM	0	0	0	0	0	0	0	0	0	0	0	0	0
5:00 PM	0	0	0	0	0	0	0	0	0	0	0	0	0
5:15 PM	0	0	0	0	0	0	0	0	0	0	0	0	0
5:30 PM	0	0	0	0	1	0	0	0	0	0	0	0	1
5:45 PM	0	0	0	0	0	0	0	0	0	0	0	0	0
TOTAL VOLUMES :	NL	NT	NR	SL	ST	SR	EL	ET	ER	WL	WT	WR	TOTAL
APPROACH %'s :	0	1	0	0	2	0	0	0	0	0	0	0	3
	0.00%	100.00%	0.00%	0.00%	100.00%	0.00%	#DIV/0!	#DIV/0!	#DIV/0!	#DIV/0!	#DIV/0!	#DIV/0!	
PEAK HR START TIME :	445 PM												TOTAL
PEAK HR VOL :	0	0	0	0	1	0	0	0	0	0	0	0	1
PEAK HR FACTOR :	0.000			0.250			0.000			0.000			0.971

UTURNS			
NB	SB	EB	WB
0	0	0	0

NB	SB	EB	WB
0	0	0	0

CONTROL : Signalized

PREPARED BY NATIONAL DATA & SURVEYING SERVICES

PROJECT#: 14-5572-001
 N/S Street: Las Virgenes
 E/W Street: Mureau Rd
 DATE: 9/11/2014
 CITY: Calabasas

DAY: Thursday

A M

PEDESTRIANS

T I M E	NORTH LEG		SOUTH LEG		EAST LEG		WEST LEG	
	EB	WB	EB	WB	NB	SB	NB	SB
7:00 AM	0	0	0	0	3	2	0	0
7:15 AM	1	0	0	0	4	2	0	0
7:30 AM	0	0	0	0	2	0	0	0
7:45 AM	0	0	0	0	5	2	0	0
8:00 AM	0	0	0	0	0	0	0	0
8:15 AM	0	0	0	0	1	0	0	0
8:30 AM	0	0	0	0	0	0	0	0
8:45 AM	0	0	0	0	0	2	0	0
TOTALS	1	0	0	0	15	8	0	0

BIKES

T I M E	NB			SB			EB			WB		
	NL	NT	NR	SL	ST	SR	EL	ET	ER	WL	WT	WR
7:00 AM	0	0	0	0	0	0	0	0	0	0	0	0
7:15 AM	0	0	0	0	0	0	0	0	0	0	0	0
7:30 AM	0	0	2	0	2	0	0	0	0	1	0	0
7:45 AM	0	0	1	0	1	0	0	0	0	0	0	0
8:00 AM	0	0	0	0	0	0	0	0	0	0	0	0
8:15 AM	0	0	0	0	0	0	0	0	0	2	0	0
8:30 AM	0	0	0	0	0	0	0	0	0	0	0	0
8:45 AM	0	0	0	0	0	0	0	0	0	0	0	0
TOTALS	0	0	3	0	3	0	0	0	0	3	0	0

P M

PEDESTRIANS

T I M E	NORTH LEG		SOUTH LEG		EAST LEG		WEST LEG	
	EB	WB	EB	WB	NB	SB	NB	SB
4:00 PM	0	0	0	0	0	1	0	0
4:15 PM	0	0	0	0	0	0	0	0
4:30 PM	0	0	0	0	0	0	0	0
4:45 PM	0	0	0	0	0	0	0	0
5:00 PM	0	0	0	0	0	0	0	0
5:15 PM	0	0	0	0	0	1	0	0
5:30 PM	0	0	0	0	0	0	0	0
5:45 PM	0	0	0	0	0	0	0	0
TOTALS	0	0	0	0	0	2	0	0

BIKES

T I M E	NB			SB			EB			WB		
	NL	NT	NR	SL	ST	SR	EL	ET	ER	WL	WT	WR
4:00 PM	0	0	0	0	0	0	0	0	0	0	0	0
4:15 PM	0	1	0	0	0	0	0	0	0	2	0	0
4:30 PM	0	0	0	0	0	0	0	0	0	1	0	0
4:45 PM	0	0	0	0	0	0	0	0	0	0	0	0
5:00 PM	0	0	0	0	0	0	0	0	0	0	0	0
5:15 PM	0	0	0	0	0	0	0	0	0	0	0	0
5:30 PM	0	0	1	0	0	0	0	0	0	1	0	0
5:45 PM	0	0	1	0	0	0	0	0	0	0	0	0
TOTALS	0	1	2	0	0	0	0	0	0	4	0	0

Intersection Turning Movement

Prepared by:

National Data & Surveying Services

Project ID: 14-5572-003

Day: Thursday

City: Calabasas

TOTALS

Date: 9/11/2014

AM

NS/EW Streets:	Las Virgenes Rd			Las Virgenes Rd			US-101 NB Ramps			US-101 NB Ramps			TOTAL
	NORTHBOUND			SOUTHBOUND			EASTBOUND			WESTBOUND			
LANES:	NL	NT	NR	SL	ST	SR	EL	ET	ER	WL	WT	WR	
	0	2	1	1	2	1	0.5	0.5	1	0	1	0	
7:00 AM	0	100	0	8	263	48	39	2	87	0	0	4	32
7:15 AM	0	149	0	3	305	62	88	0	98	1	0	8	66
7:30 AM	0	237	0	7	265	65	83	0	61	2	2	5	143
7:45 AM	0	122	0	7	286	91	54	2	80	1	0	11	58
8:00 AM	0	173	1	5	350	81	55	0	70	1	0	12	74
8:15 AM	0	205	0	7	381	78	47	2	80	2	0	10	67
8:30 AM	0	236	0	6	337	50	52	1	73	4	0	11	80
8:45 AM	0	157	0	4	252	39	42	1	67	1	0	4	52

TOTAL VOLUMES :	NL	NT	NR	SL	ST	SR	EL	ET	ER	WL	WT	WR	TOTAL
APPROACH %'s :	0.00%	99.93%	0.07%	1.57%	81.30%	17.13%	42.44%	0.74%	56.83%	15.19%	2.53%	82.28%	5543

PEAK HR START TIME :	745 AM												TOTAL
PEAK HR VOL :	0	736	1	25	1354	300	208	5	303	8	0	44	2984
PEAK HR FACTOR :	0.781			0.901			0.949			0.867			0.919

CONTROL : Signalized

UTURNS			
NB	SB	EB	WB
	5		
	1		
	6		
	4		
	3		
	5		
	3		
	1		
NB	0	SB	28
EB	0	WB	0

Intersection Turning Movement

Prepared by:

National Data & Surveying Services

Project ID: 14-5572-003

Day: Thursday

City: Calabasas

TOTALS

Date: 9/11/2014

NS/EW Streets:	PM												TOTAL
	Las Virgenes Rd			Las Virgenes Rd			US-101 NB Ramps			US-101 NB Ramps			
	NORTHBOUND			SOUTHBOUND			EASTBOUND			WESTBOUND			
LANES:	NL	NT	NR	SL	ST	SR	EL	ET	ER	WL	WT	WR	TOTAL
	0	2	1	1	2	1	0.5	0.5	1	0	1	0	
4:00 PM	0	341	0	5	161	30	109	2	35	2	0	13	146
4:15 PM	0	357	1	15	129	22	101	2	28	3	0	6	177
4:30 PM	0	343	1	8	128	34	107	1	42	5	0	11	164
4:45 PM	0	347	0	9	158	32	90	0	28	5	0	16	167
5:00 PM	0	366	1	10	162	34	132	1	44	2	0	8	180
5:15 PM	1	335	0	11	156	26	128	0	26	3	0	4	167
5:30 PM	0	321	0	13	152	30	120	0	36	3	0	5	161
5:45 PM	0	286	0	3	126	24	135	1	56	1	0	7	134
TOTAL VOLUMES :	NL	NT	NR	SL	ST	SR	EL	ET	ER	WL	WT	WR	TOTAL
APPROACH %'s :	1	2696	3	74	1172	232	922	7	295	24	0	70	5496
	0.04%	99.85%	0.11%	5.01%	79.30%	15.70%	75.33%	0.57%	24.10%	25.53%	0.00%	74.47%	
PEAK HR START TIME :	445 PM												TOTAL
PEAK HR VOL :	1	1369	1	43	628	122	470	1	134	13	0	33	2815
PEAK HR FACTOR :	0.934			0.962			0.855			0.548			0.926

UTURNS			
NB	SB	EB	WB
	1		
	11		
	3		
	5		
	7		
	7		
	9		
	2		

NB	SB	EB	WB
0	45	0	0

CONTROL : Signalized

ITM Peak Hour Summary

Prepared by:



National Data & Surveying Services

Las Virgenes Rd and US-101 NB Ramps, Calabasas

Date: 9/11/2014
Day: Thursday

Project #: 14-5572-003
City: Calabasas

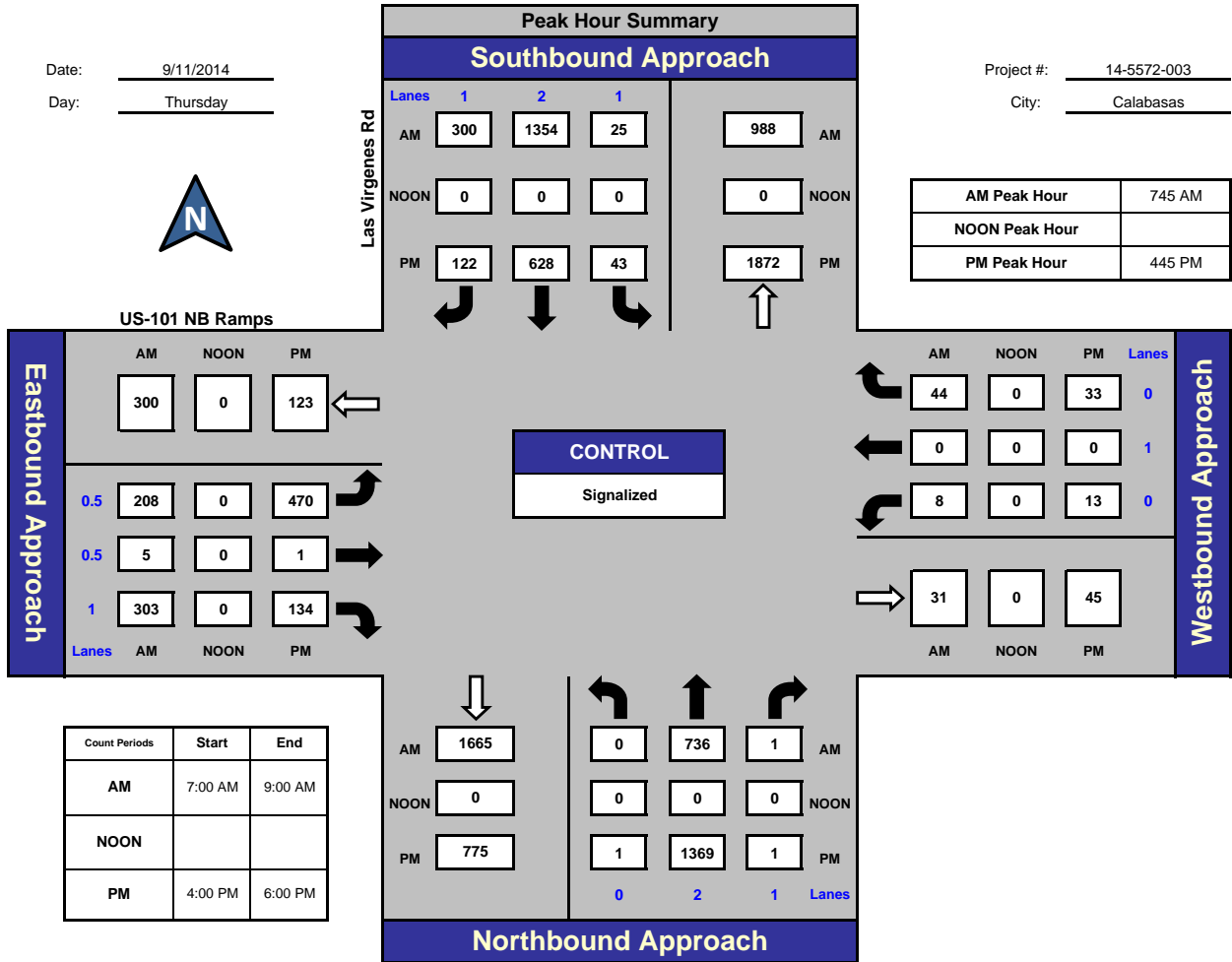

Total Ins & Outs

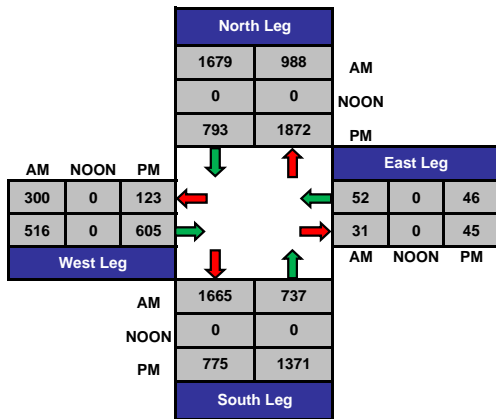

Total Volume Per Leg

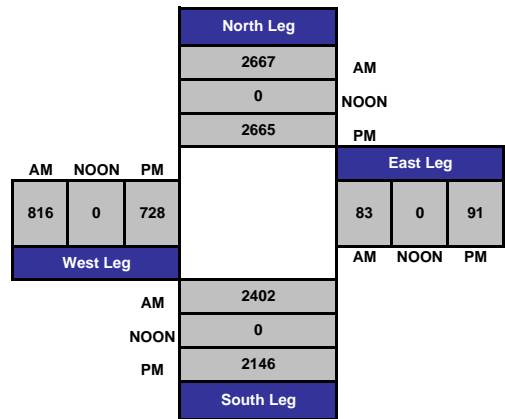

Intersection Turning Movement

Prepared by:

National Data & Surveying Services

Project ID: 14-5572-003

Day: Thursday

City: Calabasas

Cars

Date: 9/11/2014

AM

NS/EW Streets:	Las Virgenes Rd			Las Virgenes Rd			US-101 NB Ramps			US-101 NB Ramps			TOTAL
	NORTHBOUND			SOUTHBOUND			EASTBOUND			WESTBOUND			
LANES:	NL	NT	NR	SL	ST	SR	EL	ET	ER	WL	WT	WR	
	0	2	1	1	2	1	0.5	0.5	1	0	1	0	
7:00 AM	0	100	0	8	263	48	38	2	87	0	0	4	32
7:15 AM	0	149	0	3	305	62	88	0	98	1	0	8	66
7:30 AM	0	235	0	7	265	65	83	0	61	2	2	5	143
7:45 AM	0	122	0	7	286	91	54	2	80	1	0	10	58
8:00 AM	0	171	1	5	350	81	55	0	70	1	0	12	74
8:15 AM	0	204	0	7	381	78	47	2	80	2	0	10	67
8:30 AM	0	235	0	6	336	50	51	1	73	4	0	11	80
8:45 AM	0	156	0	4	252	38	42	1	67	1	0	4	52
TOTAL VOLUMES :	NL	NT	NR	SL	ST	SR	EL	ET	ER	WL	WT	WR	TOTAL
APPROACH %'s :	0	1372	1	47	2438	513	458	8	616	12	2	64	5531
	0.00%	99.93%	0.07%	1.57%	81.32%	17.11%	42.33%	0.74%	56.93%	15.38%	2.56%	82.05%	
PEAK HR START TIME :	745 AM												TOTAL
PEAK HR VOL :	0	732	1	25	1353	300	207	5	303	8	0	43	2977
PEAK HR FACTOR :	0.780			0.900			0.947			0.850			0.918

UTURNS			
NB	SB	EB	WB
	5		
	1		
	6		
	4		
	3		
	5		
	3		
	1		
NB	SB	EB	WB
0	28	0	0

CONTROL : Signalized

Intersection Turning Movement

Prepared by:

National Data & Surveying Services

Project ID: 14-5572-003

Day: Thursday

City: Calabasas

Cars

Date: 9/11/2014

PM

NS/EW Streets:	Las Virgenes Rd			Las Virgenes Rd			US-101 NB Ramps			US-101 NB Ramps			TOTAL
	NORTHBOUND			SOUTHBOUND			EASTBOUND			WESTBOUND			
LANES:	NL	NT	NR	SL	ST	SR	EL	ET	ER	WL	WT	WR	
	0	2	1	1	2	1	0.5	0.5	1	0	1	0	
4:00 PM	0	341	0	5	160	29	109	2	35	2	0	13	146
4:15 PM	0	356	1	15	129	22	101	2	28	3	0	6	177
4:30 PM	0	341	1	8	128	34	107	1	42	5	0	11	164
4:45 PM	0	346	0	9	158	32	90	0	28	5	0	16	167
5:00 PM	0	364	1	10	162	34	132	1	44	2	0	8	180
5:15 PM	1	335	0	11	154	26	128	0	26	3	0	4	167
5:30 PM	0	321	0	13	152	29	120	0	36	3	0	5	161
5:45 PM	0	286	0	3	126	24	135	1	56	1	0	7	134

TOTAL VOLUMES :	NL	NT	NR	SL	ST	SR	EL	ET	ER	WL	WT	WR	TOTAL
APPROACH %'s :	0.04%	99.85%	0.11%	5.02%	79.36%	15.61%	75.33%	0.57%	24.10%	25.53%	0.00%	74.47%	5485

PEAK HR START TIME :	445 PM												TOTAL
PEAK HR VOL :	1	1366	1	43	626	121	470	1	134	13	0	33	2809
PEAK HR FACTOR :	0.937			0.959			0.855			0.548			0.926

CONTROL : Signalized

UTURNS			
NB	SB	EB	WB
	1		
	11		
	3		
	5		
	7		
	7		
	9		
	2		
NB	0	SB	45
EB	0	WB	0

Intersection Turning Movement

Prepared by:

National Data & Surveying Services

Project ID: 14-5572-003

Day: Thursday

City: Calabasas

3 Axle+ Trucks

Date: 9/11/2014

AM													
NS/EW Streets:	Las Virgenes Rd			Las Virgenes Rd			US-101 NB Ramps			US-101 NB Ramps			
	NORTHBOUND			SOUTHBOUND			EASTBOUND			WESTBOUND			
LANES:	NL	NT	NR	SL	ST	SR	EL	ET	ER	WL	WT	WR	TOTAL
7:00 AM	0	0	0	0	0	0	1	0	0	0	0	0	32
7:15 AM	0	0	0	0	0	0	0	0	0	0	0	0	66
7:30 AM	0	2	0	0	0	0	0	0	0	0	0	0	143
7:45 AM	0	0	0	0	0	0	0	0	0	0	0	1	58
8:00 AM	0	2	0	0	0	0	0	0	0	0	0	0	74
8:15 AM	0	1	0	0	0	0	0	0	0	0	0	0	67
8:30 AM	0	1	0	0	1	0	1	0	0	0	0	0	80
8:45 AM	0	1	0	0	0	1	0	0	0	0	0	0	52
TOTAL VOLUMES :	NL	NT	NR	SL	ST	SR	EL	ET	ER	WL	WT	WR	TOTAL
APPROACH %'s :	0	7	0	0	1	1	2	0	0	0	0	1	12
	0.00%	100.00%	0.00%	0.00%	50.00%	50.00%	100.00%	0.00%	0.00%	0.00%	0.00%	100.00%	
PEAK HR START TIME :	745 AM												TOTAL
PEAK HR VOL :	0	4	0	0	1	0	1	0	0	0	0	1	7
PEAK HR FACTOR :	0.500			0.250			0.250			0.250			0.918

UTURNS			
NB	SB	EB	WB

NB	SB	EB	WB
0	0	0	0

CONTROL : Signalized

Intersection Turning Movement

Prepared by:

National Data & Surveying Services

Project ID: 14-5572-003

Day: Thursday

City: Calabasas

3 Axle+ Trucks

Date: 9/11/2014

PM

NS/EW Streets:	Las Virgenes Rd		Las Virgenes Rd			US-101 NB Ramps			US-101 NB Ramps			TOTAL	
	NORTHBOUND			SOUTHBOUND			EASTBOUND			WESTBOUND			
LANES:	NL	NT	NR	SL	ST	SR	EL	ET	ER	WL	WT	WR	
	0	2	1	1	2	1	0.5	0.5	1	0	1	0	
4:00 PM	0	0	0	0	1	1	0	0	0	0	0	0	146
4:15 PM	0	1	0	0	0	0	0	0	0	0	0	0	177
4:30 PM	0	2	0	0	0	0	0	0	0	0	0	0	164
4:45 PM	0	1	0	0	0	0	0	0	0	0	0	0	167
5:00 PM	0	2	0	0	0	0	0	0	0	0	0	0	180
5:15 PM	0	0	0	0	2	0	0	0	0	0	0	0	167
5:30 PM	0	0	0	0	0	1	0	0	0	0	0	0	161
5:45 PM	0	0	0	0	0	0	0	0	0	0	0	0	134
TOTAL VOLUMES :	NL	NT	NR	SL	ST	SR	EL	ET	ER	WL	WT	WR	TOTAL
APPROACH %'s :	0	6	0	0	3	2	0	0	0	0	0	0	11
	0.00%	100.00%	0.00%	0.00%	60.00%	40.00%	#DIV/0!	#DIV/0!	#DIV/0!	#DIV/0!	#DIV/0!	#DIV/0!	
PEAK HR START TIME :	445 PM												TOTAL
PEAK HR VOL :	0	3	0	0	2	1	0	0	0	0	0	0	6
PEAK HR FACTOR :	0.375			0.375			0.000			0.000			0.926

UTURNS			
NB	SB	EB	WB

NB	SB	EB	WB
0	0	0	0

CONTROL : Signalized

Intersection Turning Movement

Prepared by:

National Data & Surveying Services

Project ID: 14-5572-002

Day: Thursday

City: Calabasas

TOTALS

Date: 9/11/2014

AM

NS/EW Streets:	Las Virgenes Rd			Las Virgenes Rd			US-101 SB Ramps			US-101 SB Ramps			TOTAL
	NORTHBOUND			SOUTHBOUND			EASTBOUND			WESTBOUND			
LANES:	NL	NT	NR	SL	ST	SR	EL	ET	ER	WL	WT	WR	
	1	2	0	0	2	1	0	0	0	1.5	0.5	1	
7:00 AM	19	105	0	0	110	51	0	0	0	219	0	61	565
7:15 AM	29	144	0	1	133	60	0	0	0	230	0	81	678
7:30 AM	39	126	0	0	152	90	0	0	0	204	0	77	688
7:45 AM	34	94	0	0	171	130	0	0	0	224	0	71	724
8:00 AM	44	137	0	0	170	125	0	0	0	251	0	68	795
8:15 AM	50	142	0	0	152	101	0	0	0	295	0	48	788
8:30 AM	45	157	0	0	119	67	0	0	0	235	0	41	664
8:45 AM	34	124	0	0	99	55	0	0	0	202	0	60	574
TOTAL VOLUMES :	NL	NT	NR	SL	ST	SR	EL	ET	ER	WL	WT	WR	TOTAL
APPROACH %'s :	294	1059	0	1	1106	679	0	0	0	1860	0	507	5506
	21.73%	78.27%	0.00%	0.06%	61.93%	38.02%	#DIV/0!	#DIV/0!	#DIV/0!	78.58%	0.00%	21.42%	
PEAK HR START TIME :	730 AM												TOTAL
PEAK HR VOL :	167	499	0	0	645	446	0	0	0	974	0	264	2995
PEAK HR FACTOR :	0.867			0.906			0.000			0.902			0.942

UTURNS			
NB	SB	EB	WB
1	0		
0	1		
0	0		
0	0		
0	0		
0	0		
0	0		
0	0		
0	0		
1	1	0	0

CONTROL : Signalized

Intersection Turning Movement

Prepared by:

National Data & Surveying Services

Project ID: 14-5572-002

Day: Thursday

City: Calabasas

TOTALS

Date: 9/11/2014

NS/EW Streets:	PM												TOTAL
	Las Virgenes Rd			Las Virgenes Rd			US-101 SB Ramps			US-101 SB Ramps			
	NORTHBOUND			SOUTHBOUND			EASTBOUND			WESTBOUND			
LANES:	NL	NT	NR	SL	ST	SR	EL	ET	ER	WL	WT	WR	TOTAL
	1	2	0	0	2	1	0	0	0	1.5	0.5	1	
4:00 PM	81	217	0	0	59	54	0	0	0	120	2	68	601
4:15 PM	74	205	0	0	58	55	0	0	0	101	0	64	557
4:30 PM	62	214	0	2	73	65	0	0	0	98	1	49	564
4:45 PM	67	220	0	0	65	85	0	0	0	112	2	49	600
5:00 PM	68	241	0	0	84	71	0	0	0	116	0	48	628
5:15 PM	61	252	0	0	54	48	0	0	0	118	0	53	586
5:30 PM	68	253	0	0	64	75	0	0	0	107	2	50	619
5:45 PM	41	228	0	0	54	54	0	0	0	104	0	45	526
TOTAL VOLUMES :	NL	NT	NR	SL	ST	SR	EL	ET	ER	WL	WT	WR	TOTAL
APPROACH %'s :	522	1830	0	2	511	507	0	0	0	876	7	426	4681
	22.19%	77.81%	0.00%	0.20%	50.10%	49.71%	#DIV/0!	#DIV/0!	#DIV/0!	66.92%	0.53%	32.54%	
PEAK HR START TIME :	445 PM												TOTAL
PEAK HR VOL :	264	966	0	0	267	279	0	0	0	453	4	200	2433
PEAK HR FACTOR :	0.958			0.881			0.000			0.961			0.969

UTURNS			
NB	SB	EB	WB
0	0		
1	0		
0	2		
0	0		
2	0		
0	0		
0	0		
0	0		
0	0		
3	2	0	0

CONTROL : Signalized

ITM Peak Hour Summary

Prepared by:



National Data & Surveying Services

Las Virgenes Rd and US-101 SB Ramps, Calabasas

Date: 9/11/2014

Day: Thursday

Project #: 14-5572-002

City: Calabasas

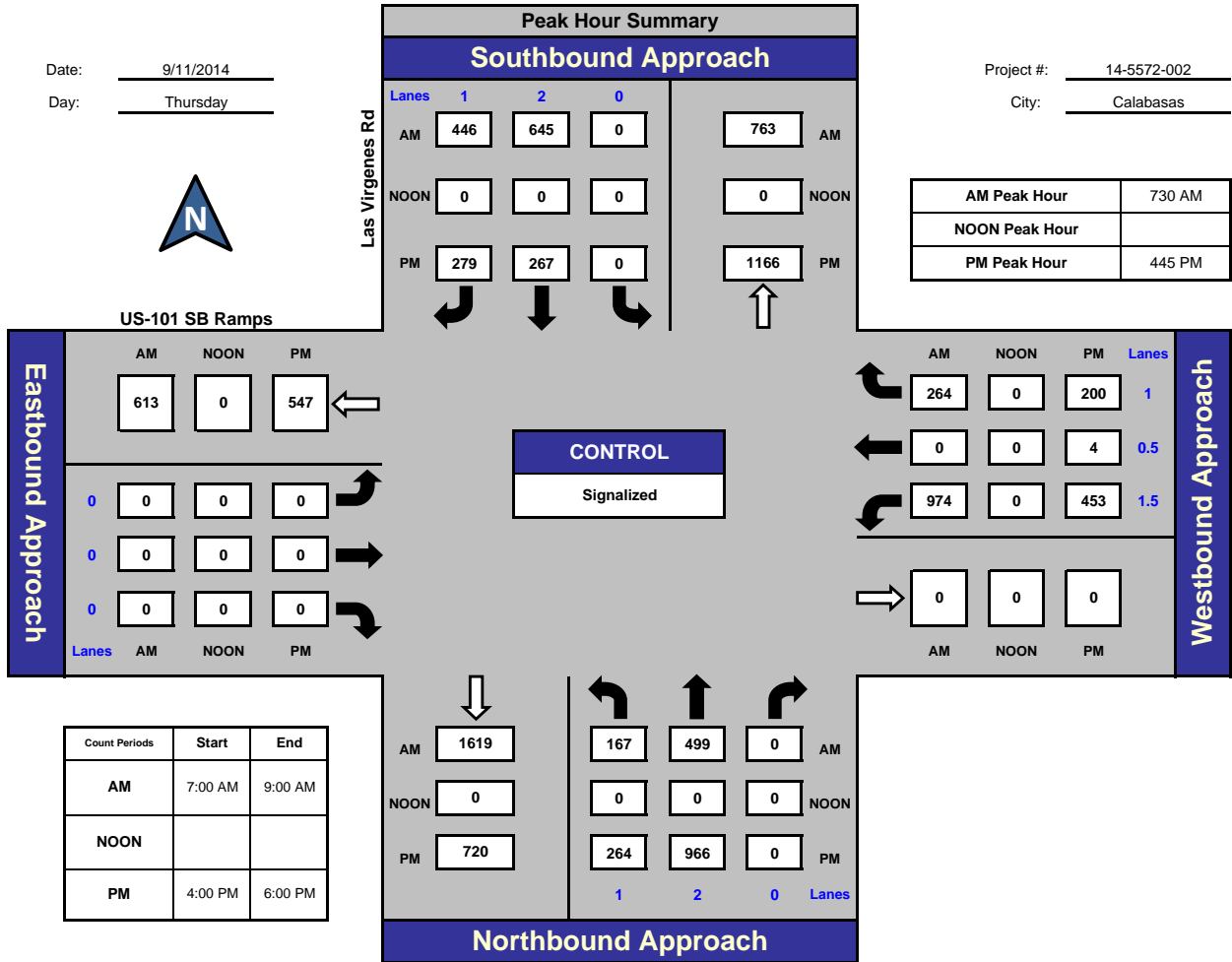

Total Ins & Outs

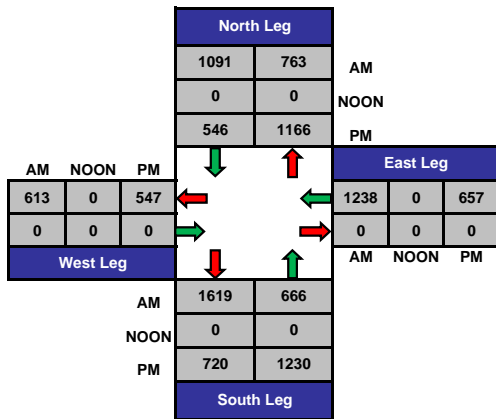

Total Volume Per Leg

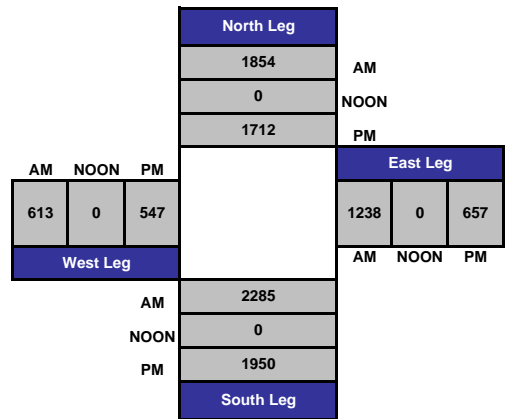

Intersection Turning Movement

Prepared by:

National Data & Surveying Services

Project ID: 14-5572-002

Day: Thursday

City: Calabasas

Cars

Date: 9/11/2014

AM

NS/EW Streets:	Las Virgenes Rd			Las Virgenes Rd			US-101 SB Ramps			US-101 SB Ramps			TOTAL
	NORTHBOUND			SOUTHBOUND			EASTBOUND			WESTBOUND			
LANES:	NL	NT	NR	SL	ST	SR	EL	ET	ER	WL	WT	WR	
	1	2	0	0	2	1	0	0	0	1.5	0.5	1	
7:00 AM	19	105	0	0	110	51	0	0	0	219	0	61	565
7:15 AM	29	144	0	1	133	60	0	0	0	230	0	81	678
7:30 AM	39	124	0	0	152	90	0	0	0	204	0	77	686
7:45 AM	34	94	0	0	171	129	0	0	0	224	0	71	723
8:00 AM	43	137	0	0	170	125	0	0	0	251	0	68	794
8:15 AM	50	142	0	0	152	101	0	0	0	294	0	48	787
8:30 AM	45	156	0	0	119	67	0	0	0	234	0	40	661
8:45 AM	33	124	0	0	99	55	0	0	0	202	0	60	573
TOTAL VOLUMES :	NL	NT	NR	SL	ST	SR	EL	ET	ER	WL	WT	WR	TOTAL
APPROACH %'s :	292	1026	0	1	1106	678	0	0	0	1858	0	506	5467
	22.15%	77.85%	0.00%	0.06%	61.96%	37.98%	#DIV/0!	#DIV/0!	#DIV/0!	78.60%	0.00%	21.40%	
PEAK HR START TIME :	730 AM												TOTAL
PEAK HR VOL :	166	497	0	0	645	445	0	0	0	973	0	264	2990
PEAK HR FACTOR :	0.863			0.908			0.000			0.904			0.941

UTURNS			
NB	SB	EB	WB
1	0		
0	1		
0	0		
0	0		
0	0		
0	0		
0	0		
0	0		
0	0		
0	0		
1	1	0	0

CONTROL : Signalized

Intersection Turning Movement

Prepared by:

National Data & Surveying Services

Project ID: 14-5572-002

Day: Thursday

City: Calabasas

Cars

Date: 9/11/2014

PM

NS/EW Streets:	Las Virgenes Rd			Las Virgenes Rd			US-101 SB Ramps			US-101 SB Ramps			TOTAL
	NORTHBOUND			SOUTHBOUND			EASTBOUND			WESTBOUND			
LANES:	NL	NT	NR	SL	ST	SR	EL	ET	ER	WL	WT	WR	
	1	2	0	0	2	1	0	0	0	1.5	0.5	1	
4:00 PM	80	217	0	0	58	54	0	0	0	119	2	67	597
4:15 PM	74	205	0	0	58	55	0	0	0	101	0	64	557
4:30 PM	61	214	0	2	73	65	0	0	0	98	1	49	563
4:45 PM	67	220	0	0	65	85	0	0	0	112	2	49	600
5:00 PM	68	241	0	0	84	71	0	0	0	115	0	48	627
5:15 PM	61	252	0	0	54	48	0	0	0	117	0	53	585
5:30 PM	68	253	0	0	63	75	0	0	0	106	2	50	617
5:45 PM	41	228	0	0	54	54	0	0	0	104	0	45	526
TOTAL VOLUMES :	NL	NT	NR	SL	ST	SR	EL	ET	ER	WL	WT	WR	TOTAL
APPROACH %'s :	520	1830	0	2	509	507	0	0	0	872	7	425	4672
	22.13%	77.87%	0.00%	0.20%	50.00%	49.80%	#DIV/0!	#DIV/0!	#DIV/0!	66.87%	0.54%	32.59%	
PEAK HR START TIME :	4:45 PM												TOTAL
PEAK HR VOL :	264	966	0	0	266	279	0	0	0	450	4	200	2429
PEAK HR FACTOR :	0.958			0.879			0.000			0.962			0.969

UTURNS			
NB	SB	EB	WB
0	0		
1	0		
0	2		
0	0		
2	0		
0	0		
0	0		
0	0		
0	0		
3	2	0	0

CONTROL : Signalized

Intersection Turning Movement

Prepared by:

National Data & Surveying Services

Project ID: 14-5572-002

Day: Thursday

City: Calabasas

3 Axle+ Trucks

Date: 9/11/2014

AM														
NS/EW Streets:	Las Virgenes Rd			Las Virgenes Rd			US-101 SB Ramps			US-101 SB Ramps				
	NORTHBOUND			SOUTHBOUND			EASTBOUND			WESTBOUND				
LANES:	NL	NT	NR	SL	ST	SR	EL	ET	ER	WL	WT	WR	TOTAL	
7:00 AM	0	0	0	0	0	0	0	0	0	0	0	0	0	0
7:15 AM	0	0	0	0	0	0	0	0	0	0	0	0	0	0
7:30 AM	0	2	0	0	0	0	0	0	0	0	0	0	2	0
7:45 AM	0	0	0	0	0	1	0	0	0	0	0	0	1	0
8:00 AM	1	0	0	0	0	0	0	0	0	0	0	0	1	0
8:15 AM	0	0	0	0	0	0	0	0	0	1	0	0	1	0
8:30 AM	0	1	0	0	0	0	0	0	0	1	0	1	3	0
8:45 AM	1	0	0	0	0	0	0	0	0	0	0	0	1	0
TOTAL VOLUMES :	NL	NT	NR	SL	ST	SR	EL	ET	ER	WL	WT	WR	TOTAL	
APPROACH %'s :	2	3	0	0	0	1	0	0	0	2	0	1	9	
	40.00%	60.00%	0.00%	0.00%	0.00%	100.00%	#DIV/0!	#DIV/0!	#DIV/0!	66.67%	0.00%	33.33%		
PEAK HR START TIME :	730 AM												TOTAL	
PEAK HR VOL :	1	2	0	0	0	1	0	0	0	1	0	0	5	
PEAK HR FACTOR :	0.375			0.250			0.000			0.250			0.941	

UTURNS			
NB	SB	EB	WB

NB	SB	EB	WB
0	0	0	0

CONTROL : Signalized

Intersection Turning Movement

Prepared by:

National Data & Surveying Services

Project ID: 14-5572-002

Day: Thursday

City: Calabasas

3 Axle+ Trucks

Date: 9/11/2014

PM

NS/EW Streets:	Las Virgenes Rd		Las Virgenes Rd			US-101 SB Ramps			US-101 SB Ramps			TOTAL	
	NORTHBOUND			SOUTHBOUND			EASTBOUND			WESTBOUND			
LANES:	NL	NT	NR	SL	ST	SR	EL	ET	ER	WL	WT	WR	
	1	2	0	0	2	1	0	0	0	1.5	0.5	1	
4:00 PM	1	0	0	0	1	0	0	0	0	1	0	1	4
4:15 PM	0	0	0	0	0	0	0	0	0	0	0	0	0
4:30 PM	1	0	0	0	0	0	0	0	0	0	0	0	1
4:45 PM	0	0	0	0	0	0	0	0	0	0	0	0	0
5:00 PM	0	0	0	0	0	0	0	0	0	1	0	0	1
5:15 PM	0	0	0	0	0	0	0	0	0	1	0	0	1
5:30 PM	0	0	0	0	1	0	0	0	0	1	0	0	2
5:45 PM	0	0	0	0	0	0	0	0	0	0	0	0	0
TOTAL VOLUMES :	NL	NT	NR	SL	ST	SR	EL	ET	ER	WL	WT	WR	TOTAL
APPROACH %'s :	2	0	0	0	2	0	0	0	0	4	0	1	9
	100.00%	0.00%	0.00%	0.00%	100.00%	0.00%	#DIV/0!	#DIV/0!	#DIV/0!	80.00%	0.00%	20.00%	
PEAK HR START TIME :	445 PM												TOTAL
PEAK HR VOL :	0	0	0	0	1	0	0	0	0	3	0	0	4
PEAK HR FACTOR :	0.000			0.250			0.000			0.750			0.969

UTURNS			
NB	SB	EB	WB

NB	SB	EB	WB
0	0	0	0

CONTROL : Signalized

Intersection Turning Movement

Prepared by:

National Data & Surveying Services

Project ID: 14-5572-004

Day: Thursday

City: Calabasas

TOTALS

Date: 9/11/2014

AM													
NS/EW Streets:	Las Virgenes Rd			Las Virgenes Rd			Agoura Rd			Agoura Rd			
	NORTHBOUND			SOUTHBOUND			EASTBOUND			WESTBOUND			
LANES:	NL	NT	NR	SL	ST	SR	EL	ET	ER	WL	WT	WR	TOTAL
7:00 AM	16	42	0	0	237	94	50	0	23	0	0	0	462
7:15 AM	12	119	0	0	291	95	53	0	24	0	0	0	594
7:30 AM	26	127	0	0	214	110	57	0	18	0	0	0	552
7:45 AM	17	110	0	0	233	155	44	0	29	0	0	0	588
8:00 AM	14	130	0	0	236	146	55	0	30	0	0	0	611
8:15 AM	27	168	0	0	305	162	49	0	53	0	0	0	764
8:30 AM	34	176	0	0	233	134	66	0	15	0	0	0	658
8:45 AM	17	99	0	0	169	131	52	0	11	0	0	0	479
TOTAL VOLUMES :	NL	NT	NR	SL	ST	SR	EL	ET	ER	WL	WT	WR	TOTAL
APPROACH %'s :	163	971	0	0	1918	1027	426	0	203	0	0	0	4708
	14.37%	85.63%	0.00%	0.00%	65.13%	34.87%	67.73%	0.00%	32.27%	#DIV/0!	#DIV/0!	#DIV/0!	
PEAK HR START TIME :	745 AM												TOTAL
PEAK HR VOL :	92	584	0	0	1007	597	214	0	127	0	0	0	2621
PEAK HR FACTOR :	0.805			0.859			0.836			0.000			0.858

UTURNS			
NB	SB	EB	WB
0	0	0	0

NB	SB	EB	WB
0	0	0	0

CONTROL : Signalized

Intersection Turning Movement

Prepared by:

National Data & Surveying Services

Project ID: 14-5572-004

Day: Thursday

City: Calabasas

TOTALS

Date: 9/11/2014

NS/EW Streets:	PM												TOTAL
	Las Virgenes Rd			Las Virgenes Rd			Agoura Rd			Agoura Rd			
	NORTHBOUND			SOUTHBOUND			EASTBOUND			WESTBOUND			
LANES:	NL	NT	NR	SL	ST	SR	EL	ET	ER	WL	WT	WR	
4:00 PM	20	207	0	0	126	55	155	0	27	0	0	0	590
4:15 PM	26	219	0	0	121	49	183	0	29	0	0	0	627
4:30 PM	24	167	0	1	115	49	161	0	26	0	0	0	543
4:45 PM	35	207	0	0	121	43	196	0	30	0	0	0	632
5:00 PM	23	186	0	0	138	69	196	0	23	0	0	0	635
5:15 PM	17	184	0	0	111	61	175	0	27	0	0	0	575
5:30 PM	15	173	0	0	111	55	163	0	24	0	0	0	541
5:45 PM	18	161	0	0	119	44	141	0	32	0	0	0	515

UTURNS			
NB	SB	EB	WB
0	0	0	0
0	0	0	0
1	0	0	0
0	0	0	0
0	0	0	0
0	0	0	0
0	0	0	0
0	0	0	0

TOTAL VOLUMES :	NL	NT	NR	SL	ST	SR	EL	ET	ER	WL	WT	WR	TOTAL
APPROACH %'s :	10.58%	89.42%	0.00%	0.07%	69.31%	30.62%	86.27%	0.00%	13.73%	#DIV/0!	#DIV/0!	#DIV/0!	4658

NB	SB	EB	WB
0	1	0	0

PEAK HR START TIME :	415 PM												TOTAL
PEAK HR VOL :	108	779	0	1	495	210	736	0	108	0	0	0	2437
PEAK HR FACTOR :	0.905			0.853			0.934			0.000			0.959

CONTROL : Signalized

ITM Peak Hour Summary

Prepared by:



National Data & Surveying Services

Las Virgenes Rd and Agoura Rd, Calabasas

Date: 9/11/2014
Day: Thursday

Project #: 14-5572-004
City: Calabasas

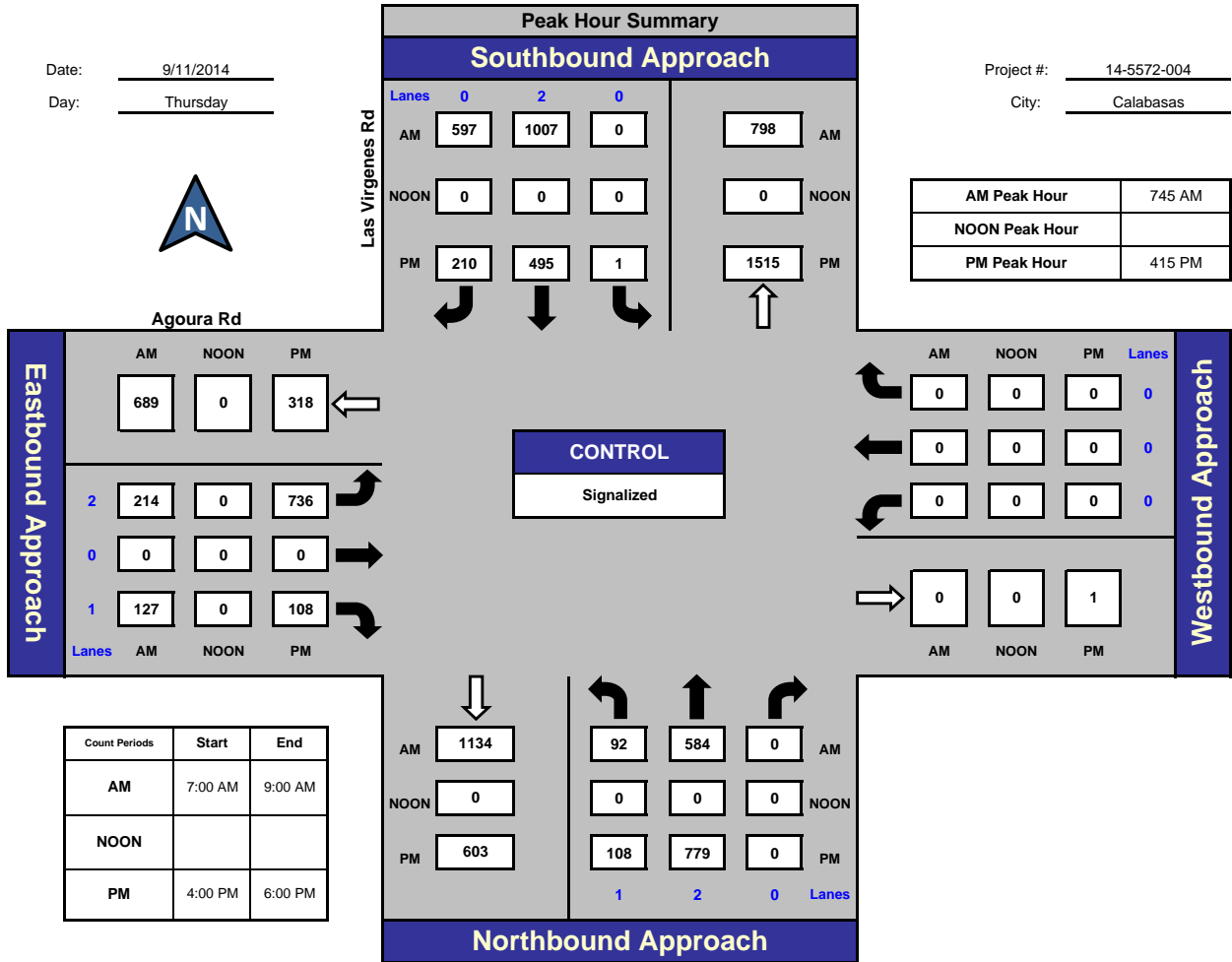

Total Ins & Outs

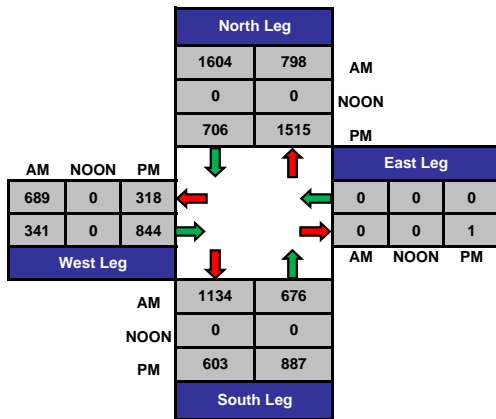

Total Volume Per Leg

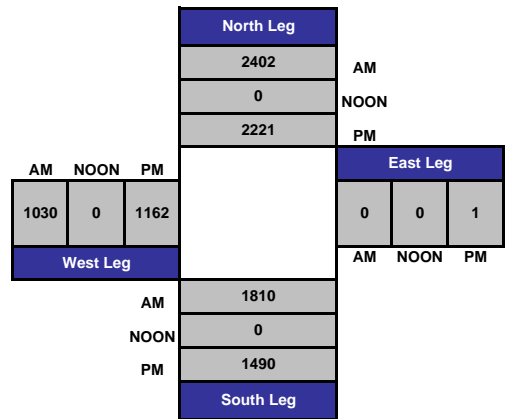

Intersection Turning Movement

Prepared by:

National Data & Surveying Services

Project ID: 14-5572-004

Day: Thursday

City: Calabasas

Cars

Date: 9/11/2014

AM

NS/EW Streets:	Las Virgenes Rd			Las Virgenes Rd			Agoura Rd			Agoura Rd			TOTAL
	NORTHBOUND			SOUTHBOUND			EASTBOUND			WESTBOUND			
LANES:	NL	NT	NR	SL	ST	SR	EL	ET	ER	WL	WT	WR	
	1	2	0	0	2	0	2	0	1	0	0	0	
7:00 AM	16	42	0	0	237	94	50	0	23	0	0	0	462
7:15 AM	12	119	0	0	291	95	52	0	24	0	0	0	593
7:30 AM	26	126	0	0	214	110	56	0	18	0	0	0	550
7:45 AM	17	108	0	0	233	155	44	0	29	0	0	0	586
8:00 AM	14	129	0	0	236	146	55	0	30	0	0	0	610
8:15 AM	27	168	0	0	305	162	48	0	53	0	0	0	763
8:30 AM	34	176	0	0	232	133	65	0	15	0	0	0	655
8:45 AM	17	96	0	0	169	131	52	0	11	0	0	0	476

UTURNS			
NB	SB	EB	WB

TOTAL VOLUMES :	NL	NT	NR	SL	ST	SR	EL	ET	ER	WL	WT	WR	TOTAL
APPROACH %'s :	163	964	0	0	1917	1026	422	0	203	0	0	0	4695
	14.46%	85.54%	0.00%	0.00%	65.14%	34.86%	67.52%	0.00%	32.48%	#DIV/0!	#DIV/0!	#DIV/0!	

NB	SB	EB	WB
0	0	0	0

PEAK HR START TIME :	745 AM												TOTAL
PEAK HR VOL :	92	581	0	0	1006	596	212	0	127	0	0	0	2614
PEAK HR FACTOR :	0.801			0.858			0.839			0.000			0.856

CONTROL : Signalized

Intersection Turning Movement

Prepared by:

National Data & Surveying Services

Project ID: 14-5572-004

Day: Thursday

City: Calabasas

Cars

Date: 9/11/2014

PM

NS/EW Streets:	Las Virgenes Rd			Las Virgenes Rd			Agoura Rd			Agoura Rd			TOTAL
	NORTHBOUND			SOUTHBOUND			EASTBOUND			WESTBOUND			
LANES:	NL	NT	NR	SL	ST	SR	EL	ET	ER	WL	WT	WR	
4:00 PM	20	207	0	0	125	55	155	0	27	0	0	0	589
4:15 PM	26	219	0	0	121	49	183	0	29	0	0	0	627
4:30 PM	24	165	0	1	115	49	161	0	26	0	0	0	541
4:45 PM	35	207	0	0	121	43	196	0	30	0	0	0	632
5:00 PM	23	184	0	0	138	68	196	0	23	0	0	0	632
5:15 PM	17	184	0	0	111	60	175	0	27	0	0	0	574
5:30 PM	15	173	0	0	111	54	163	0	24	0	0	0	540
5:45 PM	18	161	0	0	119	43	141	0	32	0	0	0	514

UTURNS			
NB	SB	EB	WB
0	0	0	0
0	0	0	0
1	0	0	0
0	0	0	0
0	0	0	0
0	0	0	0
0	0	0	0
0	0	0	0

TOTAL VOLUMES :	NL	NT	NR	SL	ST	SR	EL	ET	ER	WL	WT	WR	TOTAL
APPROACH %'s :	178	1500	0	1	961	421	1370	0	218	0	0	0	4649
	10.61%	89.39%	0.00%	0.07%	69.49%	30.44%	86.27%	0.00%	13.73%	#DIV/0!	#DIV/0!	#DIV/0!	

NB	SB	EB	WB
0	1	0	0

PEAK HR START TIME :	415 PM												TOTAL
PEAK HR VOL :	108	775	0	1	495	209	736	0	108	0	0	0	2432
PEAK HR FACTOR :	0.901			0.856			0.934			0.000			0.962

CONTROL : Signalized

Intersection Turning Movement

Prepared by:

National Data & Surveying Services

Project ID: 14-5572-004

Day: Thursday

City: Calabasas

3 Axle+ Trucks

Date: 9/11/2014

AM													
NS/EW Streets:	Las Virgenes Rd			Las Virgenes Rd			Agoura Rd			Agoura Rd			
	NORTHBOUND			SOUTHBOUND			EASTBOUND			WESTBOUND			
LANES:	NL	NT	NR	SL	ST	SR	EL	ET	ER	WL	WT	WR	TOTAL
7:00 AM	0	0	0	0	0	0	0	0	0	0	0	0	0
7:15 AM	0	0	0	0	0	0	1	0	0	0	0	0	1
7:30 AM	0	1	0	0	0	0	1	0	0	0	0	0	2
7:45 AM	0	2	0	0	0	0	0	0	0	0	0	0	2
8:00 AM	0	1	0	0	0	0	0	0	0	0	0	0	1
8:15 AM	0	0	0	0	0	0	1	0	0	0	0	0	1
8:30 AM	0	0	0	0	1	1	1	0	0	0	0	0	3
8:45 AM	0	3	0	0	0	0	0	0	0	0	0	0	3
TOTAL VOLUMES :	NL	NT	NR	SL	ST	SR	EL	ET	ER	WL	WT	WR	TOTAL
APPROACH %'s :	0	7	0	0	1	1	4	0	0	0	0	0	13
	0.00%	100.00%	0.00%	0.00%	50.00%	50.00%	100.00%	0.00%	0.00%	#DIV/0!	#DIV/0!	#DIV/0!	
PEAK HR START TIME :	745 AM												TOTAL
PEAK HR VOL :	0	3	0	0	1	1	2	0	0	0	0	0	7
PEAK HR FACTOR :	0.375			0.250			0.500			0.000			0.856

UTURNS			
NB	SB	EB	WB
0	0	0	0

NB	SB	EB	WB
0	0	0	0

CONTROL : Signalized

Intersection Turning Movement

Prepared by:

National Data & Surveying Services

Project ID: 14-5572-004

Day: Thursday

City: Calabasas

3 Axle+ Trucks

Date: 9/11/2014

PM

NS/EW Streets:	Las Virgenes Rd		Las Virgenes Rd			Agoura Rd			Agoura Rd			TOTAL	
	NORTHBOUND			SOUTHBOUND			EASTBOUND			WESTBOUND			
LANES:	NL	NT	NR	SL	ST	SR	EL	ET	ER	WL	WT	WR	
4:00 PM	0	0	0	0	1	0	0	0	0	0	0	0	1
4:15 PM	0	0	0	0	0	0	0	0	0	0	0	0	0
4:30 PM	0	2	0	0	0	0	0	0	0	0	0	0	2
4:45 PM	0	0	0	0	0	0	0	0	0	0	0	0	0
5:00 PM	0	2	0	0	0	1	0	0	0	0	0	0	3
5:15 PM	0	0	0	0	0	1	0	0	0	0	0	0	1
5:30 PM	0	0	0	0	0	1	0	0	0	0	0	0	1
5:45 PM	0	0	0	0	0	1	0	0	0	0	0	0	1
TOTAL VOLUMES :	NL	NT	NR	SL	ST	SR	EL	ET	ER	WL	WT	WR	TOTAL
APPROACH %'s :	0	4	0	0	1	4	0	0	0	0	0	0	9
	0.00%	100.00%	0.00%	0.00%	20.00%	80.00%	#DIV/0!	#DIV/0!	#DIV/0!	#DIV/0!	#DIV/0!	#DIV/0!	
PEAK HR START TIME :	4:15 PM												TOTAL
PEAK HR VOL :	0	4	0	0	0	1	0	0	0	0	0	0	5
PEAK HR FACTOR :	0.500			0.250			0.000			0.000			0.962

UTURNS			
NB	SB	EB	WB

NB	SB	EB	WB
0	0	0	0

CONTROL : Signalized

PREPARED BY NATIONAL DATA & SURVEYING SERVICES

PROJECT#: 14-5572-004
 N/S Street: Las Virgenes Rd
 E/W Street: Agoura Rd
 DATE: 9/11/2014
 CITY: Calabasas

DAY: Thursday

A M

PEDESTRIANS

T I M E	NORTH LEG		SOUTH LEG		EAST LEG		WEST LEG	
	EB	WB	EB	WB	NB	SB	NB	SB
7:00 AM	0	0	0	0	0	0	1	1
7:15 AM	0	0	0	0	0	0	0	0
7:30 AM	0	0	0	0	0	0	0	0
7:45 AM	0	0	0	0	0	0	1	1
8:00 AM	0	0	0	1	0	0	0	0
8:15 AM	0	0	1	1	0	0	2	2
8:30 AM	0	0	0	0	0	0	0	0
8:45 AM	0	1	0	0	0	0	0	0
TOTALS	0	1	1	2	0	0	4	4

BIKES

T I M E	NB			SB			EB			WB		
	NL	NT	NR	SL	ST	SR	EL	ET	ER	WL	WT	WR
7:00 AM	0	0	0	0	0	0	0	0	0	0	0	0
7:15 AM	0	0	0	0	0	0	1	0	0	0	0	0
7:30 AM	0	1	0	0	0	3	0	0	0	0	0	0
7:45 AM	0	0	0	0	0	0	1	0	0	0	0	0
8:00 AM	0	0	0	0	0	0	0	0	0	0	0	0
8:15 AM	0	0	0	0	0	0	0	0	0	0	0	0
8:30 AM	0	0	0	0	0	0	0	0	0	0	0	0
8:45 AM	0	0	0	0	0	0	2	0	0	0	0	0
TOTALS	0	1	0	0	0	3	4	0	0	0	0	0

P M

PEDESTRIANS

T I M E	NORTH LEG		SOUTH LEG		EAST LEG		WEST LEG	
	EB	WB	EB	WB	NB	SB	NB	SB
4:00 PM	0	0	0	0	0	0	0	1
4:15 PM	0	0	0	0	0	0	3	2
4:30 PM	0	0	0	0	0	0	1	1
4:45 PM	0	0	0	1	0	0	0	1
5:00 PM	0	0	0	0	0	0	2	0
5:15 PM	0	0	0	0	0	0	1	2
5:30 PM	0	0	0	0	0	0	2	1
5:45 PM	0	0	0	0	0	0	0	0
TOTALS	0	0	0	1	0	0	9	8

BIKES

T I M E	NB			SB			EB			WB		
	NL	NT	NR	SL	ST	SR	EL	ET	ER	WL	WT	WR
4:00 PM	0	1	0	0	0	0	0	0	2	0	0	0
4:15 PM	0	0	0	0	0	0	1	0	0	0	0	0
4:30 PM	0	0	0	0	0	1	1	0	0	0	0	0
4:45 PM	0	1	0	0	0	0	0	0	0	0	0	0
5:00 PM	0	0	0	0	0	0	0	0	0	0	0	0
5:15 PM	0	0	0	0	0	0	0	0	0	0	0	0
5:30 PM	0	0	0	0	1	1	1	0	0	0	0	0
5:45 PM	0	0	0	0	0	0	1	0	0	0	0	0
TOTALS	0	2	0	0	1	2	4	0	2	0	0	0

Intersection Turning Movement

Prepared by:

National Data & Surveying Services

Project ID: 14-5572-005

Day: Thursday

City: Calabasas

TOTALS

Date: 9/11/2014

NS/EW Streets:	AM												TOTAL
	Lost Hills Rd			Lost Hills Rd			Agoura Rd			Agoura Rd			
	NORTHBOUND			SOUTHBOUND			EASTBOUND			WESTBOUND			
LANES:	NL	NT	NR	SL	ST	SR	EL	ET	ER	WL	WT	WR	
7:00 AM	3	59	10	35	244	30	4	18	8	4	14	6	435
7:15 AM	4	90	15	51	183	26	5	18	6	12	26	22	458
7:30 AM	3	114	22	58	171	34	5	20	3	12	20	10	472
7:45 AM	3	119	19	61	201	59	4	11	9	9	28	13	536
8:00 AM	8	104	9	71	171	53	11	30	4	17	30	19	527
8:15 AM	5	120	12	85	200	65	6	26	5	17	24	22	587
8:30 AM	9	108	20	98	197	57	9	33	5	11	35	22	604
8:45 AM	6	96	9	74	167	52	8	24	8	5	28	19	496
TOTAL VOLUMES :	NL	NT	NR	SL	ST	SR	EL	ET	ER	WL	WT	WR	TOTAL
APPROACH %'s :	41	810	116	533	1534	376	52	180	48	87	205	133	4115
	4.24%	83.76%	12.00%	21.82%	62.79%	15.39%	18.57%	64.29%	17.14%	20.47%	48.24%	31.29%	
PEAK HR START TIME :	745 AM												TOTAL
PEAK HR VOL :	25	451	60	315	769	234	30	100	23	54	117	76	2254
PEAK HR FACTOR :	0.950			0.936			0.814			0.908			0.933

UTURNS			
NB	SB	EB	WB

NB	SB	EB	WB
0	0	0	0

CONTROL : Signalized

Intersection Turning Movement

Prepared by:

National Data & Surveying Services

Project ID: 14-5572-005

Day: Thursday

City: Calabasas

TOTALS

Date: 9/11/2014

PM

NS/EW Streets:	Lost Hills Rd			Lost Hills Rd			Agoura Rd			Agoura Rd			TOTAL
	NORTHBOUND			SOUTHBOUND			EASTBOUND			WESTBOUND			
LANES:	NL	NT	NR	SL	ST	SR	EL	ET	ER	WL	WT	WR	
	1	2	0	2	2	0	1	3	0	1	2	1	
4:00 PM	13	126	6	58	84	13	46	53	17	12	24	50	502
4:15 PM	11	95	12	69	86	11	22	51	13	14	26	45	455
4:30 PM	16	118	7	74	101	8	35	44	7	17	44	61	532
4:45 PM	14	129	21	65	79	8	30	46	14	20	36	52	514
5:00 PM	19	127	14	29	91	9	55	68	12	9	47	59	539
5:15 PM	23	148	14	79	96	11	36	59	22	15	47	52	602
5:30 PM	14	129	10	51	134	9	38	65	9	17	60	59	595
5:45 PM	15	119	14	38	88	6	28	41	13	18	34	40	454

UTURNS			
NB	SB	EB	WB

TOTAL VOLUMES :	NL	NT	NR	SL	ST	SR	EL	ET	ER	WL	WT	WR	TOTAL
APPROACH %'s :	10.30%	81.63%	8.07%	35.70%	58.52%	5.78%	35.19%	51.82%	12.99%	14.22%	37.06%	48.72%	4193

NB	SB	EB	WB
0	0	0	0

PEAK HR START TIME :	4:45 PM												TOTAL
PEAK HR VOL :	70	533	59	224	400	37	159	238	57	61	190	222	2250
PEAK HR FACTOR :	0.895			0.852			0.841			0.869			0.934

CONTROL : Signalized

ITM Peak Hour Summary

Prepared by:



National Data & Surveying Services

Lost Hills Rd and Agoura Rd, Calabasas

Date: 9/11/2014

Day: Thursday

Project #: 14-5572-005

City: Calabasas

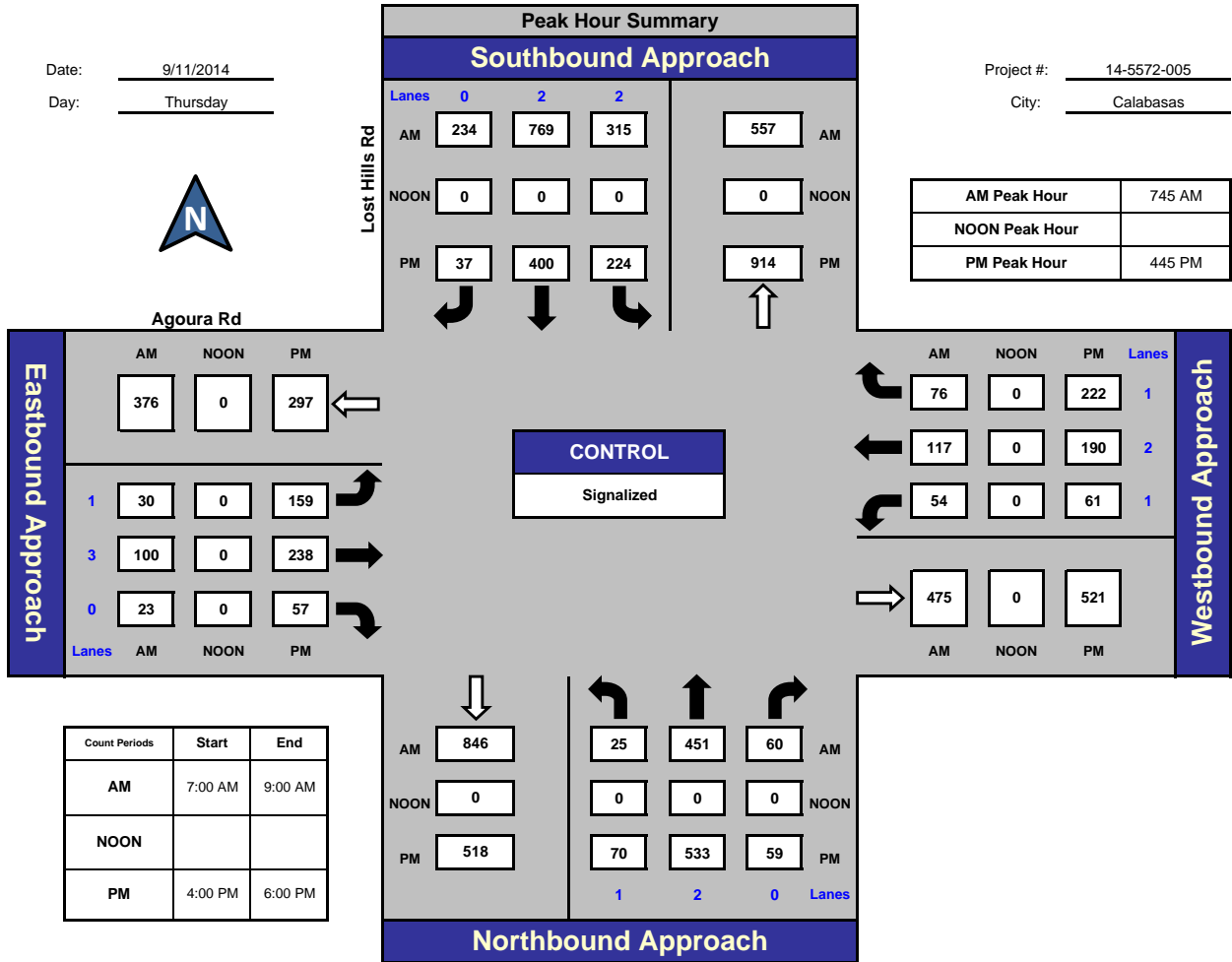

Total Ins & Outs

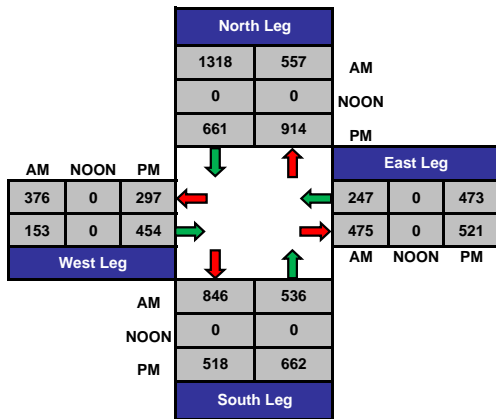

Total Volume Per Leg

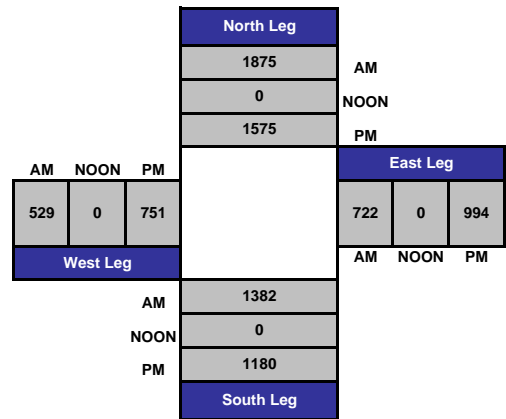

Intersection Turning Movement

Prepared by:

National Data & Surveying Services

Project ID: 14-5572-005

Day: Thursday

City: Calabasas

Cars

Date: 9/11/2014

AM

NS/EW Streets:	Lost Hills Rd			Lost Hills Rd			Agoura Rd			Agoura Rd			TOTAL
	NORTHBOUND			SOUTHBOUND			EASTBOUND			WESTBOUND			
LANES:	NL	NT	NR	SL	ST	SR	EL	ET	ER	WL	WT	WR	
7:00 AM	3	59	10	35	238	30	4	18	8	4	14	6	429
7:15 AM	4	90	15	51	182	26	5	18	5	12	26	21	455
7:30 AM	3	113	22	58	171	34	5	19	2	12	20	10	469
7:45 AM	3	119	19	61	199	59	3	11	9	9	28	13	533
8:00 AM	8	104	9	71	170	53	10	30	4	17	30	19	525
8:15 AM	5	120	12	84	197	65	6	26	5	17	24	21	582
8:30 AM	9	108	20	97	197	57	9	33	5	11	35	22	603
8:45 AM	6	96	9	74	166	52	7	24	8	5	28	18	493
TOTAL VOLUMES :	NL	NT	NR	SL	ST	SR	EL	ET	ER	WL	WT	WR	TOTAL
APPROACH %'s :	41	809	116	531	1520	376	49	179	46	87	205	130	4089
	4.24%	83.75%	12.01%	21.88%	62.63%	15.49%	17.88%	65.33%	16.79%	20.62%	48.58%	30.81%	
PEAK HR START TIME :	745 AM												TOTAL
PEAK HR VOL :	25	451	60	313	763	234	28	100	23	54	117	75	2243
PEAK HR FACTOR :	0.950			0.933			0.803			0.904			0.930

UTURNS			
NB	SB	EB	WB
0	0	0	0

NB	SB	EB	WB
0	0	0	0

CONTROL : Signalized

Intersection Turning Movement

Prepared by:

National Data & Surveying Services

Project ID: 14-5572-005

Day: Thursday

City: Calabasas

Cars

Date: 9/11/2014

PM

NS/EW Streets:	Lost Hills Rd			Lost Hills Rd			Agoura Rd			Agoura Rd			TOTAL
	NORTHBOUND			SOUTHBOUND			EASTBOUND			WESTBOUND			
LANES:	NL	NT	NR	SL	ST	SR	EL	ET	ER	WL	WT	WR	
	1	2	0	2	2	0	1	3	0	1	2	1	
4:00 PM	13	125	6	58	84	13	46	53	17	12	24	50	501
4:15 PM	11	95	12	69	86	11	22	51	13	14	26	45	455
4:30 PM	16	118	7	74	101	8	35	44	7	17	44	61	532
4:45 PM	14	129	21	65	79	8	30	45	14	20	36	52	513
5:00 PM	19	127	14	29	91	9	55	68	12	9	47	59	539
5:15 PM	23	147	14	79	96	11	36	59	22	15	47	51	600
5:30 PM	14	129	10	51	134	9	38	65	9	17	60	58	594
5:45 PM	15	119	14	38	88	6	28	41	13	18	34	40	454

UTURNS			
NB	SB	EB	WB

	NL	NT	NR	SL	ST	SR	EL	ET	ER	WL	WT	WR	TOTAL
TOTAL VOLUMES :	125	989	98	463	759	75	290	426	107	122	318	416	4188
APPROACH %'s :	10.31%	81.60%	8.09%	35.70%	58.52%	5.78%	35.24%	51.76%	13.00%	14.25%	37.15%	48.60%	

NB	0	SB	0	EB	0	WB	0
----	---	----	---	----	---	----	---

PEAK HR START TIME :	445 PM												TOTAL
PEAK HR VOL :	70	532	59	224	400	37	159	237	57	61	190	220	2246
PEAK HR FACTOR :	0.898			0.852			0.839			0.872			0.936

CONTROL : Signalized

Intersection Turning Movement

Prepared by:

National Data & Surveying Services

Project ID: 14-5572-005

Day: Thursday

City: Calabasas

3 Axle+ Trucks

Date: 9/11/2014

AM														
NS/EW Streets:	Lost Hills Rd			Lost Hills Rd			Agoura Rd			Agoura Rd				
	NORTHBOUND			SOUTHBOUND			EASTBOUND			WESTBOUND				
LANES:	NL	NT	NR	SL	ST	SR	EL	ET	ER	WL	WT	WR	TOTAL	
7:00 AM	0	0	0	0	6	0	0	0	0	0	0	0	6	
7:15 AM	0	0	0	0	1	0	0	0	1	0	0	1	3	
7:30 AM	0	1	0	0	0	0	0	1	1	0	0	0	3	
7:45 AM	0	0	0	0	2	0	1	0	0	0	0	0	3	
8:00 AM	0	0	0	0	1	0	1	0	0	0	0	0	2	
8:15 AM	0	0	0	1	3	0	0	0	0	0	0	1	5	
8:30 AM	0	0	0	1	0	0	0	0	0	0	0	0	1	
8:45 AM	0	0	0	0	1	0	1	0	0	0	0	1	3	
TOTAL VOLUMES :	NL	NT	NR	SL	ST	SR	EL	ET	ER	WL	WT	WR	TOTAL	
APPROACH %'s :	0	1	0	2	14	0	3	1	2	0	0	3	26	
	0.00%	100.00%	0.00%	12.50%	87.50%	0.00%	50.00%	16.67%	33.33%	0.00%	0.00%	100.00%		
PEAK HR START TIME :	745 AM												TOTAL	
PEAK HR VOL :	0			0			0			0			1	11
PEAK HR FACTOR :	0.000			0.500			0.500			0.250			0.930	

UTURNS			
NB	SB	EB	WB

NB	SB	EB	WB
0	0	0	0

CONTROL : Signalized

Intersection Turning Movement

Prepared by:

National Data & Surveying Services

Project ID: 14-5572-005

Day: Thursday

City: Calabasas

3 Axle+ Trucks

Date: 9/11/2014

PM													
NS/EW Streets:	Lost Hills Rd			Lost Hills Rd			Agoura Rd			Agoura Rd			
	NORTHBOUND			SOUTHBOUND			EASTBOUND			WESTBOUND			
LANES:	NL	NT	NR	SL	ST	SR	EL	ET	ER	WL	WT	WR	TOTAL
4:00 PM	0	1	0	0	0	0	0	0	0	0	0	0	1
4:15 PM	0	0	0	0	0	0	0	0	0	0	0	0	0
4:30 PM	0	0	0	0	0	0	0	0	0	0	0	0	0
4:45 PM	0	0	0	0	0	0	0	1	0	0	0	0	1
5:00 PM	0	0	0	0	0	0	0	0	0	0	0	0	0
5:15 PM	0	1	0	0	0	0	0	0	0	0	0	1	2
5:30 PM	0	0	0	0	0	0	0	0	0	0	0	1	1
5:45 PM	0	0	0	0	0	0	0	0	0	0	0	0	0
TOTAL VOLUMES :	NL	NT	NR	SL	ST	SR	EL	ET	ER	WL	WT	WR	TOTAL
APPROACH %'s :	0	2	0	0	0	0	0	1	0	0	0	2	5
	0.00%	100.00%	0.00%	#DIV/0!	#DIV/0!	#DIV/0!	0.00%	100.00%	0.00%	0.00%	0.00%	100.00%	
PEAK HR START TIME :	445 PM												TOTAL
PEAK HR VOL :	0	1	0	0	0	0	0	1	0	0	0	2	4
PEAK HR FACTOR :	0.250			0.000			0.250			0.500			0.936

UTURNS			
NB	SB	EB	WB
0	0	0	0

NB	SB	EB	WB
0	0	0	0

CONTROL : Signalized

PREPARED BY NATIONAL DATA & SURVEYING SERVICES

PROJECT#: 14-5572-005
 N/S Street: Lost Hills Rd
 E/W Street: Agoura Rd
 DATE: 9/11/2014
 CITY: Calabasas

DAY: Thursday

A M

PEDESTRIANS

T I M E	NORTH LEG		SOUTH LEG		EAST LEG		WEST LEG	
	EB	WB	EB	WB	NB	SB	NB	SB
7:00 AM	0	0	0	0	0	0	0	1
7:15 AM	0	0	0	0	0	0	0	0
7:30 AM	0	0	0	1	1	0	1	0
7:45 AM	0	0	0	0	0	0	0	0
8:00 AM	0	0	0	0	0	0	0	0
8:15 AM	0	0	0	0	0	0	1	0
8:30 AM	0	0	0	1	0	0	0	0
8:45 AM	0	1	0	0	0	0	0	0
TOTALS	0	1	0	2	1	0	2	1

BIKES

T I M E	NB			SB			EB			WB		
	NL	NT	NR	SL	ST	SR	EL	ET	ER	WL	WT	WR
7:00 AM	0	0	0	0	0	0	0	0	0	0	0	0
7:15 AM	0	0	0	0	0	0	0	1	0	0	0	1
7:30 AM	0	0	0	0	0	0	0	1	0	0	0	0
7:45 AM	0	0	0	0	0	0	0	1	0	0	4	0
8:00 AM	0	0	0	0	0	0	0	0	0	0	1	0
8:15 AM	0	0	0	0	0	0	0	1	0	0	2	0
8:30 AM	0	0	0	0	0	0	0	1	1	0	0	0
8:45 AM	0	0	0	0	0	0	0	3	0	0	0	0
TOTALS	0	0	0	0	0	0	0	8	1	0	7	1

P M

PEDESTRIANS

T I M E	NORTH LEG		SOUTH LEG		EAST LEG		WEST LEG	
	EB	WB	EB	WB	NB	SB	NB	SB
4:00 PM	0	2	2	0	1	1	0	0
4:15 PM	0	0	0	0	0	0	0	0
4:30 PM	0	0	0	0	0	0	1	0
4:45 PM	0	0	0	0	0	0	0	1
5:00 PM	0	0	0	0	0	0	0	1
5:15 PM	0	0	0	0	0	0	1	0
5:30 PM	0	0	0	0	0	0	0	0
5:45 PM	0	0	0	0	0	0	0	0
TOTALS	0	2	2	0	1	1	2	2

BIKES

T I M E	NB			SB			EB			WB		
	NL	NT	NR	SL	ST	SR	EL	ET	ER	WL	WT	WR
4:00 PM	0	0	0	0	0	0	0	0	0	0	0	0
4:15 PM	0	0	0	0	0	0	0	1	0	0	2	0
4:30 PM	0	0	0	0	0	0	0	0	0	0	0	0
4:45 PM	0	0	0	0	0	0	0	3	0	0	2	0
5:00 PM	0	0	0	0	0	0	0	0	0	0	0	0
5:15 PM	0	0	0	0	0	0	0	0	0	0	1	0
5:30 PM	0	0	0	0	0	0	0	0	0	0	1	0
5:45 PM	0	0	0	0	0	0	0	1	0	1	0	0
TOTALS	0	0	0	0	0	0	0	5	0	1	6	0

Intersection Turning Movement

Prepared by:

National Data & Surveying Services

Project ID: 14-5572-103

Day: Thursday

City: Calabasas

TOTALS

Date: 9/11/2014

AM

NS/EW Streets:	Las Virgenes Rd			Las Virgenes Rd			US-101 NB Ramps			US-101 NB Ramps			TOTAL
	NORTHBOUND			SOUTHBOUND			EASTBOUND			WESTBOUND			
LANES:	NL	NT	NR	SL	ST	SR	EL	ET	ER	WL	WT	WR	
	0	2	1	1	2	1	0.5	0.5	1	0	1	0	
7:00 AM	0	0	32	0	0	0	0	0	0	0	0	0	32
7:15 AM	0	0	66	0	0	0	0	0	0	0	0	0	66
7:30 AM	0	0	143	0	0	0	0	0	0	0	0	0	143
7:45 AM	0	0	58	0	0	0	0	0	0	0	0	0	58
8:00 AM	0	0	74	0	0	0	0	0	0	0	0	0	74
8:15 AM	0	0	67	0	0	0	0	0	0	0	0	0	67
8:30 AM	0	0	80	0	0	0	0	0	0	0	0	0	80
8:45 AM	0	0	52	0	0	0	0	0	0	0	0	0	52
TOTAL VOLUMES :	NL	NT	NR	SL	ST	SR	EL	ET	ER	WL	WT	WR	TOTAL
APPROACH %'s :	0	0	572	0	0	0	0	0	0	0	0	0	572
	0.00%	0.00%	100.00%	#DIV/0!	#DIV/0!	#DIV/0!	#DIV/0!	#DIV/0!	#DIV/0!	#DIV/0!	#DIV/0!	#DIV/0!	
PEAK HR START TIME :	730 AM												TOTAL
PEAK HR VOL :	0	0	342	0	0	0	0	0	0	0	0	0	342
PEAK HR FACTOR :	0.598			0.000			0.000			0.000			0.598

UTURNS			
NB	SB	EB	WB
0	0	0	0

NB	SB	EB	WB
0	0	0	0

CONTROL : Signalized

Intersection Turning Movement

Prepared by:

National Data & Surveying Services

Project ID: 14-5572-103

Day: Thursday

City: Calabasas

TOTALS

Date: 9/11/2014

PM

NS/EW Streets:	Las Virgenes Rd		Las Virgenes Rd			US-101 NB Ramps			US-101 NB Ramps			TOTAL	
	NORTHBOUND			SOUTHBOUND			EASTBOUND			WESTBOUND			
LANES:	NL	NT	NR	SL	ST	SR	EL	ET	ER	WL	WT	WR	
	0	2	1	1	2	1	0.5	0.5	1	0	1	0	
4:00 PM	0	0	146	0	0	0	0	0	0	0	0	0	146
4:15 PM	0	0	177	0	0	0	0	0	0	0	0	0	177
4:30 PM	0	0	164	0	0	0	0	0	0	0	0	0	164
4:45 PM	0	0	167	0	0	0	0	0	0	0	0	0	167
5:00 PM	0	0	180	0	0	0	0	0	0	0	0	0	180
5:15 PM	0	0	167	0	0	0	0	0	0	0	0	0	167
5:30 PM	0	0	161	0	0	0	0	0	0	0	0	0	161
5:45 PM	0	0	134	0	0	0	0	0	0	0	0	0	134
TOTAL VOLUMES :	NL	NT	NR	SL	ST	SR	EL	ET	ER	WL	WT	WR	TOTAL
APPROACH %'s :	0	0	1296	0	0	0	0	0	0	0	0	0	1296
	0.00%	0.00%	100.00%	#DIV/0!	#DIV/0!	#DIV/0!	#DIV/0!	#DIV/0!	#DIV/0!	#DIV/0!	#DIV/0!	#DIV/0!	
PEAK HR START TIME :	4:15 PM												TOTAL
PEAK HR VOL :	0	0	688	0	0	0	0	0	0	0	0	0	688
PEAK HR FACTOR :	0.956		0.000			0.000			0.000			0.956	

UTURNS			
NB	SB	EB	WB
0	0	0	0

NB	SB	EB	WB
0	0	0	0

CONTROL : Signalized

ITM Peak Hour Summary

Prepared by:



National Data & Surveying Services

Las Virgenes Rd and US-101 NB Ramps, Calabasas

Date: 9/11/2014

Day: Thursday

Project #: 14-5572-103

City: Calabasas

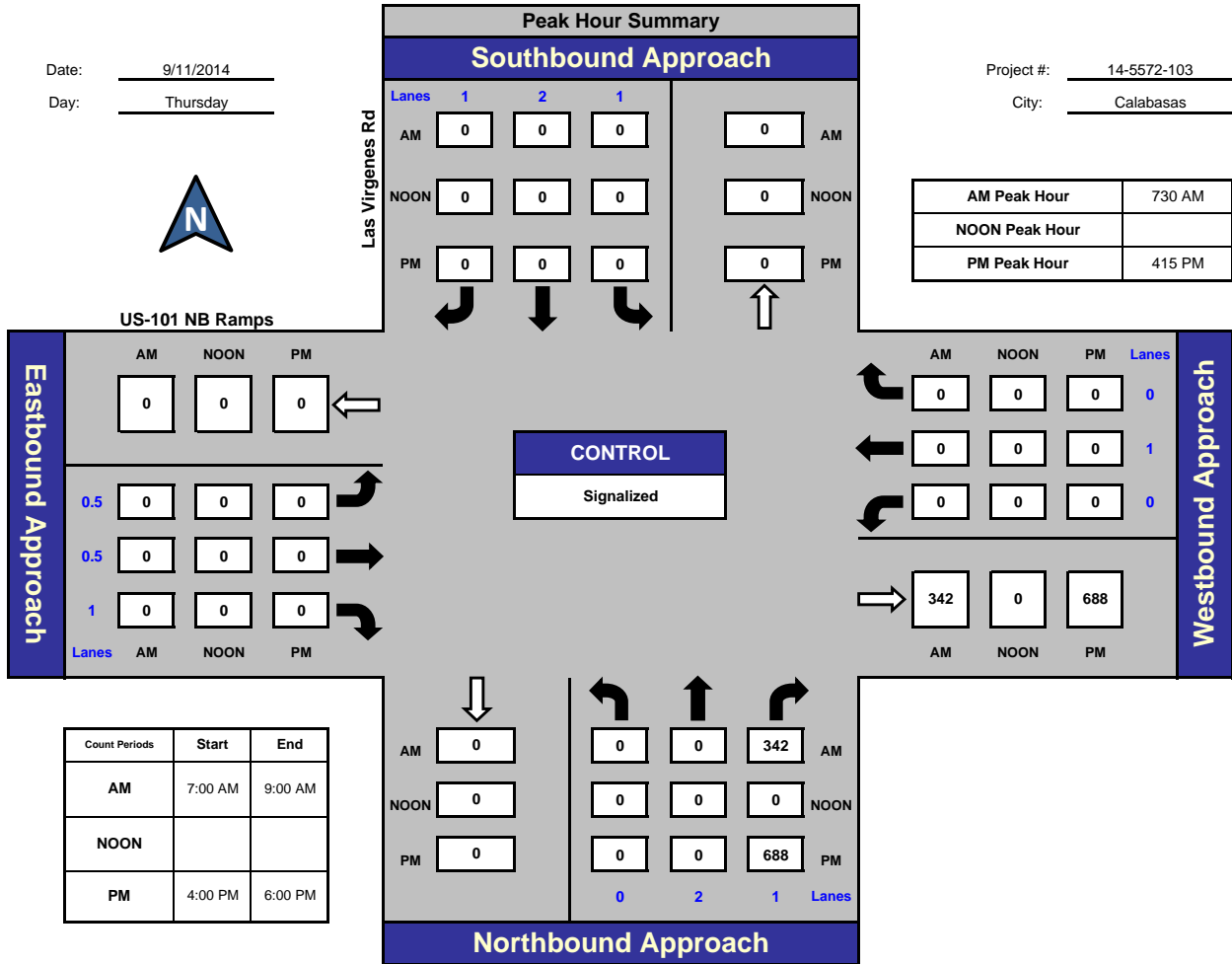

Total Ins & Outs

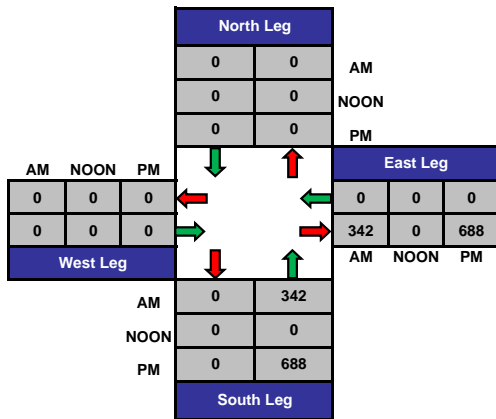

Total Volume Per Leg

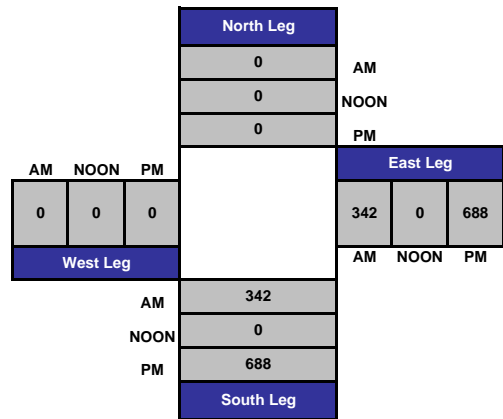

Intersection Turning Movement

Prepared by:

National Data & Surveying Services

Project ID: 14-5572-103

Day: Thursday

City: Calabasas

Cars

Date: 9/11/2014

AM

NS/EW Streets:	Las Virgenes Rd			Las Virgenes Rd			US-101 NB Ramps			US-101 NB Ramps			TOTAL
	NORTHBOUND			SOUTHBOUND			EASTBOUND			WESTBOUND			
LANES:	NL	NT	NR	SL	ST	SR	EL	ET	ER	WL	WT	WR	
	0	2	1	1	2	1	0.5	0.5	1	0	1	0	
7:00 AM	0	0	32	0	0	0	0	0	0	0	0	0	32
7:15 AM	0	0	66	0	0	0	0	0	0	0	0	0	66
7:30 AM	0	0	143	0	0	0	0	0	0	0	0	0	143
7:45 AM	0	0	58	0	0	0	0	0	0	0	0	0	58
8:00 AM	0	0	72	0	0	0	0	0	0	0	0	0	72
8:15 AM	0	0	66	0	0	0	0	0	0	0	0	0	66
8:30 AM	0	0	80	0	0	0	0	0	0	0	0	0	80
8:45 AM	0	0	51	0	0	0	0	0	0	0	0	0	51
TOTAL VOLUMES :	NL	NT	NR	SL	ST	SR	EL	ET	ER	WL	WT	WR	TOTAL
APPROACH %'s :	0	0	568	0	0	0	0	0	0	0	0	0	568
	0.00%	0.00%	100.00%	#DIV/0!	#DIV/0!	#DIV/0!	#DIV/0!	#DIV/0!	#DIV/0!	#DIV/0!	#DIV/0!	#DIV/0!	
PEAK HR START TIME :	730 AM												TOTAL
PEAK HR VOL :	0	0	339	0	0	0	0	0	0	0	0	0	339
PEAK HR FACTOR :	0.593			0.000			0.000			0.000			0.593

UTURNS			
NB	SB	EB	WB
0	0	0	0

NB	SB	EB	WB
0	0	0	0

CONTROL : Signalized

Intersection Turning Movement

Prepared by:

National Data & Surveying Services

Project ID: 14-5572-103

Day: Thursday

City: Calabasas

Cars

Date: 9/11/2014

PM

NS/EW Streets:	Las Virgenes Rd			Las Virgenes Rd			US-101 NB Ramps			US-101 NB Ramps			TOTAL
	NORTHBOUND			SOUTHBOUND			EASTBOUND			WESTBOUND			
LANES:	NL	NT	NR	SL	ST	SR	EL	ET	ER	WL	WT	WR	
	0	2	1	1	2	1	0.5	0.5	1	0	1	0	
4:00 PM	0	0	146	0	0	0	0	0	0	0	0	0	146
4:15 PM	0	0	177	0	0	0	0	0	0	0	0	0	177
4:30 PM	0	0	164	0	0	0	0	0	0	0	0	0	164
4:45 PM	0	0	166	0	0	0	0	0	0	0	0	0	166
5:00 PM	0	0	178	0	0	0	0	0	0	0	0	0	178
5:15 PM	0	0	167	0	0	0	0	0	0	0	0	0	167
5:30 PM	0	0	161	0	0	0	0	0	0	0	0	0	161
5:45 PM	0	0	134	0	0	0	0	0	0	0	0	0	134
TOTAL VOLUMES :	NL	NT	NR	SL	ST	SR	EL	ET	ER	WL	WT	WR	TOTAL
APPROACH %'s :	0	0	1293	0	0	0	0	0	0	0	0	0	1293
	0.00%	0.00%	100.00%	#DIV/0!	#DIV/0!	#DIV/0!	#DIV/0!	#DIV/0!	#DIV/0!	#DIV/0!	#DIV/0!	#DIV/0!	
PEAK HR START TIME :	4:15 PM												TOTAL
PEAK HR VOL :	0	0	685	0	0	0	0	0	0	0	0	0	685
PEAK HR FACTOR :	0.962		0.000			0.000			0.000			0.962	

UTURNS			
NB	SB	EB	WB
0	0	0	0

NB	SB	EB	WB
0	0	0	0

CONTROL : Signalized

Intersection Turning Movement

Prepared by:

National Data & Surveying Services

Project ID: 14-5572-103

Day: Thursday

City: Calabasas

3 Axle+ Trucks

Date: 9/11/2014

AM

NS/EW Streets:	Las Virgenes Rd			Las Virgenes Rd			US-101 NB Ramps			US-101 NB Ramps			TOTAL
	NORTHBOUND			SOUTHBOUND			EASTBOUND			WESTBOUND			
LANES:	NL	NT	NR	SL	ST	SR	EL	ET	ER	WL	WT	WR	
	0	2	1	1	2	1	0.5	0.5	1	0	1	0	
7:00 AM	0	0	0	0	0	0	0	0	0	0	0	0	0
7:15 AM	0	0	0	0	0	0	0	0	0	0	0	0	0
7:30 AM	0	0	0	0	0	0	0	0	0	0	0	0	0
7:45 AM	0	0	0	0	0	0	0	0	0	0	0	0	0
8:00 AM	0	0	2	0	0	0	0	0	0	0	0	0	2
8:15 AM	0	0	1	0	0	0	0	0	0	0	0	0	1
8:30 AM	0	0	0	0	0	0	0	0	0	0	0	0	0
8:45 AM	0	0	1	0	0	0	0	0	0	0	0	0	1
TOTAL VOLUMES :	NL	NT	NR	SL	ST	SR	EL	ET	ER	WL	WT	WR	TOTAL
APPROACH %'s :	0	0	4	0	0	0	0	0	0	0	0	0	4
	0.00%	0.00%	100.00%	#DIV/0!	#DIV/0!	#DIV/0!	#DIV/0!	#DIV/0!	#DIV/0!	#DIV/0!	#DIV/0!	#DIV/0!	
PEAK HR START TIME :	730 AM												TOTAL
PEAK HR VOL :	0	0	3	0	0	0	0	0	0	0	0	0	3
PEAK HR FACTOR :	0.375			0.000			0.000			0.000			0.593

UTURNS			
NB	SB	EB	WB
0	0	0	0

NB	SB	EB	WB
0	0	0	0

CONTROL : Signalized

Intersection Turning Movement

Prepared by:

National Data & Surveying Services

Project ID: 14-5572-103

Day: Thursday

City: Calabasas

3 Axle+ Trucks

Date: 9/11/2014

PM

NS/EW Streets:	Las Virgenes Rd		Las Virgenes Rd			US-101 NB Ramps			US-101 NB Ramps			TOTAL	
	NORTHBOUND			SOUTHBOUND			EASTBOUND			WESTBOUND			
LANES:	NL	NT	NR	SL	ST	SR	EL	ET	ER	WL	WT	WR	
	0	2	1	1	2	1	0.5	0.5	1	0	1	0	
4:00 PM	0	0	0	0	0	0	0	0	0	0	0	0	0
4:15 PM	0	0	0	0	0	0	0	0	0	0	0	0	0
4:30 PM	0	0	0	0	0	0	0	0	0	0	0	0	0
4:45 PM	0	0	1	0	0	0	0	0	0	0	0	0	1
5:00 PM	0	0	2	0	0	0	0	0	0	0	0	0	2
5:15 PM	0	0	0	0	0	0	0	0	0	0	0	0	0
5:30 PM	0	0	0	0	0	0	0	0	0	0	0	0	0
5:45 PM	0	0	0	0	0	0	0	0	0	0	0	0	0
TOTAL VOLUMES :	NL	NT	NR	SL	ST	SR	EL	ET	ER	WL	WT	WR	TOTAL
APPROACH %'s :	0	0	3	0	0	0	0	0	0	0	0	0	3
	0.00%	0.00%	100.00%	#DIV/0!	#DIV/0!	#DIV/0!	#DIV/0!	#DIV/0!	#DIV/0!	#DIV/0!	#DIV/0!	#DIV/0!	
PEAK HR START TIME :	4:15 PM												TOTAL
PEAK HR VOL :	0	0	3	0	0	0	0	0	0	0	0	0	3
PEAK HR FACTOR :	0.375			0.000			0.000			0.000			0.962

UTURNS			
NB	SB	EB	WB
0	0	0	0

NB	SB	EB	WB
0	0	0	0

CONTROL : Signalized

APPENDIX E

RELATED PROJECT TRIP GENERATION

RELATED PROJECT LIST
 RONDEL OASIS HOTEL - CALABASAS

#	ADDRESS	SIZE	PROJECT & LAND USE	STATUS	Daily Traffic	AM Peak Hour			PM Peak Hours		
						In	Out	Total	In	Out	Total
1	4240 Las Virgenes Rd	78 units	<u>Paxton Calabasas</u> Townhomes	Application Process	453	6	28	34	27	14	41
2	4790 Las Virgenes Rd	138 units 8 units 120 room	<u>Canyon Oaks</u> Single Family Homes Affordable Condominiums Hotel	Feasability Stage	1314 46 <u>980</u>	26 1 <u>38</u>	78 3 <u>26</u>	104 4 <u>64</u>	87 3 <u>37</u>	51 1 <u>35</u>	138 4 <u>72</u>
				SUM	2340	65	107	172	127	87	214
3	NW Corner Las Virgenes & Thousand Oaks Bl	25,820 sf 35,074 sf	<u>Commercial Center</u> Retail Office	Approved by LA Co.	1103 <u>387</u>	15 <u>48</u>	10 <u>7</u>	25 <u>55</u>	46 <u>9</u>	50 <u>43</u>	96 <u>52</u>
				SUM	1490	63	17	80	55	93	148
4	26901 Malibu Hills Rd	18,628 sf	<u>Cheesecake Factory</u> Quality Restaurant	Construction	1676	8	7	15	93	46	140
5	26705 Malibu Hills Rd	60 units	<u>Horizons Senior Center</u> Senior Condominiums	Final Construction	206	4	8	12	8	7	15
6	5300 Lost Hills Rd	600 tons/day 1,500 tons/day	Calabasas Landfill Expansion LA Co MND Current Solid Waste Previous Solid Waste Expand for Contract from both inside & outside Watershed								
			Net Increase from 2007 baseline		89	9	9	18	9	9	18
			Estimate conservative 20% during peaks with 50-50 split								

APPENDIX F

BICYCLE PLAN MAPS

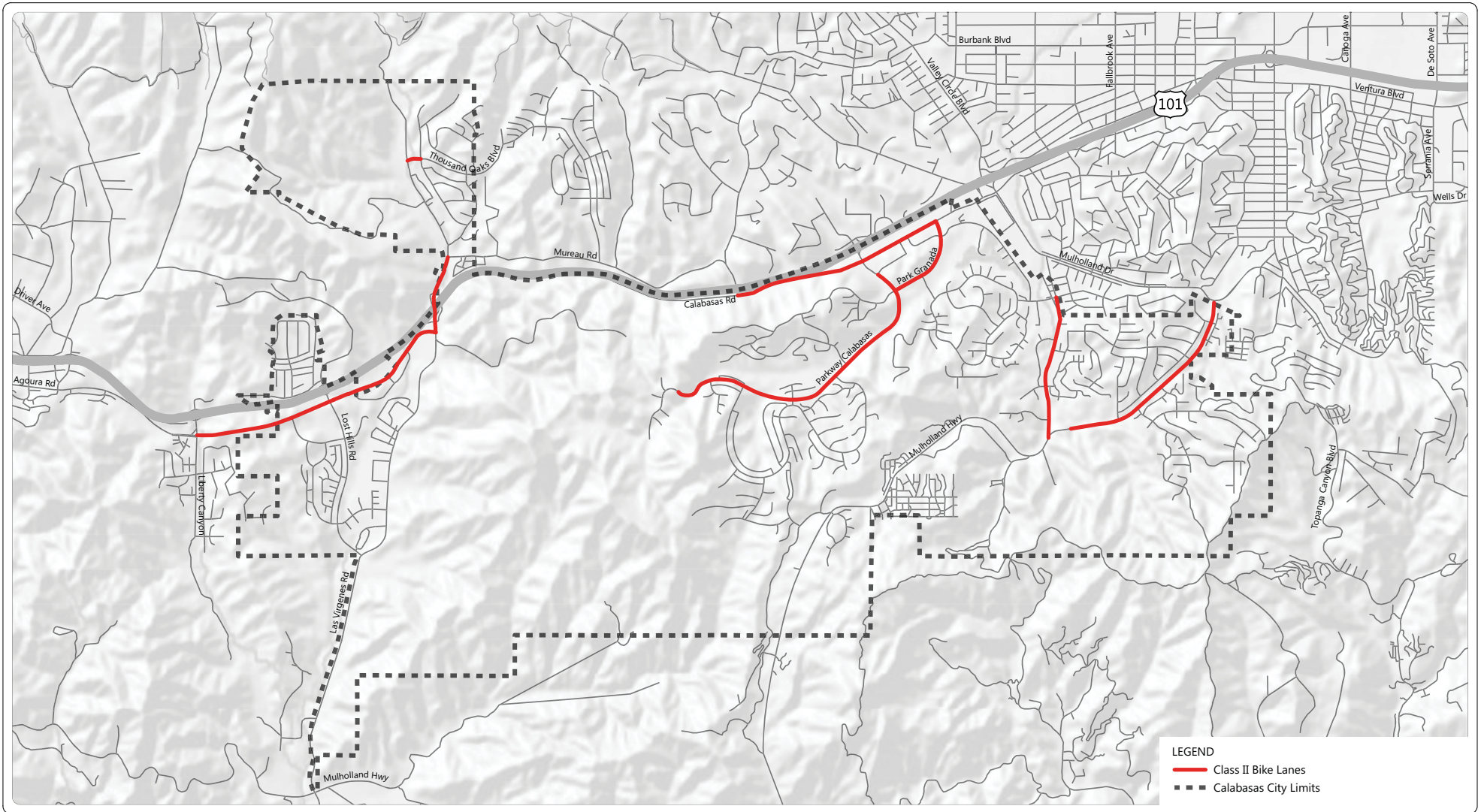

Not to Scale

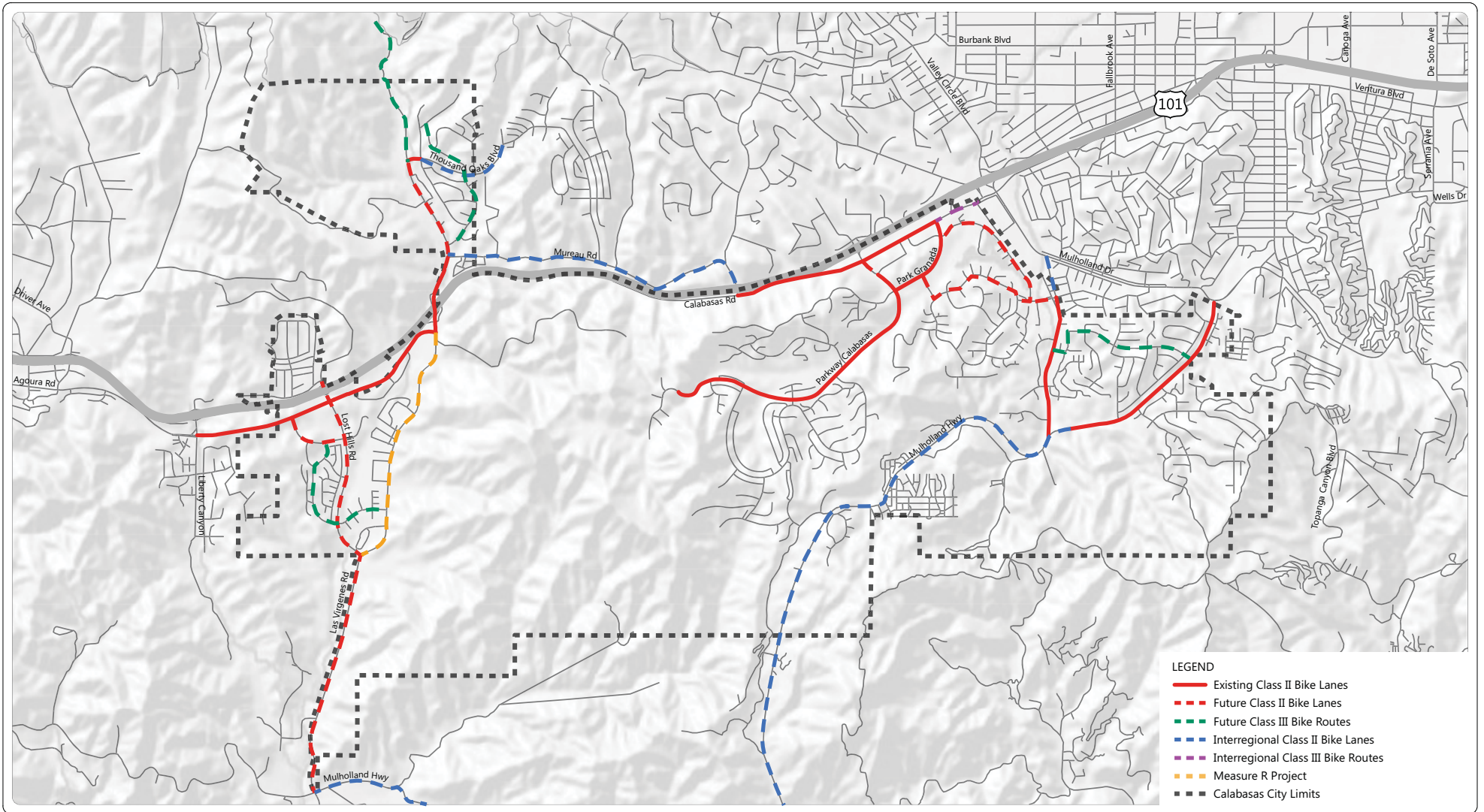

Not to Scale

APPENDIX G

**LEVEL OF SERVICE
ICU & HCM
WORKSHEETS**



RONDEL OASIS HOTEL
ICU CALCULATIONS

INTERSECTION 1: Las Virgenes Rd & Mureau Rd
EXISTING CONDITION (2014)

MOVEMENT	NO. OF LANES	CAPACITY	AM PEAK HOUR			PM PEAK HOUR			CRITICAL PAIR
			Traffic VOLUMES	V/C	*	Traffic VOLUMES	V/C	*	
NB LEFT	0	0	1	0.000	*	0	0.000		
NB THRU	2	3,200	540	0.169		549	0.172		
NB RIGHT	1	1,600	213	0.133		586	0.366	*	
								0.270	
SB LEFT	1	1,600	75	0.047		75	0.047	*	
SB THRU	2	3,200	864	0.270	*	864	0.270		
SB RIGHT	0	0	0	0.000		0	0.000		

EB LEFT	0	0	0	0.000		0	0.000		
EB THRU	0	0	0	0.000	*	0	0.000	*	
EB RIGHT	0	0	0	0.000	*	0	0.000	*	
								0.136	
WB LEFT	1	1,600	217	0.136	*	204	0.128	*	
WB THRU	0	0	0	0.000		0	0.000		
WB RIGHT	1	1,600	30	0.019		50	0.031		

		<u>RTOR</u>	NORTH/SOUTH CRITICAL SUM		0.270	NORTH/SOUTH CRITICAL SUM		0.413	
	<u>am</u>	<u>pm</u>	EAST/WEST CRITICAL SUM		0.136	EAST/WEST CRITICAL SUM		0.128	
NB	0	0	CLEARANCE INTERVAL		0.100	CLEARANCE INTERVAL		0.100	
SB	0	0							
EB	0	0	INTERSECTION ICU VALUE		0.506	INTERSECTION ICU VALUE		0.641	
WB	0	0							
			AM INTERSECTION LOS		A	PM INTERSECTION LOS		B	



RONDEL OASIS HOTEL
ICU CALCULATIONS

INTERSECTION: Las Virgenes Rd & Mureau Rd
EXISTING + Project

MOVEMENT	NO. OF LANES		CAPACITY	EXISTING	Project	TOTAL	V/C	AM PEAK HOUR			PM PEAK HOUR		
	CRITICAL PAIR	EXISTING						Project	TOTAL	V/C	CRITICAL PAIR		
NB LEFT	0	0	1	0	1	0.000	*	0	0	0	0.000		
NB THRU	2	3,200	540	1	541	0.169		549	2	551	0.172		
NB RIGHT	1	1600	213	3	216	0.135		586	4	590	0.369	*	
								0.271				0.416	
SB LEFT	1	1,600	75	0	75	0.047		75	0	75	0.047	*	
SB THRU	2	3,200	864	2	866	0.271	*	864	2	866	0.271		
SB RIGHT	0	0	0	0	0	0.000		0	0	0	0.000		

EB LEFT	0	0	0	0	0	0.000		0	0	0	0.000		
EB THRU	0	0	0	0	0	0.000		0	0	0	0.000		
EB RIGHT	0	0	0	0	0	0.000		0	0	0	0.000		
								0.138				0.130	
WB LEFT	1	1,600	217	4	221	0.138	*	204	4	208	0.130	*	
WB THRU	0	0	0	0	0	0.000		0	0	0	0.000		
WB RIGHT	1	1,600	30	0	30	0.019		50	0	50	0.031		

	<u>RTOR</u>		NORTH/SOUTH CRITICAL SUM				0.271	NORTH/SOUTH CRITICAL SUM				0.416	
	<u>am</u>	<u>pm</u>	EAST/WEST CRITICAL SUM				0.138	EAST/WEST CRITICAL SUM				0.130	
NB	0	0	CLEARANCE INTERVAL				0.100	CLEARANCE INTERVAL				0.100	
SB	0	0											
EB	0	0	INTERSECTION ICU VALUE				0.509	INTERSECTION ICU VALUE				0.646	
WB	0	0											
	AM INTERSECTION LOS				A	PM INTERSECTION LOS				B			
	AM IMPACT				0.003	PM IMPACT				0.005			



RONDEL OASIS HOTEL
ICU CALCULATIONS

INTERSECTION:

Las Virgenes Rd & Mureau Rd
EXISTING +AMBIENT+ CUMULATIVE PROJECT + PROJECT
Future 2016 With Project

MOVEMENT	NO. OF LANES		EXISTING	AMBIENT RELATED PROJECT			TOTAL	AM PEAK HOUR CRITICAL			AMBIENT RELATED PROJECT			TOTAL	PM PEAK HOUR CRITICAL			
	LANES	CAPACITY		GROWTH	PROJECT	PROJECT		V/C	PAIR	EXISTING	GROWTH	PROJECT	V/C		PAIR			
NB LEFT	0	0	1	0	0	0	1	0.000	*		0	0	0	0	0	0.000		
NB THRU	2	3,200	540	11	25	1	577	0.181			549	11	24	2	586	0.183		
NB RIGHT	1	1600	213	4	6	3	226	0.141			586	12	7	4	609	0.381	*	
										0.278							0.441	
SB LEFT	1	1,600	75	2	3	0	80	0.050			75	2	19	0	96	0.060	*	
SB THRU	2	3,200	864	17	7	2	890	0.278	*		864	17	42	2	925	0.289		
SB RIGHT	0	0	0	0	0	0	0	0.000			0	0	0	0	0	0.000		



















EB LEFT	0	0	0	0	0	0	0	0.000			0	0	0	0	0	0.000		
EB THRU	0	0	0	0	0	0	0	0.000			0	0	0	0	0	0.000		
EB RIGHT	0	0	0	0	0	0	0	0.000			0	0	0	0	0	0.000		
										0.143							0.140	
WB LEFT	1	1,600	217	4	3	4	228	0.143	*		204	4	12	4	224	0.140	*	
WB THRU	0	0	0	0	0	0	0	0.000			0	0	0	0	0	0.000		
WB RIGHT	1	1,600	30	1	13	0	44	0.027			50	1	11	0	62	0.039		

	<u>RTOR</u>			NORTH/SOUTH CRITICAL SUM						0.278		NORTH/SOUTH CRITICAL SUM						0.441
	<u>am</u>	<u>pm</u>		EAST/WEST CRITICAL SUM						0.143		EAST/WEST CRITICAL SUM						0.140
NB	0	0		CLEARANCE INTERVAL						0.100		CLEARANCE INTERVAL						0.100
SB	0	0																
EB	0	0		INTERSECTION ICU VALUE						0.521		INTERSECTION ICU VALUE						0.681
WB	0	0																
				AM INTERSECTION LOS						A		PM INTERSECTION LOS						B
				AM IMPACT						0.003		PM IMPACT						0.005

HCM 2010 Signalized Intersection Summary

2: LAS VIRGENES ROAD & NB 101 ONRAMP/NB 101 FWY OFF RAMP





















12/3/2014

												
Movement	EBL	EBT	EBR	WBL	WBT	WBR	NBL	NBT	NBR	SBL	SBT	SBR
Lane Configurations												
Volume (veh/h)	0	0	0	974	0	264	167	499	0	0	645	446
Number				3	8	18	5	2	12	1	6	16
Initial Q (Qb), veh				0	0	0	0	0	0	0	0	0
Ped-Bike Adj(A_pbT)				1.00		1.00	1.00		1.00	1.00		1.00
Parking Bus, Adj				1.00	1.00	1.00	1.00	1.00	1.00	1.00	1.00	1.00
Adj Sat Flow, veh/h/ln				1863	1863	1863	1863	1863	0	0	1863	1863
Adj Flow Rate, veh/h				1059	0	287	182	542	0	0	701	485
Adj No. of Lanes				2	0	1	1	2	0	0	2	1
Peak Hour Factor				0.92	0.92	0.92	0.92	0.92	0.92	0.92	0.92	0.92
Percent Heavy Veh, %				2	2	2	2	2	0	0	2	2
Cap, veh/h				1297	0	579	226	1828	0	0	1169	523
Arrive On Green				0.37	0.00	0.37	0.13	0.52	0.00	0.00	0.33	0.33
Sat Flow, veh/h				3548	0	1583	1774	3632	0	0	3632	1583
Grp Volume(v), veh/h				1059	0	287	182	542	0	0	701	485
Grp Sat Flow(s),veh/h/ln				1774	0	1583	1774	1770	0	0	1770	1583
Q Serve(g_s), s				18.3	0.0	9.5	6.8	5.9	0.0	0.0	11.2	20.0
Cycle Q Clear(g_c), s				18.3	0.0	9.5	6.8	5.9	0.0	0.0	11.2	20.0
Prop In Lane				1.00		1.00	1.00		0.00	0.00		1.00
Lane Grp Cap(c), veh/h				1297	0	579	226	1828	0	0	1169	523
V/C Ratio(X)				0.82	0.00	0.50	0.81	0.30	0.00	0.00	0.60	0.93
Avail Cap(c_a), veh/h				1676	0	748	314	1828	0	0	1169	523
HCM Platoon Ratio				1.00	1.00	1.00	1.00	1.00	1.00	1.00	1.00	1.00
Upstream Filter(I)				1.00	0.00	1.00	1.00	1.00	0.00	0.00	1.00	1.00
Uniform Delay (d), s/veh				19.4	0.0	16.7	28.8	9.4	0.0	0.0	18.9	21.9
Incr Delay (d2), s/veh				2.5	0.0	0.7	10.2	0.4	0.0	0.0	2.3	24.9
Initial Q Delay(d3),s/veh				0.0	0.0	0.0	0.0	0.0	0.0	0.0	0.0	0.0
%ile BackOfQ(50%),veh/ln				9.3	0.0	4.3	3.9	3.0	0.0	0.0	5.8	12.4
LnGrp Delay(d),s/veh				22.0	0.0	17.3	38.9	9.8	0.0	0.0	21.2	46.8
LnGrp LOS				C		B	D	A			C	D
Approach Vol, veh/h					1346			724			1186	
Approach Delay, s/veh					21.0			17.1			31.7	
Approach LOS					C			B			C	
Timer	1	2	3	4	5	6	7	8				
Assigned Phs		2			5	6		8				
Phs Duration (G+Y+Rc), s		46.2			12.6	33.6		28.8				
Change Period (Y+Rc), s		4.0			4.0	4.0		4.0				
Max Green Setting (Gmax), s		35.0			12.0	19.0		32.0				
Max Q Clear Time (g_c+I1), s		7.9			8.8	22.0		20.3				
Green Ext Time (p_c), s		12.6			0.1	0.0		4.5				
Intersection Summary												
HCM 2010 Ctrl Delay				24.0								
HCM 2010 LOS				C								
Notes												
User approved volume balancing among the lanes for turning movement.												

HCM 2010 Signalized Intersection Summary

2: LAS VIRGENES ROAD & NB 101 ONRAMP/NB 101 FWY OFF RAMP





















12/3/2014

												
Movement	EBL	EBT	EBR	WBL	WBT	WBR	NBL	NBT	NBR	SBL	SBT	SBR
Lane Configurations												
Volume (veh/h)	0	0	0	986	0	264	175	503	0	0	651	446
Number				3	8	18	5	2	12	1	6	16
Initial Q (Qb), veh				0	0	0	0	0	0	0	0	0
Ped-Bike Adj(A_pbT)				1.00		1.00	1.00		1.00	1.00		1.00
Parking Bus, Adj				1.00	1.00	1.00	1.00	1.00	1.00	1.00	1.00	1.00
Adj Sat Flow, veh/h/ln				1863	1863	1863	1863	1863	0	0	1863	1863
Adj Flow Rate, veh/h				1072	0	287	190	547	0	0	708	485
Adj No. of Lanes				2	0	1	1	2	0	0	2	1
Peak Hour Factor				0.92	0.92	0.92	0.92	0.92	0.92	0.92	0.92	0.92
Percent Heavy Veh, %				2	2	2	2	2	0	0	2	2
Cap, veh/h				1292	0	576	232	1842	0	0	1173	525
Arrive On Green				0.36	0.00	0.36	0.13	0.52	0.00	0.00	0.33	0.33
Sat Flow, veh/h				3548	0	1583	1774	3632	0	0	3632	1583
Grp Volume(v), veh/h				1072	0	287	190	547	0	0	708	485
Grp Sat Flow(s),veh/h/ln				1774	0	1583	1774	1770	0	0	1770	1583
Q Serve(g_s), s				19.0	0.0	9.7	7.2	6.1	0.0	0.0	11.6	20.4
Cycle Q Clear(g_c), s				19.0	0.0	9.7	7.2	6.1	0.0	0.0	11.6	20.4
Prop In Lane				1.00		1.00	1.00		0.00	0.00		1.00
Lane Grp Cap(c), veh/h				1292	0	576	232	1842	0	0	1173	525
V/C Ratio(X)				0.83	0.00	0.50	0.82	0.30	0.00	0.00	0.60	0.92
Avail Cap(c_a), veh/h				1590	0	709	282	1842	0	0	1173	525
HCM Platoon Ratio				1.00	1.00	1.00	1.00	1.00	1.00	1.00	1.00	1.00
Upstream Filter(I)				1.00	0.00	1.00	1.00	1.00	0.00	0.00	1.00	1.00
Uniform Delay (d), s/veh				20.0	0.0	17.1	29.3	9.4	0.0	0.0	19.3	22.3
Incr Delay (d2), s/veh				3.2	0.0	0.7	14.4	0.4	0.0	0.0	2.3	24.3
Initial Q Delay(d3),s/veh				0.0	0.0	0.0	0.0	0.0	0.0	0.0	0.0	0.0
%ile BackOfQ(50%),veh/ln				9.8	0.0	4.3	4.5	3.1	0.0	0.0	6.0	12.4
LnGrp Delay(d),s/veh				23.2	0.0	17.8	43.7	9.8	0.0	0.0	21.6	46.6
LnGrp LOS				C		B	D	A			C	D
Approach Vol, veh/h					1359			737			1193	
Approach Delay, s/veh					22.1			18.6			31.8	
Approach LOS					C			B			C	
Timer	1	2	3	4	5	6	7	8				
Assigned Phs		2			5	6		8				
Phs Duration (G+Y+Rc), s		45.8			13.1	32.8		29.2				
Change Period (Y+Rc), s		4.0			4.0	4.0		4.0				
Max Green Setting (Gmax), s		36.0			11.0	21.0		31.0				
Max Q Clear Time (g_c+I1), s		8.1			9.2	22.4		21.0				
Green Ext Time (p_c), s		12.9			0.1	0.0		4.1				
Intersection Summary												
HCM 2010 Ctrl Delay				24.8								
HCM 2010 LOS				C								
Notes												
User approved volume balancing among the lanes for turning movement.												

HCM 2010 Signalized Intersection Summary

2: LAS VIRGENES ROAD & NB 101 ONRAMP/NB 101 FWY OFF RAMP



















12/3/2014

												
Movement	EBL	EBT	EBR	WBL	WBT	WBR	NBL	NBT	NBR	SBL	SBT	SBR
Lane Configurations												
Volume (veh/h)	0	0	0	1018	0	275	203	535	0	0	667	457
Number				3	8	18	5	2	12	1	6	16
Initial Q (Qb), veh				0	0	0	0	0	0	0	0	0
Ped-Bike Adj(A_pbT)				1.00		1.00	1.00		1.00	1.00		1.00
Parking Bus, Adj				1.00	1.00	1.00	1.00	1.00	1.00	1.00	1.00	1.00
Adj Sat Flow, veh/h/ln				1863	1863	1863	1863	1863	0	0	1863	1863
Adj Flow Rate, veh/h				1107	0	299	221	582	0	0	725	497
Adj No. of Lanes				2	0	1	1	2	0	0	2	1
Peak Hour Factor				0.92	0.92	0.92	0.92	0.92	0.92	0.92	0.92	0.92
Percent Heavy Veh, %				2	2	2	2	2	0	0	2	2
Cap, veh/h				1300	0	580	265	1844	0	0	1116	499
Arrive On Green				0.37	0.00	0.37	0.15	0.52	0.00	0.00	0.32	0.32
Sat Flow, veh/h				3548	0	1583	1774	3632	0	0	3632	1583
Grp Volume(v), veh/h				1107	0	299	221	582	0	0	725	497
Grp Sat Flow(s),veh/h/ln				1774	0	1583	1774	1770	0	0	1770	1583
Q Serve(g_s), s				20.4	0.0	10.5	8.6	6.7	0.0	0.0	12.5	22.3
Cycle Q Clear(g_c), s				20.4	0.0	10.5	8.6	6.7	0.0	0.0	12.5	22.3
Prop In Lane				1.00		1.00	1.00		0.00	0.00		1.00
Lane Grp Cap(c), veh/h				1300	0	580	265	1844	0	0	1116	499
V/C Ratio(X)				0.85	0.00	0.52	0.83	0.32	0.00	0.00	0.65	1.00
Avail Cap(c_a), veh/h				1499	0	669	325	1844	0	0	1116	499
HCM Platoon Ratio				1.00	1.00	1.00	1.00	1.00	1.00	1.00	1.00	1.00
Upstream Filter(I)				1.00	0.00	1.00	1.00	1.00	0.00	0.00	1.00	1.00
Uniform Delay (d), s/veh				20.7	0.0	17.6	29.4	9.8	0.0	0.0	20.9	24.3
Incr Delay (d2), s/veh				4.4	0.0	0.7	14.3	0.4	0.0	0.0	2.9	39.2
Initial Q Delay(d3),s/veh				0.0	0.0	0.0	0.0	0.0	0.0	0.0	0.0	0.0
%ile BackOfQ(50%),veh/ln				10.6	0.0	4.7	5.2	3.3	0.0	0.0	6.5	15.1
LnGrp Delay(d),s/veh				25.1	0.0	18.3	43.7	10.2	0.0	0.0	23.9	63.5
LnGrp LOS				C		B	D	B			C	E
Approach Vol, veh/h					1406			803			1222	
Approach Delay, s/veh					23.7			19.4			40.0	
Approach LOS					C			B			D	
Timer	1	2	3	4	5	6	7	8				
Assigned Phs		2			5	6		8				
Phs Duration (G+Y+Rc), s		45.0			14.6	30.4		30.0				
Change Period (Y+Rc), s		4.0			4.0	4.0		4.0				
Max Green Setting (Gmax), s		37.0			13.0	20.0		30.0				
Max Q Clear Time (g_c+I1), s		8.7			10.6	24.3		22.4				
Green Ext Time (p_c), s		13.6			0.1	0.0		3.6				
Intersection Summary												
HCM 2010 Ctrl Delay				28.5								
HCM 2010 LOS				C								
Notes												
User approved volume balancing among the lanes for turning movement.												

HCM 2010 Signalized Intersection Summary

2: LAS VIRGENES ROAD & NB 101 ONRAMP/NB 101 FWY OFF RAMP





















12/3/2014

												
Movement	EBL	EBT	EBR	WBL	WBT	WBR	NBL	NBT	NBR	SBL	SBT	SBR
Lane Configurations												
Volume (veh/h)	0	0	0	1030	0	275	211	539	0	0	673	457
Number				3	8	18	5	2	12	1	6	16
Initial Q (Qb), veh				0	0	0	0	0	0	0	0	0
Ped-Bike Adj(A_pbT)				1.00		1.00	1.00		1.00	1.00		1.00
Parking Bus, Adj				1.00	1.00	1.00	1.00	1.00	1.00	1.00	1.00	1.00
Adj Sat Flow, veh/h/ln				1863	1863	1863	1863	1863	0	0	1863	1863
Adj Flow Rate, veh/h				1120	0	299	229	586	0	0	732	497
Adj No. of Lanes				2	0	1	1	2	0	0	2	1
Peak Hour Factor				0.92	0.92	0.92	0.92	0.92	0.92	0.92	0.92	0.92
Percent Heavy Veh, %				2	2	2	2	2	0	0	2	2
Cap, veh/h				1309	0	584	273	1837	0	0	1094	489
Arrive On Green				0.37	0.00	0.37	0.15	0.52	0.00	0.00	0.31	0.31
Sat Flow, veh/h				3548	0	1583	1774	3632	0	0	3632	1583
Grp Volume(v), veh/h				1120	0	299	229	586	0	0	732	497
Grp Sat Flow(s),veh/h/ln				1774	0	1583	1774	1770	0	0	1770	1583
Q Serve(g_s), s				20.8	0.0	10.5	8.9	6.8	0.0	0.0	12.8	22.0
Cycle Q Clear(g_c), s				20.8	0.0	10.5	8.9	6.8	0.0	0.0	12.8	22.0
Prop In Lane				1.00		1.00	1.00		0.00	0.00		1.00
Lane Grp Cap(c), veh/h				1309	0	584	273	1837	0	0	1094	489
V/C Ratio(X)				0.86	0.00	0.51	0.84	0.32	0.00	0.00	0.67	1.02
Avail Cap(c_a), veh/h				1493	0	666	323	1837	0	0	1094	489
HCM Platoon Ratio				1.00	1.00	1.00	1.00	1.00	1.00	1.00	1.00	1.00
Upstream Filter(I)				1.00	0.00	1.00	1.00	1.00	0.00	0.00	1.00	1.00
Uniform Delay (d), s/veh				20.8	0.0	17.5	29.3	9.9	0.0	0.0	21.5	24.6
Incr Delay (d2), s/veh				4.6	0.0	0.7	15.4	0.5	0.0	0.0	3.3	44.6
Initial Q Delay(d3),s/veh				0.0	0.0	0.0	0.0	0.0	0.0	0.0	0.0	0.0
%ile BackOfQ(50%),veh/ln				11.0	0.0	4.7	5.6	3.4	0.0	0.0	6.7	15.6
LnGrp Delay(d),s/veh				25.4	0.0	18.2	44.7	10.3	0.0	0.0	24.7	69.2
LnGrp LOS				C		B	D	B			C	F
Approach Vol, veh/h					1419			815			1229	
Approach Delay, s/veh					23.9			20.0			42.7	
Approach LOS					C			C			D	
Timer	1	2	3	4	5	6	7	8				
Assigned Phs		2			5	6		8				
Phs Duration (G+Y+Rc), s		44.7			15.0	29.7		30.3				
Change Period (Y+Rc), s		4.0			4.0	4.0		4.0				
Max Green Setting (Gmax), s		37.0			13.0	20.0		30.0				
Max Q Clear Time (g_c+I1), s		8.8			10.9	24.0		22.8				
Green Ext Time (p_c), s		13.7			0.1	0.0		3.5				
Intersection Summary												
HCM 2010 Ctrl Delay				29.7								
HCM 2010 LOS				C								
Notes												
User approved volume balancing among the lanes for turning movement.												

HCM 2010 Signalized Intersection Summary

2: LAS VIRGENES ROAD & NB 101 ONRAMP/NB 101 FWY OFF RAMP



















12/3/2014

												
Movement	EBL	EBT	EBR	WBL	WBT	WBR	NBL	NBT	NBR	SBL	SBT	SBR
Lane Configurations												
Volume (veh/h)	0	0	0	453	4	200	264	966	0	0	267	279
Number				3	8	18	5	2	12	1	6	16
Initial Q (Qb), veh				0	0	0	0	0	0	0	0	0
Ped-Bike Adj(A_pbT)				1.00		1.00	1.00		1.00	1.00		1.00
Parking Bus, Adj				1.00	1.00	1.00	1.00	1.00	1.00	1.00	1.00	1.00
Adj Sat Flow, veh/h/ln				1863	1863	1863	1863	1863	0	0	1863	1863
Adj Flow Rate, veh/h				495	0	217	287	1050	0	0	290	303
Adj No. of Lanes				2	0	1	1	2	0	0	2	1
Peak Hour Factor				0.92	0.92	0.92	0.92	0.92	0.92	0.92	0.92	0.92
Percent Heavy Veh, %				2	2	2	2	2	0	0	2	2
Cap, veh/h				653	0	291	335	2548	0	0	1710	765
Arrive On Green				0.18	0.00	0.18	0.19	0.72	0.00	0.00	0.48	0.48
Sat Flow, veh/h				3548	0	1583	1774	3632	0	0	3632	1583
Grp Volume(v), veh/h				495	0	217	287	1050	0	0	290	303
Grp Sat Flow(s),veh/h/ln				1774	0	1583	1774	1770	0	0	1770	1583
Q Serve(g_s), s				11.0	0.0	10.8	13.0	9.8	0.0	0.0	3.8	10.2
Cycle Q Clear(g_c), s				11.0	0.0	10.8	13.0	9.8	0.0	0.0	3.8	10.2
Prop In Lane				1.00		1.00	1.00		0.00	0.00		1.00
Lane Grp Cap(c), veh/h				653	0	291	335	2548	0	0	1710	765
V/C Ratio(X)				0.76	0.00	0.74	0.86	0.41	0.00	0.00	0.17	0.40
Avail Cap(c_a), veh/h				1150	0	513	617	2548	0	0	1710	765
HCM Platoon Ratio				1.00	1.00	1.00	1.00	1.00	1.00	1.00	1.00	1.00
Upstream Filter(I)				1.00	0.00	1.00	1.00	1.00	0.00	0.00	1.00	1.00
Uniform Delay (d), s/veh				32.2	0.0	32.2	32.7	4.6	0.0	0.0	12.1	13.8
Incr Delay (d2), s/veh				1.8	0.0	3.8	6.3	0.5	0.0	0.0	0.2	1.5
Initial Q Delay(d3),s/veh				0.0	0.0	0.0	0.0	0.0	0.0	0.0	0.0	0.0
%ile BackOfQ(50%),veh/ln				5.5	0.0	5.0	7.0	4.8	0.0	0.0	1.9	4.8
LnGrp Delay(d),s/veh				34.1	0.0	35.9	39.0	5.1	0.0	0.0	12.3	15.3
LnGrp LOS				C		D	D	A			B	B
Approach Vol, veh/h					712			1337			593	
Approach Delay, s/veh					34.6			12.4			13.9	
Approach LOS					C			B			B	
Timer	1	2	3	4	5	6	7	8				
Assigned Phs		2			5	6		8				
Phs Duration (G+Y+Rc), s		75.7			19.7	55.9		19.3				
Change Period (Y+Rc), s		4.0			4.0	4.0		4.0				
Max Green Setting (Gmax), s		60.0			29.0	27.0		27.0				
Max Q Clear Time (g_c+I1), s		11.8			15.0	12.2		13.0				
Green Ext Time (p_c), s		15.8			0.7	9.0		2.3				
Intersection Summary												
HCM 2010 Ctrl Delay				18.7								
HCM 2010 LOS				B								
Notes												
User approved volume balancing among the lanes for turning movement.												

HCM 2010 Signalized Intersection Summary

2: LAS VIRGENES ROAD & NB 101 ONRAMP/NB 101 FWY OFF RAMP



















12/3/2014

												
Movement	EBL	EBT	EBR	WBL	WBT	WBR	NBL	NBT	NBR	SBL	SBT	SBR
Lane Configurations												
Volume (veh/h)	0	0	0	465	4	200	275	972	0	0	273	279
Number				3	8	18	5	2	12	1	6	16
Initial Q (Qb), veh				0	0	0	0	0	0	0	0	0
Ped-Bike Adj(A_pbT)				1.00		1.00	1.00		1.00	1.00		1.00
Parking Bus, Adj				1.00	1.00	1.00	1.00	1.00	1.00	1.00	1.00	1.00
Adj Sat Flow, veh/h/ln				1863	1863	1863	1863	1863	0	0	1863	1863
Adj Flow Rate, veh/h				508	0	217	299	1057	0	0	297	303
Adj No. of Lanes				2	0	1	1	2	0	0	2	1
Peak Hour Factor				0.92	0.92	0.92	0.92	0.92	0.92	0.92	0.92	0.92
Percent Heavy Veh, %				2	2	2	2	2	0	0	2	2
Cap, veh/h				670	0	299	348	2528	0	0	1662	744
Arrive On Green				0.19	0.00	0.19	0.20	0.71	0.00	0.00	0.47	0.47
Sat Flow, veh/h				3548	0	1583	1774	3632	0	0	3632	1583
Grp Volume(v), veh/h				508	0	217	299	1057	0	0	297	303
Grp Sat Flow(s),veh/h/ln				1774	0	1583	1774	1770	0	0	1770	1583
Q Serve(g_s), s				11.2	0.0	10.6	13.5	10.0	0.0	0.0	4.0	10.4
Cycle Q Clear(g_c), s				11.2	0.0	10.6	13.5	10.0	0.0	0.0	4.0	10.4
Prop In Lane				1.00		1.00	1.00		0.00	0.00		1.00
Lane Grp Cap(c), veh/h				670	0	299	348	2528	0	0	1662	744
V/C Ratio(X)				0.76	0.00	0.73	0.86	0.42	0.00	0.00	0.18	0.41
Avail Cap(c_a), veh/h				1203	0	537	644	2528	0	0	1662	744
HCM Platoon Ratio				1.00	1.00	1.00	1.00	1.00	1.00	1.00	1.00	1.00
Upstream Filter(I)				1.00	0.00	1.00	1.00	1.00	0.00	0.00	1.00	1.00
Uniform Delay (d), s/veh				31.7	0.0	31.5	32.1	4.8	0.0	0.0	12.7	14.4
Incr Delay (d2), s/veh				1.8	0.0	3.4	6.2	0.5	0.0	0.0	0.2	1.7
Initial Q Delay(d3),s/veh				0.0	0.0	0.0	0.0	0.0	0.0	0.0	0.0	0.0
%ile BackOfQ(50%),veh/ln				5.7	0.0	4.9	7.2	5.0	0.0	0.0	2.0	4.9
LnGrp Delay(d),s/veh				33.5	0.0	34.8	38.3	5.3	0.0	0.0	12.9	16.0
LnGrp LOS				C		C	D	A			B	B
Approach Vol, veh/h					725			1356			600	
Approach Delay, s/veh					33.9			12.6			14.5	
Approach LOS					C			B			B	
Timer	1	2	3	4	5	6	7	8				
Assigned Phs		2			5	6		8				
Phs Duration (G+Y+Rc), s		75.4			20.2	55.2		19.6				
Change Period (Y+Rc), s		4.0			4.0	4.0		4.0				
Max Green Setting (Gmax), s		59.0			30.0	25.0		28.0				
Max Q Clear Time (g_c+I1), s		12.0			15.5	12.4		13.2				
Green Ext Time (p_c), s		15.9			0.8	8.1		2.4				
Intersection Summary												
HCM 2010 Ctrl Delay				18.8								
HCM 2010 LOS				B								
Notes												
User approved volume balancing among the lanes for turning movement.												

HCM 2010 Signalized Intersection Summary

2: LAS VIRGENES ROAD & NB 101 ONRAMP/NB 101 FWY OFF RAMP





















12/3/2014

												
Movement	EBL	EBT	EBR	WBL	WBT	WBR	NBL	NBT	NBR	SBL	SBT	SBR
Lane Configurations												
Volume (veh/h)	0	0	0	513	4	209	294	1013	0	0	317	294
Number				3	8	18	5	2	12	1	6	16
Initial Q (Qb), veh				0	0	0	0	0	0	0	0	0
Ped-Bike Adj(A_pbT)				1.00		1.00	1.00		1.00	1.00		1.00
Parking Bus, Adj				1.00	1.00	1.00	1.00	1.00	1.00	1.00	1.00	1.00
Adj Sat Flow, veh/h/ln				1863	1863	1863	1863	1863	0	0	1863	1863
Adj Flow Rate, veh/h				561	0	227	320	1101	0	0	345	320
Adj No. of Lanes				2	0	1	1	2	0	0	2	1
Peak Hour Factor				0.92	0.92	0.92	0.92	0.92	0.92	0.92	0.92	0.92
Percent Heavy Veh, %				2	2	2	2	2	0	0	2	2
Cap, veh/h				728	0	325	369	2472	0	0	1565	700
Arrive On Green				0.21	0.00	0.21	0.21	0.70	0.00	0.00	0.44	0.44
Sat Flow, veh/h				3548	0	1583	1774	3632	0	0	3632	1583
Grp Volume(v), veh/h				561	0	227	320	1101	0	0	345	320
Grp Sat Flow(s),veh/h/ln				1774	0	1583	1774	1770	0	0	1770	1583
Q Serve(g_s), s				12.4	0.0	11.0	14.5	11.3	0.0	0.0	5.0	11.7
Cycle Q Clear(g_c), s				12.4	0.0	11.0	14.5	11.3	0.0	0.0	5.0	11.7
Prop In Lane				1.00		1.00	1.00		0.00	0.00		1.00
Lane Grp Cap(c), veh/h				728	0	325	369	2472	0	0	1565	700
V/C Ratio(X)				0.77	0.00	0.70	0.87	0.45	0.00	0.00	0.22	0.46
Avail Cap(c_a), veh/h				1239	0	553	662	2472	0	0	1565	700
HCM Platoon Ratio				1.00	1.00	1.00	1.00	1.00	1.00	1.00	1.00	1.00
Upstream Filter(I)				1.00	0.00	1.00	1.00	1.00	0.00	0.00	1.00	1.00
Uniform Delay (d), s/veh				31.2	0.0	30.6	31.8	5.5	0.0	0.0	14.3	16.2
Incr Delay (d2), s/veh				1.8	0.0	2.7	6.2	0.6	0.0	0.0	0.3	2.1
Initial Q Delay(d3),s/veh				0.0	0.0	0.0	0.0	0.0	0.0	0.0	0.0	0.0
%ile BackOfQ(50%),veh/ln				6.3	0.0	5.0	7.7	5.6	0.0	0.0	2.5	5.5
LnGrp Delay(d),s/veh				32.9	0.0	33.4	37.9	6.1	0.0	0.0	14.6	18.3
LnGrp LOS				C		C	D	A			B	B
Approach Vol, veh/h					788			1421			665	
Approach Delay, s/veh					33.0			13.2			16.4	
Approach LOS					C			B			B	
Timer	1	2	3	4	5	6	7	8				
Assigned Phs		2			5	6		8				
Phs Duration (G+Y+Rc), s		74.0			21.3	52.7		21.0				
Change Period (Y+Rc), s		4.0			4.0	4.0		4.0				
Max Green Setting (Gmax), s		58.0			31.0	23.0		29.0				
Max Q Clear Time (g_c+I1), s		13.3			16.5	13.7		14.4				
Green Ext Time (p_c), s		17.3			0.8	6.7		2.6				
Intersection Summary												
HCM 2010 Ctrl Delay				19.4								
HCM 2010 LOS				B								
Notes												
User approved volume balancing among the lanes for turning movement.												

HCM 2010 Signalized Intersection Summary





















2: LAS VIRGENES ROAD & NB 101 ONRAMP/NB 101 FWY OFF RAMP

12/3/2014

												
Movement	EBL	EBT	EBR	WBL	WBT	WBR	NBL	NBT	NBR	SBL	SBT	SBR
Lane Configurations												
Volume (veh/h)	0	0	0	525	4	209	305	1019	0	0	323	294
Number				3	8	18	5	2	12	1	6	16
Initial Q (Qb), veh				0	0	0	0	0	0	0	0	0
Ped-Bike Adj(A_pbT)				1.00		1.00	1.00		1.00	1.00		1.00
Parking Bus, Adj				1.00	1.00	1.00	1.00	1.00	1.00	1.00	1.00	1.00
Adj Sat Flow, veh/h/ln				1863	1863	1863	1863	1863	0	0	1863	1863
Adj Flow Rate, veh/h				574	0	227	332	1108	0	0	351	320
Adj No. of Lanes				2	0	1	1	2	0	0	2	1
Peak Hour Factor				0.92	0.92	0.92	0.92	0.92	0.92	0.92	0.92	0.92
Percent Heavy Veh, %				2	2	2	2	2	0	0	2	2
Cap, veh/h				740	0	330	381	2461	0	0	1531	685
Arrive On Green				0.21	0.00	0.21	0.21	0.70	0.00	0.00	0.43	0.43
Sat Flow, veh/h				3548	0	1583	1774	3632	0	0	3632	1583
Grp Volume(v), veh/h				574	0	227	332	1108	0	0	351	320
Grp Sat Flow(s),veh/h/ln				1774	0	1583	1774	1770	0	0	1770	1583
Q Serve(g_s), s				12.7	0.0	11.0	15.1	11.6	0.0	0.0	5.2	12.0
Cycle Q Clear(g_c), s				12.7	0.0	11.0	15.1	11.6	0.0	0.0	5.2	12.0
Prop In Lane				1.00		1.00	1.00		0.00	0.00		1.00
Lane Grp Cap(c), veh/h				740	0	330	381	2461	0	0	1531	685
V/C Ratio(X)				0.78	0.00	0.69	0.87	0.45	0.00	0.00	0.23	0.47
Avail Cap(c_a), veh/h				1234	0	551	659	2461	0	0	1531	685
HCM Platoon Ratio				1.00	1.00	1.00	1.00	1.00	1.00	1.00	1.00	1.00
Upstream Filter(I)				1.00	0.00	1.00	1.00	1.00	0.00	0.00	1.00	1.00
Uniform Delay (d), s/veh				31.2	0.0	30.5	31.6	5.6	0.0	0.0	14.9	16.8
Incr Delay (d2), s/veh				1.8	0.0	2.5	6.3	0.6	0.0	0.0	0.3	2.3
Initial Q Delay(d3),s/veh				0.0	0.0	0.0	0.0	0.0	0.0	0.0	0.0	0.0
%ile BackOfQ(50%),veh/ln				6.4	0.0	5.0	8.1	5.7	0.0	0.0	2.6	5.7
LnGrp Delay(d),s/veh				32.9	0.0	33.0	38.0	6.2	0.0	0.0	15.3	19.1
LnGrp LOS				C		C	D	A			B	B
Approach Vol, veh/h					801			1440			671	
Approach Delay, s/veh					33.0			13.5			17.1	
Approach LOS					C			B			B	
Timer	1	2	3	4	5	6	7	8				
Assigned Phs		2			5	6		8				
Phs Duration (G+Y+Rc), s		73.6			21.9	51.7		21.4				
Change Period (Y+Rc), s		4.0			4.0	4.0		4.0				
Max Green Setting (Gmax), s		58.0			31.0	23.0		29.0				
Max Q Clear Time (g_c+I1), s		13.6			17.1	14.0		14.7				
Green Ext Time (p_c), s		17.5			0.9	6.6		2.7				
Intersection Summary												
HCM 2010 Ctrl Delay				19.7								
HCM 2010 LOS				B								
Notes												
User approved volume balancing among the lanes for turning movement.												





















HCM 2010 Signalized Intersection Summary
 3: LAS VIRGENES ROAD & SB 101 RAMPS/RONDELL

12/3/2014

												
Movement	EBL	EBT	EBR	WBL	WBT	WBR	NBL	NBT	NBR	SBL	SBT	SBR
Lane Configurations												
Volume (veh/h)	208	5	303	8	0	44	0	736	1	25	1354	300
Number	7	4	14	3	8	18	5	2	12	1	6	16
Initial Q (Qb), veh	0	0	0	0	0	0	0	0	0	0	0	0
Ped-Bike Adj(A_pbT)	1.00		1.00	1.00		1.00	1.00		1.00	1.00		1.00
Parking Bus, Adj	1.00	1.00	1.00	1.00	1.00	1.00	1.00	1.00	1.00	1.00	1.00	1.00
Adj Sat Flow, veh/h/ln	1900	1863	1863	1900	1863	1900	0	1863	1863	1863	1863	1863
Adj Flow Rate, veh/h	226	5	329	9	0	48	0	800	1	27	1472	326
Adj No. of Lanes	0	1	1	0	1	0	0	2	1	1	2	1
Peak Hour Factor	0.92	0.92	0.92	0.92	0.92	0.92	0.92	0.92	0.92	0.92	0.92	0.92
Percent Heavy Veh, %	2	2	2	2	2	2	0	2	2	2	2	2
Cap, veh/h	460	8	399	0	0	399	0	2197	983	460	2197	983
Arrive On Green	0.25	0.25	0.25	0.00	0.00	0.25	0.00	0.62	0.62	0.62	0.62	0.62
Sat Flow, veh/h	1376	30	1583	0	0	1583	0	3632	1583	676	3539	1583
Grp Volume(v), veh/h	231	0	329	0	0	48	0	800	1	27	1472	326
Grp Sat Flow(s),veh/h/ln	1407	0	1583	0	0	1583	0	1770	1583	676	1770	1583
Q Serve(g_s), s	7.5	0.0	12.3	0.0	0.0	1.5	0.0	7.0	0.0	1.3	17.0	6.2
Cycle Q Clear(g_c), s	9.0	0.0	12.3	0.0	0.0	1.5	0.0	7.0	0.0	8.2	17.0	6.2
Prop In Lane	0.98		1.00	0.00		1.00	0.00		1.00	1.00		1.00
Lane Grp Cap(c), veh/h	468	0	399	0	0	399	0	2197	983	460	2197	983
V/C Ratio(X)	0.49	0.00	0.83	0.00	0.00	0.12	0.00	0.36	0.00	0.06	0.67	0.33
Avail Cap(c_a), veh/h	558	0	504	0	0	706	0	2197	983	460	2197	983
HCM Platoon Ratio	1.00	1.00	1.00	1.00	1.00	1.00	1.00	1.00	1.00	1.00	1.00	1.00
Upstream Filter(I)	1.00	0.00	1.00	0.00	0.00	1.00	0.00	1.00	1.00	1.00	1.00	1.00
Uniform Delay (d), s/veh	20.7	0.0	22.2	0.0	0.0	18.1	0.0	5.8	4.5	7.9	7.7	5.7
Incr Delay (d2), s/veh	0.8	0.0	8.7	0.0	0.0	0.1	0.0	0.5	0.0	0.2	1.6	0.9
Initial Q Delay(d3),s/veh	0.0	0.0	0.0	0.0	0.0	0.0	0.0	0.0	0.0	0.0	0.0	0.0
%ile BackOfQ(50%),veh/ln	3.6	0.0	6.4	0.0	0.0	0.7	0.0	3.5	0.0	0.3	8.7	2.9
LnGrp Delay(d),s/veh	21.6	0.0	30.9	0.0	0.0	18.3	0.0	6.3	4.5	8.1	9.4	6.6
LnGrp LOS	C		C			B		A	A	A	A	A
Approach Vol, veh/h		560			48			801			1825	
Approach Delay, s/veh		27.1			18.3			6.3			8.9	
Approach LOS		C			B			A			A	
Timer	1	2	3	4	5	6	7	8				
Assigned Phs		2	3	4		6		8				
Phs Duration (G+Y+Rc), s		55.2	0.0	19.8		55.2		19.8				
Change Period (Y+Rc), s		4.0	4.0	4.0		4.0		4.0				
Max Green Setting (Gmax), s		39.0	4.0	20.0		39.0		28.0				
Max Q Clear Time (g_c+I1), s		9.0	0.0	14.3		19.0		3.5				
Green Ext Time (p_c), s		23.2	0.0	1.5		16.7		2.9				
Intersection Summary												
HCM 2010 Ctrl Delay			11.5									
HCM 2010 LOS			B									





















HCM 2010 Signalized Intersection Summary
 3: LAS VIRGENES ROAD & SB 101 RAMPS/RONDELL

12/3/2014

												
Movement	EBL	EBT	EBR	WBL	WBT	WBR	NBL	NBT	NBR	SBL	SBT	SBR
Lane Configurations												
Volume (veh/h)	208	17	303	15	8	56	0	736	11	43	1354	300
Number	7	4	14	3	8	18	5	2	12	1	6	16
Initial Q (Qb), veh	0	0	0	0	0	0	0	0	0	0	0	0
Ped-Bike Adj(A_pbT)	1.00		1.00	1.00		1.00	1.00		1.00	1.00		1.00
Parking Bus, Adj	1.00	1.00	1.00	1.00	1.00	1.00	1.00	1.00	1.00	1.00	1.00	1.00
Adj Sat Flow, veh/h/ln	1900	1863	1863	1900	1863	1900	0	1863	1863	1863	1863	1863
Adj Flow Rate, veh/h	226	18	329	16	9	61	0	800	12	47	1472	326
Adj No. of Lanes	0	1	1	0	1	0	0	2	1	1	2	1
Peak Hour Factor	0.92	0.92	0.92	0.92	0.92	0.92	0.92	0.92	0.92	0.92	0.92	0.92
Percent Heavy Veh, %	2	2	2	2	2	2	0	2	2	2	2	2
Cap, veh/h	441	26	401	0	53	356	0	2193	981	455	2193	981
Arrive On Green	0.25	0.25	0.25	0.00	0.25	0.25	0.00	0.62	0.62	0.62	0.62	0.62
Sat Flow, veh/h	1305	104	1583	0	208	1407	0	3632	1583	669	3539	1583
Grp Volume(v), veh/h	244	0	329	0	0	70	0	800	12	47	1472	326
Grp Sat Flow(s),veh/h/ln	1409	0	1583	0	0	1614	0	1770	1583	669	1770	1583
Q Serve(g_s), s	7.4	0.0	12.3	0.0	0.0	2.1	0.0	7.0	0.2	2.3	17.0	6.2
Cycle Q Clear(g_c), s	9.5	0.0	12.3	0.0	0.0	2.1	0.0	7.0	0.2	9.3	17.0	6.2
Prop In Lane	0.93		1.00	0.00		0.87	0.00		1.00	1.00		1.00
Lane Grp Cap(c), veh/h	467	0	401	0	0	409	0	2193	981	455	2193	981
V/C Ratio(X)	0.52	0.00	0.82	0.00	0.00	0.17	0.00	0.36	0.01	0.10	0.67	0.33
Avail Cap(c_a), veh/h	554	0	503	0	0	718	0	2193	981	455	2193	981
HCM Platoon Ratio	1.00	1.00	1.00	1.00	1.00	1.00	1.00	1.00	1.00	1.00	1.00	1.00
Upstream Filter(I)	1.00	0.00	1.00	0.00	0.00	1.00	0.00	1.00	1.00	1.00	1.00	1.00
Uniform Delay (d), s/veh	20.9	0.0	22.2	0.0	0.0	18.3	0.0	5.9	4.6	8.2	7.8	5.7
Incr Delay (d2), s/veh	0.9	0.0	8.5	0.0	0.0	0.2	0.0	0.5	0.0	0.5	1.7	0.9
Initial Q Delay(d3),s/veh	0.0	0.0	0.0	0.0	0.0	0.0	0.0	0.0	0.0	0.0	0.0	0.0
%ile BackOfQ(50%),veh/ln	3.9	0.0	6.3	0.0	0.0	1.0	0.0	3.5	0.1	0.5	8.7	2.9
LnGrp Delay(d),s/veh	21.8	0.0	30.6	0.0	0.0	18.5	0.0	6.4	4.6	8.6	9.5	6.6
LnGrp LOS	C		C			B		A	A	A	A	A
Approach Vol, veh/h		573			70			812			1845	
Approach Delay, s/veh		26.9			18.5			6.3			8.9	
Approach LOS		C			B			A			A	
Timer	1	2	3	4	5	6	7	8				
Assigned Phs		2	3	4		6		8				
Phs Duration (G+Y+Rc), s		55.1	0.0	19.9		55.1		19.9				
Change Period (Y+Rc), s		4.0	4.0	4.0		4.0		4.0				
Max Green Setting (Gmax), s		39.0	4.0	20.0		39.0		28.0				
Max Q Clear Time (g_c+I1), s		9.0	0.0	14.3		19.0		4.1				
Green Ext Time (p_c), s		23.4	0.0	1.6		16.7		3.2				
Intersection Summary												
HCM 2010 Ctrl Delay			11.6									
HCM 2010 LOS			B									





















HCM 2010 Signalized Intersection Summary
 3: LAS VIRGENES ROAD & SB 101 RAMPS/RONDELL

12/3/2014

												
Movement	EBL	EBT	EBR	WBL	WBT	WBR	NBL	NBT	NBR	SBL	SBT	SBR
Lane Configurations												
Volume (veh/h)	218	5	326	8	0	45	0	849	1	26	1412	308
Number	7	4	14	3	8	18	5	2	12	1	6	16
Initial Q (Qb), veh	0	0	0	0	0	0	0	0	0	0	0	0
Ped-Bike Adj(A_pbT)	1.00		1.00	1.00		1.00	1.00		1.00	1.00		1.00
Parking Bus, Adj	1.00	1.00	1.00	1.00	1.00	1.00	1.00	1.00	1.00	1.00	1.00	1.00
Adj Sat Flow, veh/h/ln	1900	1863	1863	1900	1863	1900	0	1863	1863	1863	1863	1863
Adj Flow Rate, veh/h	237	5	354	9	0	49	0	923	1	28	1535	335
Adj No. of Lanes	0	1	1	0	1	0	0	2	1	1	2	1
Peak Hour Factor	0.92	0.92	0.92	0.92	0.92	0.92	0.92	0.92	0.92	0.92	0.92	0.92
Percent Heavy Veh, %	2	2	2	2	2	2	0	2	2	2	2	2
Cap, veh/h	467	8	411	0	0	411	0	2183	977	401	2183	977
Arrive On Green	0.26	0.26	0.26	0.00	0.00	0.26	0.00	0.62	0.62	0.62	0.62	0.62
Sat Flow, veh/h	1375	29	1583	0	0	1583	0	3632	1583	603	3539	1583
Grp Volume(v), veh/h	242	0	354	0	0	49	0	923	1	28	1535	335
Grp Sat Flow(s),veh/h/ln	1404	0	1583	0	0	1583	0	1770	1583	603	1770	1583
Q Serve(g_s), s	8.2	0.0	13.8	0.0	0.0	1.5	0.0	8.8	0.0	1.6	19.0	6.7
Cycle Q Clear(g_c), s	9.7	0.0	13.8	0.0	0.0	1.5	0.0	8.8	0.0	10.4	19.0	6.7
Prop In Lane	0.98		1.00	0.00		1.00	0.00		1.00	1.00		1.00
Lane Grp Cap(c), veh/h	475	0	411	0	0	411	0	2183	977	401	2183	977
V/C Ratio(X)	0.51	0.00	0.86	0.00	0.00	0.12	0.00	0.42	0.00	0.07	0.70	0.34
Avail Cap(c_a), veh/h	520	0	464	0	0	659	0	2183	977	401	2183	977
HCM Platoon Ratio	1.00	1.00	1.00	1.00	1.00	1.00	1.00	1.00	1.00	1.00	1.00	1.00
Upstream Filter(I)	1.00	0.00	1.00	0.00	0.00	1.00	0.00	1.00	1.00	1.00	1.00	1.00
Uniform Delay (d), s/veh	21.2	0.0	22.9	0.0	0.0	18.3	0.0	6.4	4.8	9.1	8.4	6.0
Incr Delay (d2), s/veh	0.8	0.0	13.9	0.0	0.0	0.1	0.0	0.6	0.0	0.3	1.9	1.0
Initial Q Delay(d3),s/veh	0.0	0.0	0.0	0.0	0.0	0.0	0.0	0.0	0.0	0.0	0.0	0.0
%ile BackOfQ(50%),veh/ln	3.9	0.0	7.6	0.0	0.0	0.7	0.0	4.4	0.0	0.3	9.8	3.1
LnGrp Delay(d),s/veh	22.0	0.0	36.8	0.0	0.0	18.5	0.0	7.0	4.8	9.5	10.3	7.0
LnGrp LOS	C		D			B		A	A	A	B	A
Approach Vol, veh/h		596			49			924			1898	
Approach Delay, s/veh		30.8			18.5			7.0			9.7	
Approach LOS		C			B			A			A	
Timer	1	2	3	4	5	6	7	8				
Assigned Phs		2	3	4		6		8				
Phs Duration (G+Y+Rc), s		54.2	0.0	20.8		54.2		20.8				
Change Period (Y+Rc), s		4.0	4.0	4.0		4.0		4.0				
Max Green Setting (Gmax), s		40.0	4.0	19.0		40.0		27.0				
Max Q Clear Time (g_c+I1), s		10.8	0.0	15.8		21.0		3.5				
Green Ext Time (p_c), s		24.1	0.0	1.0		16.6		3.1				
Intersection Summary												
HCM 2010 Ctrl Delay			12.8									
HCM 2010 LOS			B									

HCM 2010 Signalized Intersection Summary
 3: LAS VIRGENES ROAD & SB 101 RAMPS/RONDELL





















12/3/2014

												
Movement	EBL	EBT	EBR	WBL	WBT	WBR	NBL	NBT	NBR	SBL	SBT	SBR
Lane Configurations												
Volume (veh/h)	218	17	326	15	8	57	0	849	11	44	1412	308
Number	7	4	14	3	8	18	5	2	12	1	6	16
Initial Q (Qb), veh	0	0	0	0	0	0	0	0	0	0	0	0
Ped-Bike Adj(A_pbT)	1.00		1.00	1.00		1.00	1.00		1.00	1.00		1.00
Parking Bus, Adj	1.00	1.00	1.00	1.00	1.00	1.00	1.00	1.00	1.00	1.00	1.00	1.00
Adj Sat Flow, veh/h/ln	1900	1863	1863	1900	1863	1900	0	1863	1863	1863	1863	1863
Adj Flow Rate, veh/h	237	18	354	16	9	62	0	923	12	48	1535	335
Adj No. of Lanes	0	1	1	0	1	0	0	2	1	1	2	1
Peak Hour Factor	0.92	0.92	0.92	0.92	0.92	0.92	0.92	0.92	0.92	0.92	0.92	0.92
Percent Heavy Veh, %	2	2	2	2	2	2	0	2	2	2	2	2
Cap, veh/h	437	26	421	0	54	375	0	2206	987	392	2206	987
Arrive On Green	0.27	0.27	0.27	0.00	0.27	0.27	0.00	0.62	0.62	0.62	0.62	0.62
Sat Flow, veh/h	1283	97	1583	0	205	1409	0	3632	1583	596	3539	1583
Grp Volume(v), veh/h	255	0	354	0	0	71	0	923	12	48	1535	335
Grp Sat Flow(s),veh/h/ln	1380	0	1583	0	0	1614	0	1770	1583	596	1770	1583
Q Serve(g_s), s	9.4	0.0	15.3	0.0	0.0	2.4	0.0	9.6	0.2	3.2	20.8	7.3
Cycle Q Clear(g_c), s	11.8	0.0	15.3	0.0	0.0	2.4	0.0	9.6	0.2	12.8	20.8	7.3
Prop In Lane	0.93		1.00	0.00		0.87	0.00		1.00	1.00		1.00
Lane Grp Cap(c), veh/h	463	0	421	0	0	429	0	2206	987	392	2206	987
V/C Ratio(X)	0.55	0.00	0.84	0.00	0.00	0.17	0.00	0.42	0.01	0.12	0.70	0.34
Avail Cap(c_a), veh/h	553	0	526	0	0	715	0	2206	987	392	2206	987
HCM Platoon Ratio	1.00	1.00	1.00	1.00	1.00	1.00	1.00	1.00	1.00	1.00	1.00	1.00
Upstream Filter(I)	1.00	0.00	1.00	0.00	0.00	1.00	0.00	1.00	1.00	1.00	1.00	1.00
Uniform Delay (d), s/veh	23.7	0.0	25.1	0.0	0.0	20.4	0.0	6.9	5.2	10.2	9.0	6.5
Incr Delay (d2), s/veh	1.0	0.0	9.7	0.0	0.0	0.2	0.0	0.6	0.0	0.6	1.8	0.9
Initial Q Delay(d3),s/veh	0.0	0.0	0.0	0.0	0.0	0.0	0.0	0.0	0.0	0.0	0.0	0.0
%ile BackOfQ(50%),veh/ln	4.7	0.0	7.8	0.0	0.0	1.1	0.0	4.8	0.1	0.6	10.6	3.4
LnGrp Delay(d),s/veh	24.7	0.0	34.7	0.0	0.0	20.5	0.0	7.5	5.2	10.8	10.9	7.4
LnGrp LOS	C		C			C		A	A	B	B	A
Approach Vol, veh/h		609			71			935			1918	
Approach Delay, s/veh		30.5			20.5			7.5			10.3	
Approach LOS		C			C			A			B	
Timer	1	2	3	4	5	6	7	8				
Assigned Phs		2	3	4		6		8				
Phs Duration (G+Y+Rc), s		61.8	0.0	23.2		61.8		23.2				
Change Period (Y+Rc), s		4.0	4.0	4.0		4.0		4.0				
Max Green Setting (Gmax), s		45.0	4.0	24.0		45.0		32.0				
Max Q Clear Time (g_c+I1), s		11.6	0.0	17.3		22.8		4.4				
Green Ext Time (p_c), s		27.1	0.0	1.9		19.1		3.5				
Intersection Summary												
HCM 2010 Ctrl Delay			13.2									
HCM 2010 LOS			B									

HCM 2010 Signalized Intersection Summary





















3: LAS VIRGENES ROAD & SB 101 RAMPS/RONDELL

12/3/2014

												
Movement	EBL	EBT	EBR	WBL	WBT	WBR	NBL	NBT	NBR	SBL	SBT	SBR
Lane Configurations												
Volume (veh/h)	470	1	134	13	0	33	0	1369	1	43	628	122
Number	7	4	14	3	8	18	5	2	12	1	6	16
Initial Q (Qb), veh	0	0	0	0	0	0	0	0	0	0	0	0
Ped-Bike Adj(A_pbT)	1.00		1.00	1.00		1.00	1.00		1.00	1.00		1.00
Parking Bus, Adj	1.00	1.00	1.00	1.00	1.00	1.00	1.00	1.00	1.00	1.00	1.00	1.00
Adj Sat Flow, veh/h/ln	1900	1863	1863	1900	1863	1900	0	1863	1863	1863	1863	1863
Adj Flow Rate, veh/h	511	1	146	14	0	36	0	1488	1	47	683	133
Adj No. of Lanes	0	1	1	0	1	0	0	2	1	1	2	1
Peak Hour Factor	0.92	0.92	0.92	0.92	0.92	0.92	0.92	0.92	0.92	0.92	0.92	0.92
Percent Heavy Veh, %	2	2	2	2	2	2	0	2	2	2	2	2
Cap, veh/h	645	1	639	0	0	639	0	1767	791	136	1767	791
Arrive On Green	0.40	0.40	0.40	0.00	0.00	0.40	0.00	0.50	0.50	0.50	0.50	0.50
Sat Flow, veh/h	1382	3	1583	0	0	1583	0	3632	1583	352	3539	1583
Grp Volume(v), veh/h	512	0	146	0	0	36	0	1488	1	47	683	133
Grp Sat Flow(s),veh/h/ln	1384	0	1583	0	0	1583	0	1770	1583	352	1770	1583
Q Serve(g_s), s	27.5	0.0	5.0	0.0	0.0	1.1	0.0	29.8	0.0	10.9	9.8	3.8
Cycle Q Clear(g_c), s	28.7	0.0	5.0	0.0	0.0	1.1	0.0	29.8	0.0	40.8	9.8	3.8
Prop In Lane	1.00		1.00	0.00		1.00	0.00		1.00	1.00		1.00
Lane Grp Cap(c), veh/h	646	0	639	0	0	639	0	1767	791	136	1767	791
V/C Ratio(X)	0.79	0.00	0.23	0.00	0.00	0.06	0.00	0.84	0.00	0.35	0.39	0.17
Avail Cap(c_a), veh/h	727	0	733	0	0	887	0	1767	791	136	1767	791
HCM Platoon Ratio	1.00	1.00	1.00	1.00	1.00	1.00	1.00	1.00	1.00	1.00	1.00	1.00
Upstream Filter(I)	1.00	0.00	1.00	0.00	0.00	1.00	0.00	1.00	1.00	1.00	1.00	1.00
Uniform Delay (d), s/veh	23.0	0.0	16.1	0.0	0.0	15.0	0.0	17.8	10.3	35.4	12.8	11.2
Incr Delay (d2), s/veh	5.4	0.0	0.2	0.0	0.0	0.0	0.0	5.1	0.0	6.9	0.6	0.5
Initial Q Delay(d3),s/veh	0.0	0.0	0.0	0.0	0.0	0.0	0.0	0.0	0.0	0.0	0.0	0.0
%ile BackOfQ(50%),veh/ln	11.9	0.0	2.2	0.0	0.0	0.5	0.0	15.7	0.0	1.3	4.9	1.7
LnGrp Delay(d),s/veh	28.4	0.0	16.3	0.0	0.0	15.0	0.0	22.8	10.3	42.2	13.4	11.7
LnGrp LOS	C		B			B		C	B	D	B	B
Approach Vol, veh/h		658			36			1489			863	
Approach Delay, s/veh		25.7			15.0			22.8			14.7	
Approach LOS		C			B			C			B	
Timer	1	2	3	4	5	6	7	8				
Assigned Phs		2	3	4		6		8				
Phs Duration (G+Y+Rc), s		57.9	0.0	37.1		57.9		37.1				
Change Period (Y+Rc), s		4.0	4.0	4.0		4.0		4.0				
Max Green Setting (Gmax), s		41.0	4.0	38.0		41.0		46.0				
Max Q Clear Time (g_c+I1), s		31.8	0.0	30.7		42.8		3.1				
Green Ext Time (p_c), s		8.1	0.0	2.4		0.0		4.7				
Intersection Summary												
HCM 2010 Ctrl Delay			21.1									
HCM 2010 LOS			C									





















HCM 2010 Signalized Intersection Summary
 3: LAS VIRGENES ROAD & SB 101 RAMPS/RONDELL

12/3/2014

												
Movement	EBL	EBT	EBR	WBL	WBT	WBR	NBL	NBT	NBR	SBL	SBT	SBR
Lane Configurations												
Volume (veh/h)	470	13	134	22	11	50	0	1369	11	60	628	122
Number	7	4	14	3	8	18	5	2	12	1	6	16
Initial Q (Qb), veh	0	0	0	0	0	0	0	0	0	0	0	0
Ped-Bike Adj(A_pbT)	1.00		1.00	1.00		1.00	1.00		1.00	1.00		1.00
Parking Bus, Adj	1.00	1.00	1.00	1.00	1.00	1.00	1.00	1.00	1.00	1.00	1.00	1.00
Adj Sat Flow, veh/h/ln	1900	1863	1863	1900	1863	1900	0	1863	1863	1863	1863	1863
Adj Flow Rate, veh/h	511	14	146	24	12	54	0	1488	12	65	683	133
Adj No. of Lanes	0	1	1	0	1	0	0	2	1	1	2	1
Peak Hour Factor	0.92	0.92	0.92	0.92	0.92	0.92	0.92	0.92	0.92	0.92	0.92	0.92
Percent Heavy Veh, %	2	2	2	2	2	2	0	2	2	2	2	2
Cap, veh/h	636	15	655	0	122	551	0	1737	777	128	1737	777
Arrive On Green	0.41	0.41	0.41	0.00	0.41	0.41	0.00	0.49	0.49	0.49	0.49	0.49
Sat Flow, veh/h	1332	36	1583	0	296	1332	0	3632	1583	348	3539	1583
Grp Volume(v), veh/h	525	0	146	0	0	66	0	1488	12	65	683	133
Grp Sat Flow(s),veh/h/ln	1368	0	1583	0	0	1628	0	1770	1583	348	1770	1583
Q Serve(g_s), s	28.3	0.0	5.0	0.0	0.0	2.1	0.0	30.9	0.3	10.1	10.2	3.9
Cycle Q Clear(g_c), s	30.4	0.0	5.0	0.0	0.0	2.1	0.0	30.9	0.3	41.0	10.2	3.9
Prop In Lane	0.97		1.00	0.00		0.82	0.00		1.00	1.00		1.00
Lane Grp Cap(c), veh/h	651	0	655	0	0	673	0	1737	777	128	1737	777
V/C Ratio(X)	0.81	0.00	0.22	0.00	0.00	0.10	0.00	0.86	0.02	0.51	0.39	0.17
Avail Cap(c_a), veh/h	706	0	720	0	0	896	0	1737	777	128	1737	777
HCM Platoon Ratio	1.00	1.00	1.00	1.00	1.00	1.00	1.00	1.00	1.00	1.00	1.00	1.00
Upstream Filter(I)	1.00	0.00	1.00	0.00	0.00	1.00	0.00	1.00	1.00	1.00	1.00	1.00
Uniform Delay (d), s/veh	23.0	0.0	15.8	0.0	0.0	15.0	0.0	18.7	10.9	38.5	13.4	11.8
Incr Delay (d2), s/veh	6.4	0.0	0.2	0.0	0.0	0.1	0.0	5.7	0.0	13.5	0.7	0.5
Initial Q Delay(d3),s/veh	0.0	0.0	0.0	0.0	0.0	0.0	0.0	0.0	0.0	0.0	0.0	0.0
%ile BackOfQ(50%),veh/ln	12.5	0.0	2.2	0.0	0.0	0.9	0.0	16.3	0.1	2.0	5.1	1.8
LnGrp Delay(d),s/veh	29.4	0.0	16.0	0.0	0.0	15.0	0.0	24.4	11.0	52.0	14.1	12.3
LnGrp LOS	C		B			B		C	B	D	B	B
Approach Vol, veh/h		671			66			1500			881	
Approach Delay, s/veh		26.5			15.0			24.3			16.6	
Approach LOS		C			B			C			B	
Timer	1	2	3	4	5	6	7	8				
Assigned Phs		2	3	4		6		8				
Phs Duration (G+Y+Rc), s		56.5	0.0	38.5		56.5		38.5				
Change Period (Y+Rc), s		4.0	4.0	4.0		4.0		4.0				
Max Green Setting (Gmax), s		41.0	4.0	38.0		41.0		46.0				
Max Q Clear Time (g_c+I1), s		32.9	0.0	32.4		43.0		4.1				
Green Ext Time (p_c), s		7.3	0.0	2.2		0.0		5.2				
Intersection Summary												
HCM 2010 Ctrl Delay			22.4									
HCM 2010 LOS			C									





















HCM 2010 Signalized Intersection Summary
 3: LAS VIRGENES ROAD & SB 101 RAMPS/RONDELL

12/3/2014

												
Movement	EBL	EBT	EBR	WBL	WBT	WBR	NBL	NBT	NBR	SBL	SBT	SBR
Lane Configurations												
Volume (veh/h)	484	1	174	13	0	34	0	1477	1	44	729	133
Number	7	4	14	3	8	18	5	2	12	1	6	16
Initial Q (Qb), veh	0	0	0	0	0	0	0	0	0	0	0	0
Ped-Bike Adj(A_pbT)	1.00		1.00	1.00		1.00	1.00		1.00	1.00		1.00
Parking Bus, Adj	1.00	1.00	1.00	1.00	1.00	1.00	1.00	1.00	1.00	1.00	1.00	1.00
Adj Sat Flow, veh/h/ln	1900	1863	1863	1900	1863	1900	0	1863	1863	1863	1863	1863
Adj Flow Rate, veh/h	526	1	189	14	0	37	0	1605	1	48	792	145
Adj No. of Lanes	0	1	1	0	1	0	0	2	1	1	2	1
Peak Hour Factor	0.92	0.92	0.92	0.92	0.92	0.92	0.92	0.92	0.92	0.92	0.92	0.92
Percent Heavy Veh, %	2	2	2	2	2	2	0	2	2	2	2	2
Cap, veh/h	648	1	646	0	0	646	0	1760	787	111	1760	787
Arrive On Green	0.41	0.41	0.41	0.00	0.00	0.41	0.00	0.50	0.50	0.50	0.50	0.50
Sat Flow, veh/h	1381	3	1583	0	0	1583	0	3632	1583	315	3539	1583
Grp Volume(v), veh/h	527	0	189	0	0	37	0	1605	1	48	792	145
Grp Sat Flow(s),veh/h/ln	1383	0	1583	0	0	1583	0	1770	1583	315	1770	1583
Q Serve(g_s), s	29.5	0.0	6.8	0.0	0.0	1.2	0.0	35.2	0.0	6.8	12.2	4.3
Cycle Q Clear(g_c), s	30.7	0.0	6.8	0.0	0.0	1.2	0.0	35.2	0.0	42.0	12.2	4.3
Prop In Lane	1.00		1.00	0.00		1.00	0.00		1.00	1.00		1.00
Lane Grp Cap(c), veh/h	649	0	646	0	0	646	0	1760	787	111	1760	787
V/C Ratio(X)	0.81	0.00	0.29	0.00	0.00	0.06	0.00	0.91	0.00	0.43	0.45	0.18
Avail Cap(c_a), veh/h	691	0	694	0	0	844	0	1760	787	111	1760	787
HCM Platoon Ratio	1.00	1.00	1.00	1.00	1.00	1.00	1.00	1.00	1.00	1.00	1.00	1.00
Upstream Filter(I)	1.00	0.00	1.00	0.00	0.00	1.00	0.00	1.00	1.00	1.00	1.00	1.00
Uniform Delay (d), s/veh	23.7	0.0	16.8	0.0	0.0	15.2	0.0	19.5	10.7	40.4	13.7	11.7
Incr Delay (d2), s/veh	6.9	0.0	0.2	0.0	0.0	0.0	0.0	8.7	0.0	11.9	0.8	0.5
Initial Q Delay(d3),s/veh	0.0	0.0	0.0	0.0	0.0	0.0	0.0	0.0	0.0	0.0	0.0	0.0
%ile BackOfQ(50%),veh/ln	13.0	0.0	3.0	0.0	0.0	0.5	0.0	19.1	0.0	1.5	6.1	2.0
LnGrp Delay(d),s/veh	30.6	0.0	17.1	0.0	0.0	15.2	0.0	28.2	10.7	52.4	14.6	12.3
LnGrp LOS	C		B			B		C	B	D	B	B
Approach Vol, veh/h		716			37			1606			985	
Approach Delay, s/veh		27.0			15.2			28.2			16.1	
Approach LOS		C			B			C			B	
Timer	1	2	3	4	5	6	7	8				
Assigned Phs		2	3	4		6		8				
Phs Duration (G+Y+Rc), s		56.6	0.0	38.4		56.6		38.4				
Change Period (Y+Rc), s		4.0	4.0	4.0		4.0		4.0				
Max Green Setting (Gmax), s		42.0	4.0	37.0		42.0		45.0				
Max Q Clear Time (g_c+I1), s		37.2	0.0	32.7		44.0		3.2				
Green Ext Time (p_c), s		4.5	0.0	1.8		0.0		5.1				
Intersection Summary												
HCM 2010 Ctrl Delay			24.2									
HCM 2010 LOS			C									

HCM 2010 Signalized Intersection Summary
 3: LAS VIRGENES ROAD & SB 101 RAMPS/RONDELL

12/3/2014

												
Movement	EBL	EBT	EBR	WBL	WBT	WBR	NBL	NBT	NBR	SBL	SBT	SBR
Lane Configurations												
Volume (veh/h)	484	13	174	22	11	51	0	1477	11	61	729	133
Number	7	4	14	3	8	18	5	2	12	1	6	16
Initial Q (Qb), veh	0	0	0	0	0	0	0	0	0	0	0	0
Ped-Bike Adj(A_pbT)	1.00		1.00	1.00		1.00	1.00		1.00	1.00		1.00
Parking Bus, Adj	1.00	1.00	1.00	1.00	1.00	1.00	1.00	1.00	1.00	1.00	1.00	1.00
Adj Sat Flow, veh/h/ln	1900	1863	1863	1900	1863	1900	0	1863	1863	1863	1863	1863
Adj Flow Rate, veh/h	526	14	189	24	12	55	0	1605	12	66	792	145
Adj No. of Lanes	0	1	1	0	1	0	0	2	1	1	2	1
Peak Hour Factor	0.92	0.92	0.92	0.92	0.92	0.92	0.92	0.92	0.92	0.92	0.92	0.92
Percent Heavy Veh, %	2	2	2	2	2	2	0	2	2	2	2	2
Cap, veh/h	637	15	660	0	122	557	0	1733	775	104	1733	775
Arrive On Green	0.42	0.42	0.42	0.00	0.42	0.42	0.00	0.49	0.49	0.49	0.49	0.49
Sat Flow, veh/h	1328	35	1583	0	291	1336	0	3632	1583	311	3539	1583
Grp Volume(v), veh/h	540	0	189	0	0	67	0	1605	12	66	792	145
Grp Sat Flow(s),veh/h/ln	1364	0	1583	0	0	1627	0	1770	1583	311	1770	1583
Q Serve(g_s), s	30.5	0.0	6.8	0.0	0.0	2.1	0.0	36.3	0.3	5.7	12.6	4.4
Cycle Q Clear(g_c), s	32.7	0.0	6.8	0.0	0.0	2.1	0.0	36.3	0.3	42.0	12.6	4.4
Prop In Lane	0.97		1.00	0.00		0.82	0.00		1.00	1.00		1.00
Lane Grp Cap(c), veh/h	652	0	660	0	0	679	0	1733	775	104	1733	775
V/C Ratio(X)	0.83	0.00	0.29	0.00	0.00	0.10	0.00	0.93	0.02	0.63	0.46	0.19
Avail Cap(c_a), veh/h	671	0	683	0	0	853	0	1733	775	104	1733	775
HCM Platoon Ratio	1.00	1.00	1.00	1.00	1.00	1.00	1.00	1.00	1.00	1.00	1.00	1.00
Upstream Filter(I)	1.00	0.00	1.00	0.00	0.00	1.00	0.00	1.00	1.00	1.00	1.00	1.00
Uniform Delay (d), s/veh	23.8	0.0	16.5	0.0	0.0	15.2	0.0	20.4	11.3	42.0	14.4	12.3
Incr Delay (d2), s/veh	8.4	0.0	0.2	0.0	0.0	0.1	0.0	10.0	0.0	25.6	0.9	0.5
Initial Q Delay(d3),s/veh	0.0	0.0	0.0	0.0	0.0	0.0	0.0	0.0	0.0	0.0	0.0	0.0
%ile BackOfQ(50%),veh/ln	13.7	0.0	3.0	0.0	0.0	1.0	0.0	20.0	0.2	2.3	6.4	2.0
LnGrp Delay(d),s/veh	32.2	0.0	16.8	0.0	0.0	15.3	0.0	30.5	11.3	67.6	15.3	12.8
LnGrp LOS	C		B			B		C	B	E	B	B
Approach Vol, veh/h		729			67			1617			1003	
Approach Delay, s/veh		28.2			15.3			30.3			18.4	
Approach LOS		C			B			C			B	
Timer	1	2	3	4	5	6	7	8				
Assigned Phs		2	3	4		6		8				
Phs Duration (G+Y+Rc), s		55.2	0.0	39.8		55.2		39.8				
Change Period (Y+Rc), s		4.0	4.0	4.0		4.0		4.0				
Max Green Setting (Gmax), s		42.0	4.0	37.0		42.0		45.0				
Max Q Clear Time (g_c+I1), s		38.3	0.0	34.7		44.0		4.1				
Green Ext Time (p_c), s		3.5	0.0	1.1		0.0		5.6				
Intersection Summary												
HCM 2010 Ctrl Delay			26.1									
HCM 2010 LOS			C									



RONDEL OASIS HOTEL
ICU CALCULATIONS

INTERSECTION: Lost Hills Road & Agoura Rd
EXISTING + Project

MOVEMENT	NO. OF		EXISTING	Project	TOTAL	AM PEAK HOUR			PM PEAK HOUR				
	LANES	CAPACITY				CRITICAL		CRITICAL	CRITICAL				
						PAIR	EXISTING		Project	TOTAL	V/C	PAIR	
NB LEFT	1	1,600	25	0	25	0.016	*	70	0	70	0.044		
NB THRU	2	3,200	451	0	451	0.160		533	0	533	0.185	*	
NB RIGHT	0	0	60	0	60	0.000		59	0	59	0.000		
								0.329				0.263	
SB LEFT	2	2,880	315	0	315	0.109		224	0	224	0.078	*	
SB THRU	2	3,200	769	0	769	0.313	*	400	0	400	0.137		
SB RIGHT	0	0	234	0	234	0.000		37	0	37	0.000		
EB LEFT	1	1,600	30	0	30	0.019		159	0	159	0.099	*	
EB THRU	2	3,200	100	4	104	0.040		238	4	242	0.093		
EB RIGHT	0	0	23	0	23	0.000		57	0	57	0.000		
								0.074				0.238	
WB LEFT	1	1,600	54	0	54	0.034	*	61	0	61	0.038		
WB THRU	2	3,200	117	3	120	0.038		190	4	194	0.061		
WB RIGHT	1	1,600	76	0	76	0.048		222	0	222	0.139	*	
RTOR						NORTH/SOUTH CRITICAL SUM			NORTH/SOUTH CRITICAL SUM			0.263	
am						EAST/WEST CRITICAL SUM			EAST/WEST CRITICAL SUM			0.238	
pm						CLEARANCE INTERVAL			CLEARANCE INTERVAL			0.100	
NB	0	0				INTERSECTION ICU VALUE			INTERSECTION ICU VALUE			0.601	
SB	0	0											
EB	0	0											
WB	0	0											
						AM INTERSECTION LOS			PM INTERSECTION LOS			B	
						AM IMPACT			PM IMPACT			0.000	

